

# **FlowCon** *international*

*A Griswold Controls LLC./FlowCon International Company*

*Pressure Independent Control, Temperature Control,  
Dynamic Balancing and  
Differential Pressure Regulation Valves*



## ISO CERTIFICATE 10

## PRESSURE INDEPENDENT CONTROL VALVES - BUILD-UP 11

### FlowCon UniQ® 15

- Pressure independent control valves (PICV)
- Adjustable to 41 different maximum flow rate limits for each control range
- Analog, 3-point floating or 2-position
- Standard feedback on electrical modulating actuator
- Optional failsafe
- Range of EuroCone end connections (according to EN215, Annex A) available or fixed end female-by-female threaded depending on body
- Sizes: 15-20mm (1/2"-3/4")
- Maximum flow rate range: 0.0056-0.2086 l/sec (0.089-3.305 GPM)

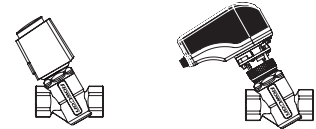

UniQ® with EV-actuator UniQ® with FN-actuator

## PRESSURE INDEPENDENT CONTROL VALVES - SERVICEABLE 23

### FlowCon Green (DN15-40) 27

- Pressure independent control valves (PICV)
- Adjustable to 41 different maximum flow rate limits for each control range
- Analog, 3-point floating or 2-position
- Standard feedback on electrical modulating actuator
- Optional failsafe
- Optional pressure/temperature plugs
- Range of union end connections available or fixed end female-by-female threaded depending on body
- Sizes: 15-40mm (1/2"-1 1/2")
- Maximum flow rate range: 0.0103-1.29 l/sec (0.163-20.4 GPM)

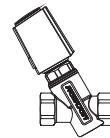

Green.0/1 with A and FT actuator

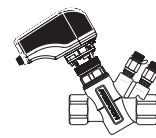

Green.0/1 with AB and FN actuator

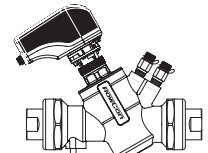

Green.2 with ABV2 and FN actuator

### FlowCon Green (DN40-50) 35

- Pressure independent control valves (PICV)
- Total authority
- Choice of actuator, electrical actuators: 24V 0(2)-10V modulating, 24V digital 2-position or 3-point-floating
- Adjustable to 41 different maximum flow rate limits
- Forged brass housing
- Optional pressure/temperature plugs
- Fixed female-by-female threaded
- Sizes: 40-50mm (1 1/2"-2")
- ΔP-range: 16-400 kPaD (2.3-58 psid)
- Flow rate: 0.528-3.79 l/sec (8.36-60.0 GPM)

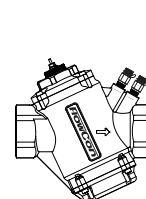

Green.3 without actuator

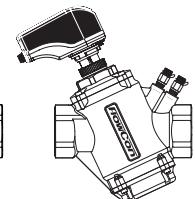

Green.3 with FH actuator

**FlowCon SM Valve, Union End Connections**

- Dynamic Self-balancing modulating control valve, total authority, pressure independent
- Adjustable to 51 different maximum flow rate limits for each size and control range
- Analog or 3-point floating
- Standard feedback
- Standard LED display of position; optional failsafe function
- External programming of all settings, interface with push-buttons and display
- Optional failsafe function
- Optional BACnet version
- Optional pressure/temperature plugs
- Range of union end connections available
- Sizes: 15-40mm (1/2"-1 1/2")
- Maximum flow rate range: 0.176-2.34 l/sec (2.79-37.1 GPM)

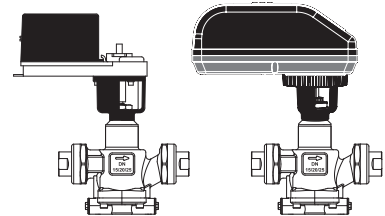

**FlowCon SM Wafer, Flange Connections**

- Dynamic Self-balancing modulating control valve, total authority, pressure independent
- Adjustable to 51 different maximum flow rate limits for each size and control range
- Analog, 3-point floating or 2-position
- Standard feedback
- External programming of all settings, interface with push-buttons and display
- Optional failsafe function
- Optional BACnet version
- Standard pressure/temperature plugs
- Flange connections
- Sizes: 50-150mm (2"-6")
- Maximum flow rate range: 1.48-29.5 l/sec (23.4-468 GPM)

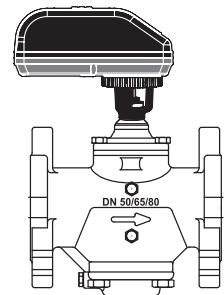

**FlowCon EVS**

- Dynamic balancing valve with temperature control
- Accessible stainless steel insert
- ON/OFF or analog control
- Optional pressure/temperature plugs
- Range of union end connections available or fixed end female-by-female threaded depending on body
- Sizes: 15-25mm (1/2"-1")
- Flow rate range: 0.0210-0.631 l/sec (0.333-10.0 GPM)

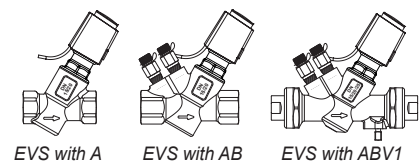

**FlowCon EVC 71**

- Dynamic balancing valve with temperature control
- Accessible, adjustable composite insert
- ON/OFF or analog control
- Optional pressure/temperature plugs
- Range of union end connections available on inlet; female threaded outlet
- Sizes: 15mm and 20mm (1/2" and 3/4")
- Flow rate range: 0.0081-0.408 l/sec (0.128-6.46 GPM)

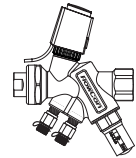

**FlowCon ABM 80**

- Electrically actuated two-way control valve with Optimizer® and dynamic balancing
- Accessible, adjustable composite insert
- Analog, 3-point floating or 2-position
- Optional pressure/temperature plugs
- Range of union end connections available
- Sizes: 15-40mm (1/2"-1 1/2")
- Flow rate range: 0.0081-1.62 l/sec (0.128-25.6 GPM)

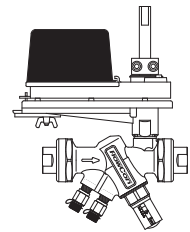

**TEMPERATURE CONTROL VALVES - 2-WAY AND 3-WAY 93**

**FlowCon Unimizer 2-way 93**

- Actuated control valves
- True equal percentage flow characteristics
- Patented Teflon seal for reduced torque allowing use of smaller actuator
- Blow out proof and field repairable stem
- Choice of actuators: 0(2)-10V modulating, 3-point floating or 2-position
- Choice of mounting kits for 3rd party actuators
- Choice of Kv-values for each valve size
- Sizes: 15-150mm (1/2"-6")
- ΔP-range: 15-80mm (1/2"-3"): 2400 kPaD (360 psid)  
100-150mm (4"-6"): 1600 kPaD (240 psid)

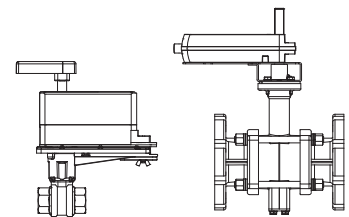

**FlowCon Unimizer 3-way 102**

- Actuated control valves
- True equal percentage flow characteristics
- Patented Teflon seal for reduced torque allowing use of smaller actuator
- Blow out proof and field repairable stem
- Choice of actuators: 0(2)-10V modulating, 3-point floating or 2-position
- Choice of mounting kits for 3rd party actuators
- Choice of Kv-values for each valve size
- Sizes: 15-150mm (1/2"-6")
- ΔP-range: 15-80mm (1/2"-3"): 2400 kPaD (360 psid)  
100-150mm (4"-6"): 1600 kPaD (240 psid)

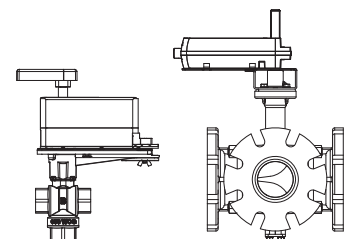

## ADJUSTABLE INSERT AUTOMATIC BALANCING VALVES

111

### FlowCon A

115

- Dynamic balancing valve
- Accessible, adjustable composite insert
- Female-by-female threaded
- Sizes: 15-25mm ISO (1/2" and 3/4" NPT)
- Flow rate range: 0.0081-0.408 l/sec (0.128-6.46 GPM)

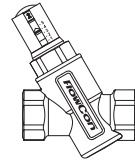

### FlowCon AB

123

- Dynamic balancing valve
- Accessible, adjustable composite insert
- Optional pressure/temperature plugs
- Female-by-female threaded
- Sizes: 15-50mm (1/2"-2")
- Flow rate range: 0.0081-4.48 l/s (0.128-70.9 GPM)

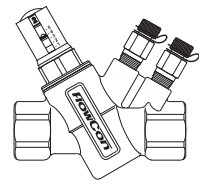

### FlowCon ABV

134

- Dynamic balancing valve with built-in isolation ball valve
- Accessible, adjustable composite insert
- Optional pressure/temperature plugs
- Range of union end connections available
- Sizes: 15-40mm (1/2"-1 1/2")
- Flow rate range: 0.0081-1.62 l/sec (0.128-25.6 GPM)

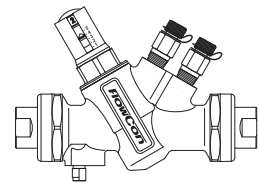

## EXTERNALLY ADJUSTABLE AUTOMATIC BALANCING VALVES

144

### FlowCon SH Valve, Union End Connections

148

- Externally adjustable dynamic balancing valve
- Adjustable to 51 different flow rate settings for each size and control range
- Optional pressure/temperature plugs
- Range of union end connections available
- Sizes: 15-40mm (1/2"-1 1/2")
- Flow rate range: 0.075-1.95 l/sec (1.2-30.9 GPM)

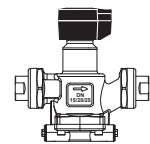

### FlowCon SH Wafer, Flange Connections

154

- Externally adjustable dynamic balancing valve
- Adjustable to 51 different flow rate settings for each size and control range
- Standard pressure/temperature plugs
- Flange connections
- Sizes: 50-150mm (2"-6")
- Maximum flow rate range: 1.48-29.5 l/sec (23.4-468 GPM)

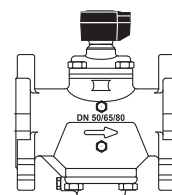

## PRE-SET AUTOMATIC BALANCING VALVES 15-80MM

162

### FlowCon K

166

- Dynamic balancing valve
- Accessible, removable pre-set stainless steel insert
- Optional pressure/temperature plugs
- Female-by-female threaded connection
- Sizes: 15-80mm (1/2"-3")
- Flow rate range: 0.021-10.1 l/sec (0.333-160 GPM)



### FlowCon Pure

178

- Dynamic balancing valve with pre-set built-in flow limiter
- AISI 316(L)
- For Tri-Clover connections
- Sizes: 40mm and 50mm (1 1/2" and 2"), clamp ferrules
- Flow rate range: 0.208-3.15 l/sec (3.3-49.8 GPM)

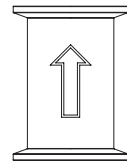

## PRE-SET AUTOMATIC BALANCING VALVES 50-1000MM

182

### FlowCon AHU Wafer

186

- Dynamic balancing valve
- Removable pre-set 3" stainless steel insert
- Standard pressure/temperature plugs
- For ANSI B 16.5 150 lb. or 300 lb. Class flanges
- Sizes: 50-80mm (2"-3")
- Flow rate range: 0.883-10.1 l/sec (14.0-160 GPM)

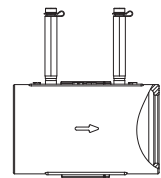

### FlowCon Wafer

190

- Dynamic balancing valve, multiple inserts
- Removable pre-set 3" stainless steel inserts
- Standard pressure/temperature plugs
- For ANSI B 16.5 150 lb. or 300 lb. Class flanges
- Sizes: 100-1000mm (4"-40")
- Flow rate range: 0.883-2286.9 l/sec (14.0-36250 GPM)

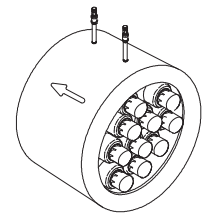

### FlowCon Uni-Flange

194

- Dynamic balancing valve, multiple inserts
- Accessible, removable pre-set 2" stainless steel insert(s)
- Standard pressure/temperature plugs
- For ANSI B 16.5 150 lb. Class flanges
- Size: 65/80mm (2 1/2" / 3")
- Flow rate range: 0.757-21.6 l/sec (12.0-342 GPM)

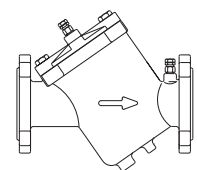

### FlowCon Grooved End

197

- Dynamic balancing valve, multiple inserts
- Removable pre-set 3" stainless steel insert(s)
- Standard pressure/temperature plugs
- Grooved end connection
- Sizes: 50-500mm (2"-20")
- Flow rate range: 0.883-642.6 l/sec (14.0-10185 GPM)

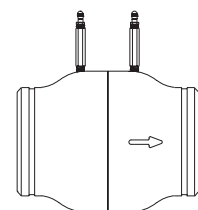

**FlowCon Green Inserts**

**217**

- Externally adjustable PICV insert, adjustable with a FlowCon key to one of 41 different flow rates
- $\Delta P$ -range: 16-400 kPaD (2.3-58 psid)
- Size: 20mm and 40mm (3/4" and 1 1/2")
- Flow rates: 0.0103-1.29 l/sec (0.163-20.4 GPM)

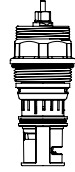

**FlowCon E-JUST Inserts**

**225**

- Externally adjustable composite insert, adjustable with a FlowCon key to one of 41 different flow rates
- $\Delta P$ -range: 17-400 kPaD (2.5-58 psid)
- Sizes: 20mm, 40mm and 50mm (3/4", 1 1/2" and 2")
- Flow rate: 0.0278-4.48 l/sec (0.440-70.9 GPM)



**FlowCon Composite Inserts**

**210**

- Internally adjustable composite insert, adjustable with an allen wrench to one of 8 different flow rates
- $\Delta P$ -range: 15-410 kPaD (2.2-59.5 psid)
- Sizes: 20mm and 40mm (3/4" and 1 1/2")
- Flow rate: 0.0081-1.43 l/sec (0.128-22.7 GPM)



**FlowCon Stainless Steel Inserts**

**212**

- Factory pre-set stainless steel insert, AISI 304
- $\Delta P$ -range: 10-880 kPaD (1-128 psid)
- Sizes: 20mm, 40mm, 50mm and 80mm (3/4", 1 1/2", 2" and 3")
- Flow rate: 0.0210-18.9 l/sec (0.333-300 GPM)



## DIFFERENTIAL PRESSURE CONTROL VALVES

233

### FlowCon SDP

233

- Pre-set differential pressure control valve
- No site adjustment
- Tamper proof
- Available in 3 pressure range; 10, 20 and 30 kPaD.
- 3 different valve bodies available
- Standard brass or DZR brass
- Sizes: 15/20/25mm (1/2" / 3/4" / 1") valves
- Operational  $\Delta P$  ( $\Delta P_v$ ): 3-400 kPaD (0.4-58 psid)
- Flow rate range: 45-1419 l/hr (0-6 GPM)

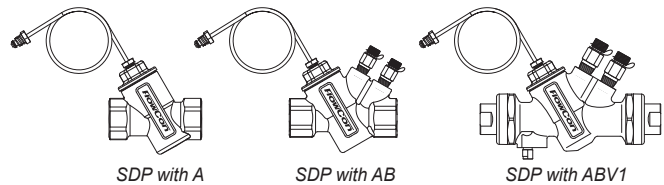

### FlowCon DPCV

239

- Differential pressure control valve
- Adjustable to 7 different controlled  $\Delta P$  settings for each size
- Optional pressure/temperature plugs
- ISO sizes: 15-50mm (1/2"-2")
- Controlled  $\Delta P$  rate: 5, 10, 15, 20, 25, 30 and 35 kPaD (0.7, 1.5, 2.2, 2.9, 3.6, 4.4 and 5.1 psid)

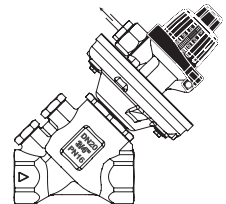

### FlowCon ADP

248

- Combined  $\Delta P$  controller, balancing and control valve
- Maximum differential pressure protection of the system
- 41 different flow settings
- 3 different valve bodies available
- Standard brass or DZR brass
- Sizes: 15/20/25mm (1/2" / 3/4" / 1") valves
- Maximum operational  $\Delta P$ : 400 kPaD (58 psid)
- Flow rate range: 9-680 l/hr (0.040-2.994 GPM)

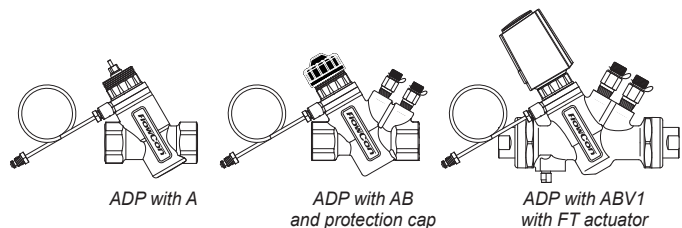

## THERMOSTATIC CONTROL VALVES

255

### FlowCon T-JUST

259

- Thermostatic control valve
- Fits in a range of FlowCon valve bodies
- Size: 20mm (3/4")
- Temperature range: +35°C to +65°C

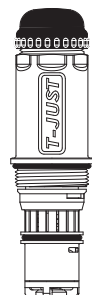

**FlowCon Mini By-Pass Unit**

263

- 3 way mini By-Pass unit
- Forged brass housing
- Nickel plated brass ball valves
- Can be fitted with optional valve bodies supply/return side (UniQ®, A, AB, ABV or EVC 15-25mm (1/2"-1"))
- Can be fitted with optional strainer and drain possibility on supply side.
- Can be fitted with optional inserts on return side (Green, EVS, Composite, E-JUST or Stainless Steel)
- Can be fitted with a range of optional actuators on return side (depending on insert selection and valve body)
- Optional side option for drain, air vent or p/t plugs
- ISO Sizes: 4 x 20mm (3/4") male fixed end for DN15 EuroCone  
Multiple union end connections available

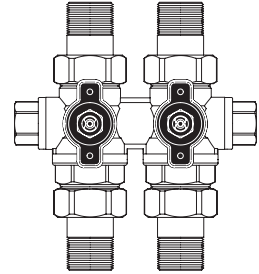
**FlowCon By-Pass Unit**

266

- 3 way By-Pass unit
- Forged brass housing
- Nickel plated brass ball valves
- Can be fitted with optional valve bodies supply/return side (UniQ®, A, AB, ABV, EVC or SM 15-40mm (1/2"-1 1/2"))
- Can be fitted with optional strainer and drain possibility on supply side.
- Can be fitted with optional inserts on return side (Green, EVS, Composite, E-JUST or Stainless Steel)
- Can be fitted with a range of optional actuators on return side (depending on insert selection and valve body)
- ISO Sizes: 2 x 15mm (1/2") male fixed end + 2 x union end conn. (1/2"-1")  
2 x 20mm (3/4") male fixed end + 2 x union end conn. (1/2"-1")  
4 x union end conn. 15/20/25mm (1/2" / 3/4" / 1")
- NPT Sizes: 4 x union end conn. 1/2" / 3/4" / 1"

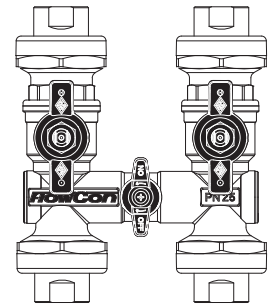
**FlowCon Strainer**

270

- Stainless steel strainer, mesh 60
- Optional pressure/temperature plugs (AB and ABS)
- Integral isolation ball valve (ABS)
- Range of union end connections available (ABS)
- Fixed female threaded ends (A and AB)
- Optional blow-down valve
- Sizes: 15-40mm (1/2"-1 1/2")

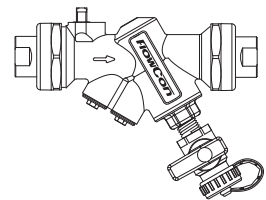
**FlowCon Commissioning Meter**

273

- Electronic manometer incl. data on all FlowCon valves
- Measurement range: 0.5-600 kPaD (0.07-87 psid)
- Range of accessories available incl. calculation software
- Selectable pressure units
- Selectable flow units

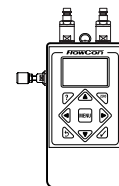
**FlowCon Insulation Shells**

277

- Fit FlowCon valve bodies A, AB, ABV, EVS, EVC and 4-union end bypass
- Fit FlowCon valve bodies with option of Green, E-JUST, Composite, Stainless Steel, Strainer or T-JUST
- Easy Soft Snap Function
- Separate access to p/t plugs (ACCIPT)
- Size: 15-25mm (1/2"-1")

For other accessory options, please see [www.flowcon.com](http://www.flowcon.com)

**BUREAU VERITAS**  
Certification



## Certification

Awarded to

**FlowCon International ApS**

*Trafikcenter Allé 17, 4200 Slagelse, Denmark*

Bureau Veritas Certification Denmark A/S certifies that the Management System of the above organisation has been audited and found to be in accordance with the requirements of the Management System standards detailed below.

STANDARD

**ISO 9001:2008**

SCOPE OF CERTIFICATION

**Development, sourcing, production, assembling, marketing  
and sales of Dynamic Flow and Temperature Control.**

*Original approval date:* 29-01-2007

*Certification cycle start date:* 23-01-2016

*Subject to the continued satisfactory operation of the organisation's Management System, this certificate is valid until:* 15-09-2018

*To check the validity of this certificate, please call: (+45) 77 311 000.*

*Further clarification regarding the scope of this certificate and the applicability of the system requirements may be obtained by consulting the organisation.*

*Certificate Number:* DK006027-1

*Date:* 05-01-2016

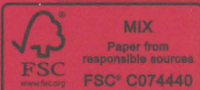

*Mikkel Høgger*

Certification Office: Bureau Veritas Certification Denmark A/S, Øjersborggade 1B, 7000 Fredericia, Denmark

 **DANAK**  
SYSTEM Reg nr. 5005

# FlowCon UniQ<sup>®</sup>



*Adjustable and Compact PICV - Simply UniQ<sup>®</sup>*

# FlowCon UniQ®

*Adjustable and Compact Pressure Independent Control Valve*

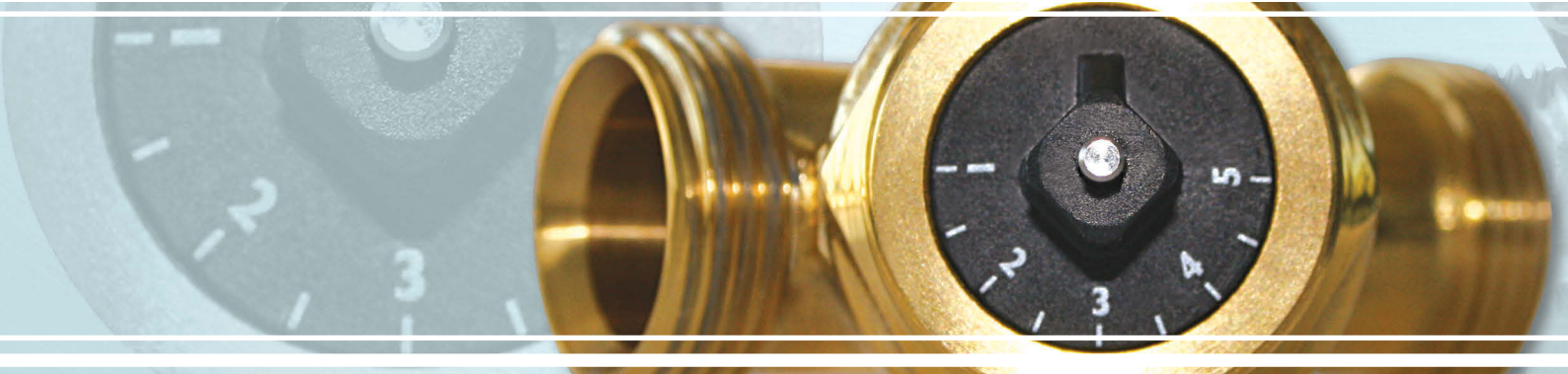

The innovative design of FlowCon UniQ® brings the PICV technology to the next level. FlowCon has now accomplished to make the PICV even more compact and is still able to deliver the same basic benefits as FlowCon's other adjustable PICVs offer. The Pressure Independent Control Valve (PICV) technology was brought to the market some twenty years ago by FlowCon's introduction of the first SM-valve. This technology has now matured and is widely accepted as a proven application for optimizing system  $\Delta T$ , enhancing system performance and reducing energy cost.

The compact design of FlowCon UniQ® provides a 3-in-1 complete unit covering flow rates from 20.3 to 751 l/hr in a  $\Delta P$  range of 10-200 kPaD. The valve offers stepless adjustment with 41 different setting indications between minimum and maximum. Further, this compact PICV will match most current FlowCon actuators providing options for thermal and electrical control.

The FlowCon UniQ® is PN25 rated and available in two versions being either fixed female-by-female (DN15 and DN20) or fixed ends suitable for DN15 EuroCone connections with a range of possible end connections. Body material is forged brass with composite internal parts and an EPDM diaphragm.

The FlowCon UniQ® has a minimum working pressure of only 10 kPaD, which allows even bigger energy savings than normally seen for PICV valves. In fact, FlowCon is the first to accomplish such low minimum working pressure.

## Applications

The FlowCon UniQ® can be ordered in following sizes :

- Fixed female: DN15 or DN20 ISO (1/2" and 3/4")
- 20mm male ISO suitable for DN15 EuroCone

***This valve is particular ideal for chilled ceilings, chilled beams or small FCUs. It can be used in both new installations as well as retrofit projects.***

## 100% Authority Pressure Independent

The FlowCon UniQ® is a 100% authority guaranteed pressure independent flow control valve with full stroke modulation. The Kv of the valve is constantly varying compensating for system pressure changes maintaining the selected flow constant. The PICV instantaneously self-balance at all points of operation, even when exposed to variable control signals providing optimal authority at all times. Even if the valve maximum flow is reduced by the scale setting the actuator will always use full stroke of the spindle offering electrical control over the full stroke length at all times.

## Features and Benefits

- A **compact one-unit PICV** (housing and regulator is combined).
- **Accuracy:** Greatest of either  $\pm 10\%$  of controlled flow or  $\pm 5\%$  of maximum flow rate.
- **No need of calculating** valve authority - 100% is provided guaranteed.
- **Up to 41 different and selectable flow settings** (20.3-751 l/hr) - stepless settings in between.
- A working pressure starting at only 10 kPaD resulting in **pump energy savings**.
- **Fast response time** to pressure fluctuations increasing system stability.
- **Low flow rates** making it ideal for low flow applications such as chilled ceilings etc.
- **Choice of actuator:** Thermal actuators: 0-10V modulation or ON/OFF. Electrical actuators: 0(2)-10V modulating, 3-point floating or 2-position.
- **Full stroke modulation.**
- **360° view of actuator and valve position.**
- The choice between either **fixed female-female** or **EuroCone** connections.
- **The most compact valve** in the FlowCon series PICV valve range.
- Real pressure independency at all flow rates and all actuator positions – **a true PICV**.
- A shorter starting time phase thanks to the dynamic regulation of the system and **reduced commissioning time**.



FlowCon UniQ®				Setting
15/20mm · 1/2" / 3/4"				
10 <sup>1</sup> -200 kPaD · 1.5 <sup>1</sup> -29 psid				
l/sec	l/hr	GPM		
0.0056	20.3	0.089	1.0	
0.0100	36.0	0.158	1.1	
0.0157	56.7	0.249	1.2	
0.0223	80.1	0.353	1.3	
0.0291	105	0.461	1.4	
0.0360	129	0.570	1.5	
0.0426	153	0.675	1.6	
0.0489	176	0.775	1.7	
0.0549	198	0.869	1.8	
0.0604	218	0.957	1.9	
0.0657	237	1.041	2.0	
0.0708	255	1.121	2.1	
0.0757	273	1.199	2.2	
0.0806	290	1.277	2.3	
0.0856	308	1.356	2.4	
0.0908	327	1.439	2.5	
0.0963	347	1.526	2.6	
0.1022	368	1.618	2.7	
0.1084	390	1.716	2.8	
0.1149	414	1.820	2.9	
0.1218	439	1.930	3.0	
0.1291	465	2.044	3.1	
0.1365	491	2.162	3.2	
0.1440	518	2.281	3.3	
0.1515	546	2.400	3.4	
0.1589	572	2.516	3.5	
0.1658	597	2.627	3.6	
0.1723	620	2.730	3.7	
0.1782	642	2.823	3.8	
0.1833	660	2.903	3.9	
0.1874	675	2.969	4.0	
0.1907	686	3.020	4.1	
0.1929	695	3.056	4.2	
0.1943	699	3.078	4.3	
0.1947	701	3.084	4.4	
0.1951	702	3.091	4.5	
0.1952	703	3.092	4.6	
0.1958	705	3.102	4.7	
0.1976	711	3.130	4.8	
0.2015	725	3.192	4.9	
0.2086	751	3.305	5.0	

Nominal flow rate

Accuracy: Greatest of either ±10% of controlled flow rate or ±5% of maximum flow rate.

Note 1: Min. ΔP=10 x √setting

### Principle of Operation

On closer examination of the inner working of the FlowCon UniQ®, the function is best described as 2 valves in 1. The second valve (V2) regulates the pressure differential across the first valve (V1) by means of a rolling diaphragm element counteracted by a spring. The first valve (V1) is a calibrated variable orifice device adjusted by the actuator (similar to a standard modulating control valve).

The diaphragm reacts to the system and regulates the pressure differential across the actuated control valve orifice to maintain its flow rate.

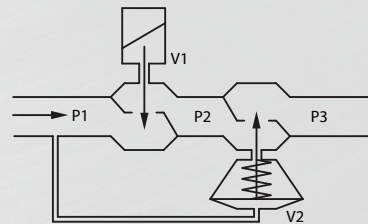

When pre-setting the maximum flow rate, the inlet orifice is changed in size sideways which does not interfere with the length of the stroke. When modulating, the orifice area is affected by the actuator which results in the fact that the orifice area is changed in size in a vertical movement.

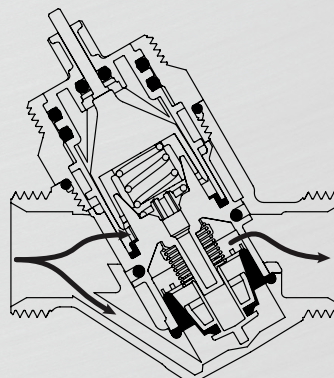

**Hydronic Balance**

The valve can be pre-set to limit the maximum flow through the valve. Consequently, hydronic balance is achieved automatically without the use of additional balancing valves.

Setting can be seen directly on the valve top indicated by a scale going from 1.0 to 5.0. Position is defined by a "dot" marked on the edge of the housing top.

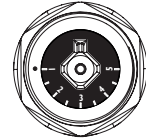

**Settings and operation**

Setting the FlowCon UniQ® is easy. Rough setting (9 stepless settings) is done with the standard FlowCon adjustment key. Fine tuning for a more exact setting (41 stepless settings) is done with an optional FlowCon adjustment wheel.

Setting is protected and made "tamper-proof" when placing the actuator on the valve.

For further information please see the installation and operation instruction manual.

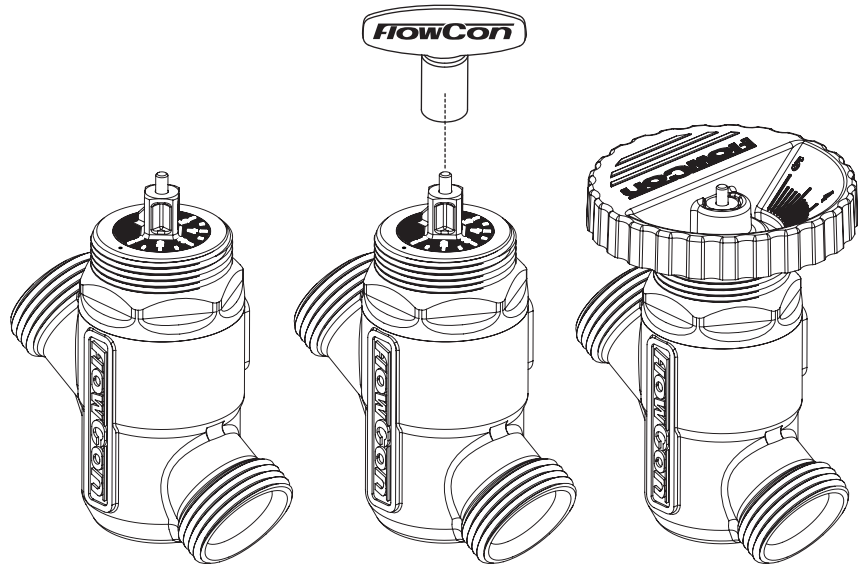

**Technical Data**

For further information and part number selection please see FlowCon tech note. For latest updates please see [www.flowcon.com](http://www.flowcon.com).

		FlowCon UniQ® DN15/20
Static Pressure	(kPa)	2500
	(psi)	360
Temperature Rating (media / ambient)	(°C)	-20 to +100 / +1 to +50
	(°F)	-4 to +212 / +34 to +122
Pressure Differential	(kPaD)	10-200
	(psid)	1.5-29
Flow Rate	(l/sec)	0.0056-0.2086
	(GPM)	0.089-3.305



A Griswold Controls LLC./FlowCon International Company

[www.flowcon.com](http://www.flowcon.com)

D E N M A R K . D U B A I . U S A . S I N G A P O R E

# FlowCon UniQ® 15-20mm

*Dynamic Self Balancing Control Valve*



## SPECIFICATIONS

Static pressure:	2500 kPa / 360 psi
Ambient temperature:	+1°C to +50°C / +34°F to +122°F
Media temperature <sup>1</sup> :	-20°C to +100°C / -4°F to +212°F
Material:	
- Plastic components (internal):	Glass-reinforced PSU/PPS/POM
- Metal components (internal):	Stainless steel
- O-rings and seat:	EPDM
- Housing:	Forged brass ASTM CuZn40Pb2
Maximum close off pressure:	200 kPaD / 29 psid
Maximum operational ΔP:	200 kPaD / 29 psid
Shut-off leakage:	ANSI / FCI 70-2 2006 / IEC 60534-4 - Class IV
Flow rate range:	0.0056-0.2086 l/sec / 0.089-3.305 GPM
End connections:	Fixed female DN15/20 ISO 20mm male ISO suitable for DN15 EuroCone according to EN215, Annex A Multiple union end connections

Note 1: Stated temperature rating is defined due to no external condensation.

## SPECIFICATIONS (...continued)

### FlowCon Actuators:

FlowCon Actuator <sup>2</sup>	EV.0.2	EV.0.3	EV.0.4	EV.0.5	EV.1.3	EV.1.4
Supply voltage	24V AC -10%/+20%, 50/60Hz	230V AC ±10%, 50/60Hz	24V AC/DC -10%/+20%, 50/60Hz	120V AC ±10%, 50/60Hz	230V AC ±10%, 50/60 Hz	24V AC/DC -10%/+20%, 50/60 Hz
Type	Thermal	Thermal	Thermal	Thermal	Thermal	Thermal
Power consumption	1.0 watt	1.0 watt	1.0 watt	1.0 watt	1.0 watt	1.0 watt
Control signal	0-10V DC normally closed <sup>3</sup>	ON/OFF normally closed <sup>3</sup>	ON/OFF normally closed <sup>3</sup>	ON/OFF normally closed <sup>3</sup>	ON/OFF normally closed <sup>3</sup>	ON/OFF normally closed <sup>3</sup>
Failsafe function	Yes	Yes	Yes	Yes	Yes	Yes
End switch	No	No	No	No	Yes	Yes
Operation time	Approx. 2 min	Approx. 4 min	Approx. 4 min	Approx. 4 min	Approx. 4 min	Approx. 4 min
Ambient temperature	0°C to +60°C	0°C to +60°C	0°C to +60°C	0°C to +60°C	0°C to +60°C	0°C to +60°C
Protection	IP54, class III	IP54, class II	IP54, class III	IP54, class II	IP54, class II	IP54
Cable	Plug-in, 3 wires x 0.22mm <sup>2</sup> PVC, standard 1 meter	Fixed, 2 wires x 0.75mm <sup>2</sup> PVC, standard 1 meter	Fixed, 2 wires x 0.75mm <sup>2</sup> PVC, standard 1 meter	Fixed, 2 wires x AWG18 (0.82mm <sup>2</sup> ) PVC, standard 1 meter	Fixed, 4 wires x 0.75mm <sup>2</sup> PVC, standard 1 meter	Fixed, 4 wires x 0.75mm <sup>2</sup> PVC, standard 1 meter
Weight <sup>4</sup>	0.11 kg	0.10 kg	0.10 kg	0.10 kg	0.15 kg	0.15 kg

Note 2: FlowCon warranty is voided using other actuators than supplied or recommended by FlowCon International.

Note 3: To ensure that the valve is in an open position during commission of the system, the actuator will be delivered in a normal open position and remain in this position until it is electrically operated first time.

Note 4: Weight without adaptor ring, but with wire.

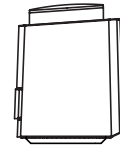
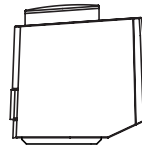

FlowCon EV.0.2 / EV.1.X    FlowCon EV.0.3 / EV.0.4 / EV.0.5

FlowCon Actuator <sup>5</sup>	FN.0.3	FN.1.4	FN.5.2	FN.5.4	FN.6.2
Supply voltage	110/230V AC ±10%, 50/60 Hz	24V AC/DC ±10%, 50/60 Hz	24V AC/DC ±10%, 50/60 Hz	24V AC/DC ±10%, 50/60 Hz	24V AC/DC ±10%, 50/60 Hz
Type	Electrical, Bi-directional synchronous motor				
Power consumption	5VA	6VA, 10VA peaks	5VA	5VA	6VA, 10VA peaks
Control signal	Digital (2-position/3-point floating)	Digital (2-position/3-point floating)	Analog 0(2)-10V DC	Digital (2-position/3-point floating)	Analog 0(2)-10V DC
Feedback	No	No	Yes, 0(2)-10V DC	No	Yes, 0(2)-10V DC
Failsafe function	No	Yes	No	No	Yes
Auto stroke	No	No	Yes	No	Yes
Operation time	50 Hz: 18.5 sec/mm	50 Hz: 18.5 sec/mm	50 Hz: 18.5 sec/mm	50 Hz: 18.5 sec/mm	50 Hz: 19 sec/mm
Ambient temperature	-18°C to +50°C				
Humidity rating	<95% no condensation				
Protection	IP54, class II				
Cable	Fixed, 3 wires 22 AWG halogen free cable, 1 meter	Fixed, 4 wires 22 AWG halogen free cable, 1 meter	Fixed, 4 wires 22 AWG halogen free cable, 1 meter	Fixed, 3 wires 22 AWG halogen free cable, 1 meter	Fixed, 4 wires 22 AWG halogen free cable, 1 meter
Closing point adjustment	During operation the actuator will self-adjust according to the closing point of the valve				
Weight	0.25 kg	0.30 kg	0.25 kg	0.25 kg	0.30 kg

Note 5: FlowCon warranty is voided using other actuators than supplied or recommended by FlowCon International.

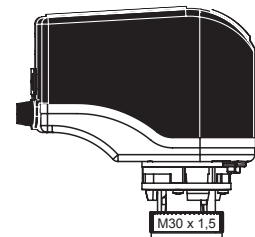
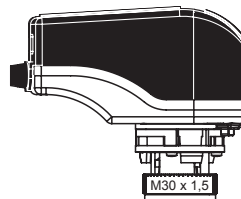

FlowCon FN.0.X / FN.5.X

FlowCon FN.1.X / FN.6.2

## DIMENSIONS AND WEIGHTS (NOMINAL) (measured in mm unless noted)

Model no.	Valve size	Thread	L	H1	H2 EV.0.2/1.X actuator	H3 EV.0.3-0.5 actuator	H4 FN.0.X/5.X actuator	H5 FN.1.X/6.2 actuator	End connections C <sup>6</sup>					Weight <sup>7</sup> (kgs.)	
									Size	ISO female	ISO male	Compression	Press		Universal
U.0.XX.1.I	DN15 F/F	G 1/2"	78	27	99	93	142	157	n/a	n/a	n/a	n/a	n/a	n/a	0.34
U.0.XX.2.I	DN20 F/F	G 3/4"							n/a	n/a	n/a	n/a	n/a	n/a	n/a
U.0.XX.3.XX.XX.I	DN15 M/M	G 3/4"	70	27	99	93	142	157	15	32.7	29.0	9.4	35.6	4.1	0.28
									18	n/a	n/a				

Note 6: Add end connection length to body length.

Note 7: Weight does not include end connections or actuator.

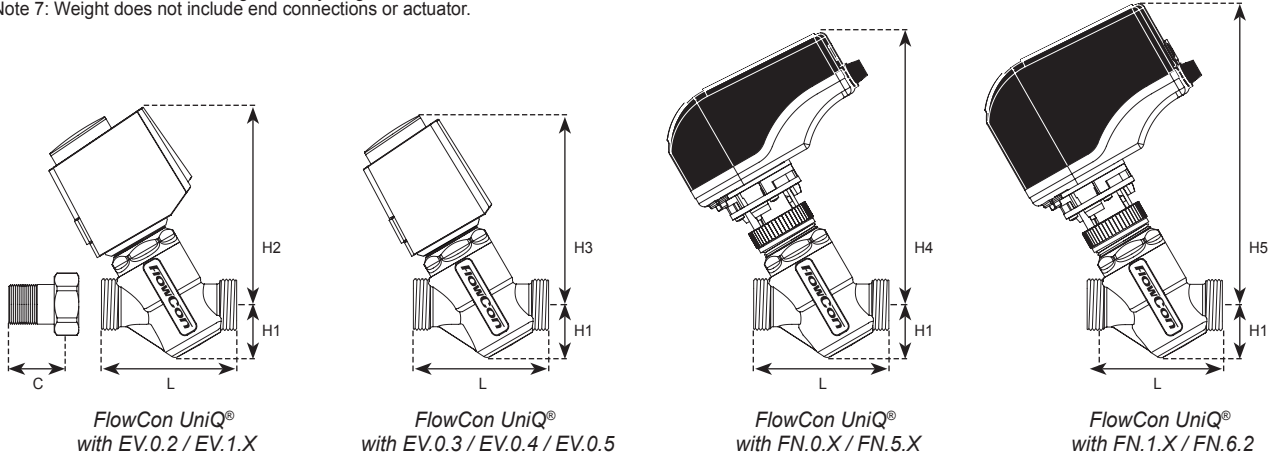

## MODEL NUMBER SELECTION

U . 0 . . . . . I

Insert flow range:  
**0**=low flow

Insert type of actuator:  
**02**=EV.0.2   **03**=EV.0.3   **04**=EV.0.4   **05**=EV.1.3   **06**=EV.1.4   **07**=EV.0.5  
**32**=FN.5.2   **33**=FN.0.3   **34**=FN.5.4   **42**=FN.6.2   **44**=FN.1.4

Insert type of body:  
**1**=DN15 female/female   **2**=DN20 female/female   **3**=20mm male (ISO) suitable for DN15 EuroCone

Insert connection size and type, union end<sup>8</sup>:  
 (- leave blank if female/female body is required)

Body size	Female threaded	Male threaded	Compression	Press <sup>9</sup>	Universal
EuroCone end	<b>AG</b> =15mm=1/2"	<b>CG</b> =15mm=1/2" <b>CU</b> =20mm=3/4"	<b>HG</b> =15mm <b>HR</b> =18mm	<b>FG</b> =15mm <b>FR</b> =18mm	<b>EX</b> =one-size

Insert connections standard:  
**I**=ISO (standard)

Example: U.0.02.3.CG.CG.I=FlowCon UniQ<sup>®</sup> with a 24V thermo modulating actuator and 15mm ISO male union end connections.

Note 8: Other end connections and sizes available upon request.

Note 9: Including universal fitting.

## WIRING INSTRUCTION

FlowCon EV.0.2  
 FlowCon EV.0.3 / 0.4  
 FlowCon EV.0.5  
 FlowCon EV.1.3 / EV.1.4

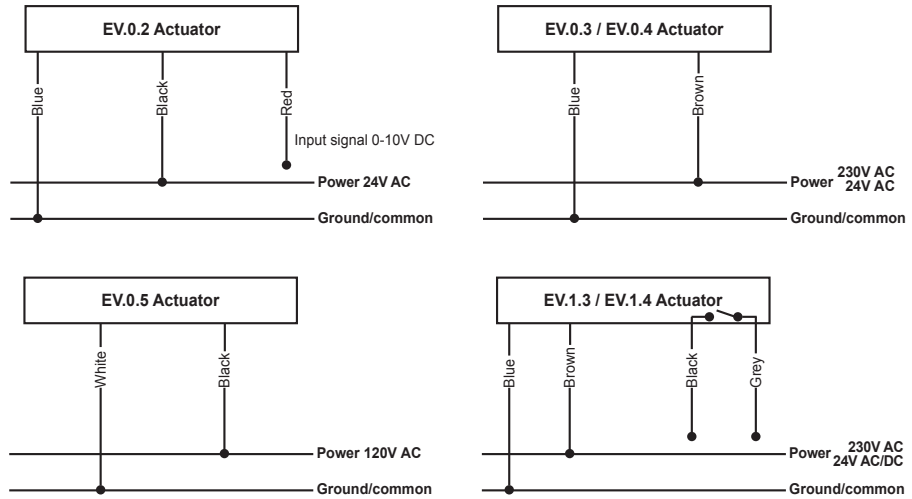

FlowCon FN.1.2 / 5.2 / 6.2

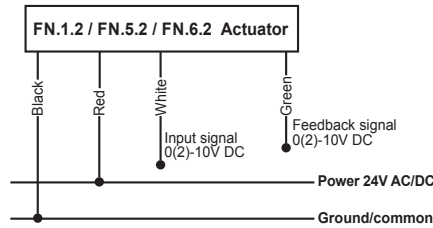

FlowCon FN.0.3

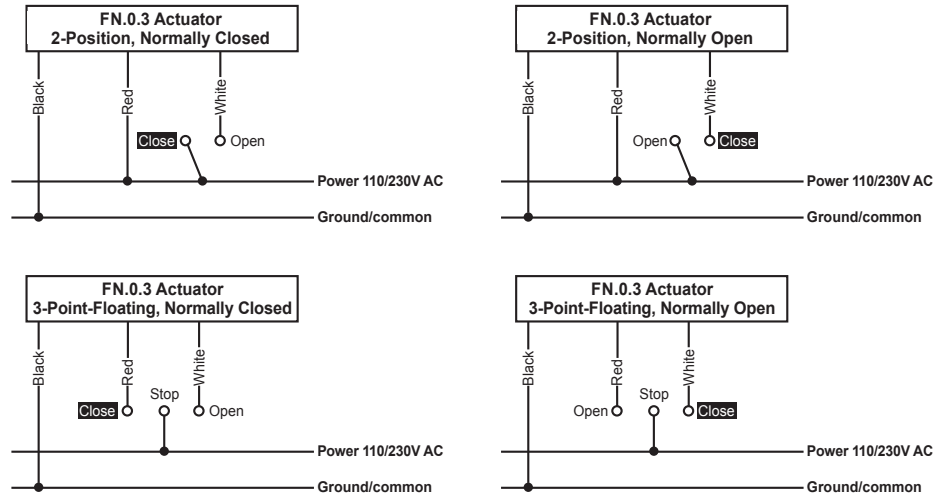

## WIRING INSTRUCTION (...continued)

### FlowCon FN.1.4

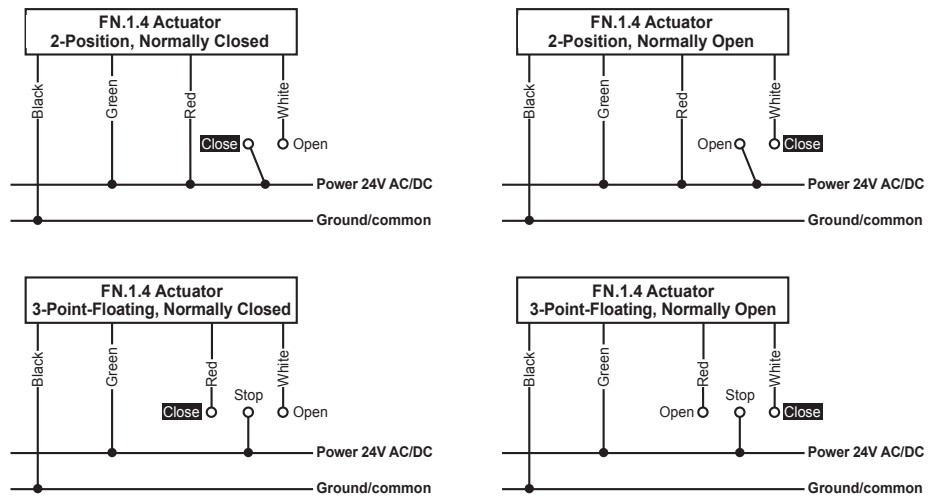

### FlowCon FN.5.4

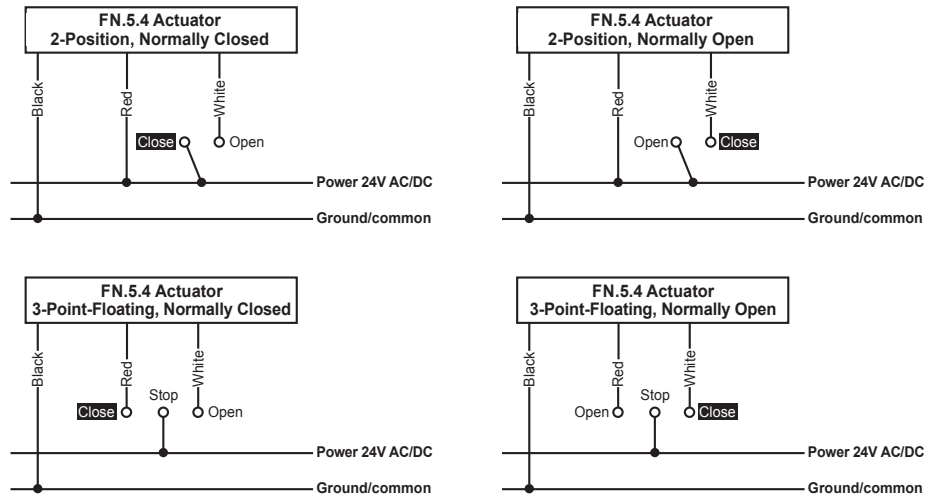

## DESCRIPTION

The FlowCon UniQ® is a self balancing dynamic flow control valve that is pressure independent. Each valve has an adjustable maximum flow rate setting maintaining a full stroke to enable flow limitation and balancing to the coil or zone that the valve is controlling.

The valve comes in three different body types, i.e DN15 female/female, DN20 female/female and 20mm male (ISO) suitable for DN15 EuroCone.

For use in fan-coil units, VAV applications and cooling ceilings for activation of the heating or cooling.

## MAXIMUM FLOW RATE LIMITATION SETTINGS - VALVE SIZE DN15-DN20

FlowCon UniQ®			Setting
15/20mm · 1/2" / 3/4"			
10 <sup>10</sup> -200 kPaD · 1.5 <sup>10</sup> -29 psid			
l/sec	l/hr	GPM	
0.0056	20.3	0.089	1.0
0.0100	36.0	0.158	1.1
0.0157	56.7	0.249	1.2
0.0223	80.1	0.353	1.3
0.0291	105	0.461	1.4
0.0360	129	0.570	1.5
0.0426	153	0.675	1.6
0.0489	176	0.775	1.7
0.0549	198	0.869	1.8
0.0604	218	0.957	1.9
0.0657	237	1.041	2.0
0.0708	255	1.121	2.1
0.0757	273	1.199	2.2
0.0806	290	1.277	2.3
0.0856	308	1.356	2.4
0.0908	327	1.439	2.5
0.0963	347	1.526	2.6
0.1022	368	1.618	2.7
0.1084	390	1.716	2.8
0.1149	414	1.820	2.9
0.1218	439	1.930	3.0
0.1291	465	2.044	3.1
0.1365	491	2.162	3.2
0.1440	518	2.281	3.3
0.1515	546	2.400	3.4
0.1589	572	2.516	3.5
0.1658	597	2.627	3.6
0.1723	620	2.730	3.7
0.1782	642	2.823	3.8
0.1833	660	2.903	3.9
0.1874	675	2.969	4.0
0.1907	686	3.020	4.1
0.1929	695	3.056	4.2
0.1943	699	3.078	4.3
0.1947	701	3.084	4.4
0.1951	702	3.091	4.5
0.1952	703	3.092	4.6
0.1958	705	3.102	4.7
0.1976	711	3.130	4.8
0.2015	725	3.192	4.9
0.2086	751	3.305	5.0

Nominal flow rate

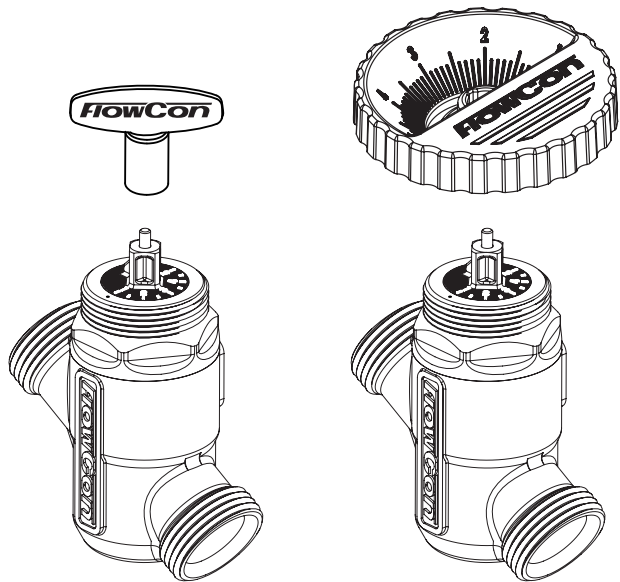

Use the special designed key (FlowCon part no. ACC0001) for a rough setting of the valve or use the large FlowCon adjustment wheel for a micrometer setting with indication of each of the 41 settings (FlowCon part no. ACC0006).

A setting of 3.4 corresponds to a max. flow rate of 0.1515 l/sec.

Accuracy: Greatest of either ±10% of controlled flow rate or ±5% of maximum flow rate.

Note 10: Min. DP=10 x √Setting

## ACCESSORIES

- Adjustment key: ACC0001.
- Adjustment wheel: ACC0006.



Part no. ACC0001



Part no. ACC0006

## GENERAL SPECIFICATIONS

1. **PRESSURE INDEPENDENT DYNAMIC CONTROL VALVE FLOWCON UniQ®**
  - 1.1. Contractor shall install the pressure independent dynamic control valve where indicated in drawings.
  - 1.2. Valve shall be an electric, dynamic, modulating, 2-way, pressure independent control device.
  - 1.3. Pressure independent dynamic control valve shall accurately control flow, independent of system pressure fluctuation.
  - 1.4. Maximum flow setting shall be adjustable to 41 settings within the range of the valve size.
  
2. **VALVE ACTUATOR, ELECTRIC / THERMO-ELECTRIC**
  - 2.a. **FlowCon EV-actuators**
    - 2.a.1 Valve actuator housing shall be rated to IP54.
    - 2.a.2 Actuator shall be driven by 24V, 120V or 230V AC voltage, and shall depending on actuator choice accept 0-10V DC or ON/OFF control signal.
    - 2.a.3 Actuator shall use full stroke and provide full authority.
    - 2.a.4 Actuator shall have visible indication of stroke position.
  - OR....
  - 2.b. **FlowCon FN-actuators**
    - 2.b.1 Valve actuator housing shall be rated to IP54.
    - 2.b.2 Actuator shall be driven by 24V AC/DC or 110V/230V AC, and shall depending on actuator choice accept 0(2)-10V DC, 3-point floating or 2-position control signal.
    - 2.b.3 Actuator shall use full stroke and provide full authority.
    - 2.b.4 Actuator shall have visible indication of stroke position.
    - 2.b.5 Feedback signal 0(2)-10V DC to the control system shall be standard on modulating version.
    - 2.b.6 Optional failsafe function shall be available on 24V AC/DC versions.
    - 2.b.7 Optional auto stroke function shall be available on 24V version.
    - 2.b.8 Manual override shall be possible without use of tools.
  
3. **VALVE HOUSING**

Valve housing shall consist of forged brass ASTM CuZn40Pb2, rated at no less than 2500 kPa static pressure and +100°C.
  
4. **FLOW REGULATION UNIT**
  - 4.1. Flow regulation unit shall consist of glass-reinforced PPS, PSU and POM with EPDM diaphragm and sealings.
  - 4.2. Flow regulation unit shall be externally adjustable to 1 of 41 flow rates; minimum range shall be capable of being activated by minimum 10 kPaD operation ranges; and shall be capable of controlling the flow within  $\pm 10\%$  of rated flow or  $\pm 5\%$  of maximum flow.

## APPLICATION AND SCHEMATIC EXAMPLE

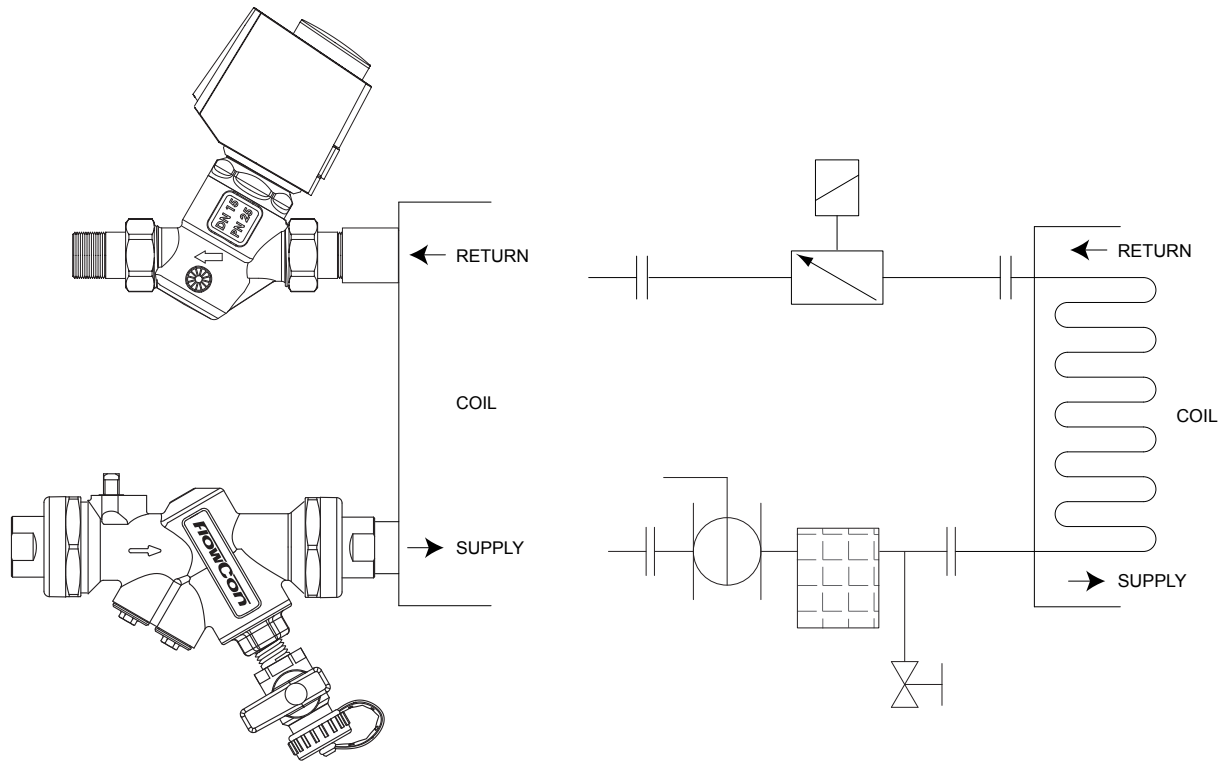

## UPDATES

For latest updates please see [www.flowcon.com](http://www.flowcon.com)

FlowCon International can accept no responsibility for possible errors in any printed material. All rights reserved.

# FlowCon Green



*100% Authority  
Pressure Independent Control Valve*

# FlowCon Green

## Pressure Independent Control Valves



The FlowCon Green insert is designed as a 3-in-1 solution combining a full stroke modulation control valve, an automatic balancing valve and a differential pressure control valve. This new insert includes an innovative self-adjustment feature, which enables each valve continuously to self-balance. This ensures delivery of precisely the flow rate required by each terminal unit, independent of pressure fluctuations in the hydronic system. Each FlowCon Green insert can also be adjusted to set an accurate maximum flow rate limit to each circuit without stroke limitation.

The FlowCon Green insert can be used in several different applications within heating or cooling such as fan-coil units, air-handler units and other terminal units - wherever dynamic balancing and fully accurate temperature control are required, the FlowCon Green insert will be the ideal choice. It will be the easy solution to both designers, installers and end-users due to its user-friendly complete solution in one body and with one insert.

### Valve Choice

The FlowCon Green insert can be used with the following FlowCon valves:

- FlowCon A (DN15/20/25)
- FlowCon AB (DN15/20/25/32)
- FlowCon ABV1 (DN15/20/25)
- FlowCon ABV2 (DN25/32/40)

### 100% Valve Authority

The FlowCon Green is a 100% authority pressure independent flow control valve which instantaneously self-balance at all points of operation, even when there is variance in pressure differential.

#### 100% Authority Pressure Independent

As long as the pressure differential across the valve is within the operating range, the Kv of the valve is variable, being continuously regulated to keep the control

valve in constant authority. The FlowCon Green insert will in other words always use full stroke of the spindle offering the 100% authority for any of its 41 maximum flow settings.

### Features and Benefits

- **3-in-1 combi valve**, modulating control valve, dynamic flow limiter and differential pressure control valve in one body.
- **Differential pressure independent**.
- **Full stroke modulation** at any design flow.
- **100% authority** for any of the insert's flow setting.
- **Automatic system balancing**, the correct flow rate for each circuit is achieved automatically.
- **Dynamic balancing**, the correct flow rate is maintained as each valve continuously compensates for pressure fluctuations in the system.
- **Field adjustable**, flow rate can be changed on demand without removing the insert from the valve body.
- **Elimination of branch or "partner" balancing valves** which results in fewer total valves used in each project.
- **Easily accessible insert** for flow rate adjustment or maintenance.
- **Accuracy**: Greatest of either  $\pm 10\%$  of controlled flow rate or  $\pm 5\%$  of maximum flow rate.
- **Up to 41 different flow curves** in one and the same insert.
- **Choice of actuator**, electrical actuators: 0(2)-10V modulating, 3-point floating or 2-position, or thermal actuators: 0-10V modulating or ON/OFF.
- **Built-in isolation ball valve** (FlowCon ABV).
- **Pressure/temperature measurement plugs** available for verifying operating differential pressure or checking  $\Delta T$  across the coil (FlowCon AB / ABV).
- **Double union end connection** for ease of installation and wide selection of end fittings (FlowCon ABV) or **fixed end** female-by-female threaded (FlowCon A / AB).

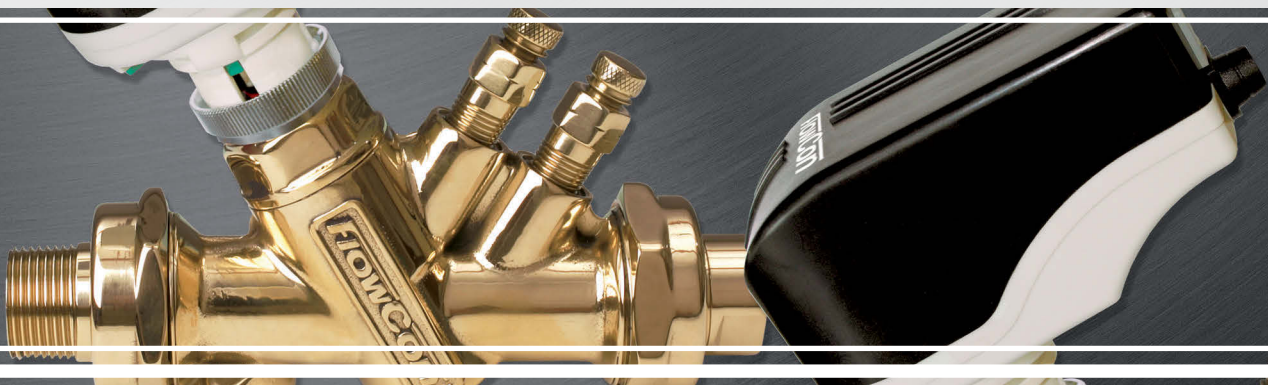

FlowCon Green									
Insert: 20mm, 3/4"					Insert: 40mm, 1 1/2"				
16-200 kPaD · 2.3-29 psid			30-400 kPaD · 4.4-58 psid			16-400 kPaD* · 2.3-58 psid*			Setting
Green.0 (grey o-ring)			Green.1 (black o-ring)			Green.2 (black o-ring)			
l/sec	l/hr	GPM	l/sec	l/hr	GPM	l/sec	l/hr	GPM	
-	-	-	0.0178	64	0.282	0.240	865	3.81	1.0
0.0103	37	0.163	0.0393	142	0.624	0.282	1010	4.46	1.1
0.0233	84	0.370	0.0580	209	0.920	0.322	1160	5.10	1.2
0.0322	116	0.510	0.0743	268	1.180	0.361	1300	5.72	1.3
0.0419	151	0.664	0.0887	319	1.41	0.399	1430	6.32	1.4
0.0500	180	0.792	0.102	366	1.61	0.435	1570	6.90	1.5
0.0569	205	0.902	0.113	408	1.80	0.471	1700	7.47	1.6
0.0650	234	1.03	0.124	446	1.96	0.506	1820	8.02	1.7
0.0719	259	1.14	0.134	482	2.12	0.540	1940	8.56	1.8
0.0781	281	1.24	0.143	516	2.27	0.573	2060	9.08	1.9
0.0839	302	1.33	0.152	549	2.42	0.605	2180	9.59	2.0
0.0889	320	1.41	0.161	580	2.56	0.636	2290	10.1	2.1
0.0942	339	1.49	0.170	611	2.69	0.667	2400	10.6	2.2
0.0981	353	1.55	0.178	641	2.82	0.696	2510	11.0	2.3
0.103	371	1.63	0.186	671	2.95	0.725	2610	11.5	2.4
0.106	381	1.68	0.194	700	3.08	0.753	2710	11.9	2.5
0.109	394	1.73	0.202	728	3.21	0.780	2810	12.4	2.6
0.113	406	1.79	0.210	756	3.33	0.807	2900	12.8	2.7
0.115	414	1.82	0.218	783	3.45	0.832	3000	13.2	2.8
0.119	428	1.88	0.225	810	3.56	0.858	3090	13.6	2.9
0.122	439	1.93	0.232	835	3.68	0.882	3180	14.0	3.0
0.125	449	1.98	0.239	860	3.79	0.906	3260	14.4	3.1
0.127	458	2.02	0.245	883	3.89	0.930	3350	14.7	3.2
0.130	468	2.06	0.252	906	3.99	0.953	3430	15.1	3.3
0.133	477	2.10	0.257	927	4.08	0.975	3510	15.5	3.4
0.135	486	2.14	0.263	946	4.17	0.997	3590	15.8	3.5
0.137	494	2.17	0.268	965	4.25	1.02	3670	16.1	3.6
0.140	503	2.21	0.273	982	4.32	1.04	3740	16.5	3.7
0.142	511	2.25	0.277	998	4.39	1.06	3820	16.8	3.8
0.144	518	2.28	0.281	1010	4.46	1.08	3890	17.1	3.9
0.146	526	2.31	0.285	1020	4.51	1.10	3960	17.4	4.0
0.148	532	2.34	0.288	1040	4.57	1.12	4030	17.7	4.1
0.149	538	2.37	0.291	1050	4.61	1.14	4100	18.1	4.2
0.151	544	2.39	0.294	1060	4.66	1.16	4170	18.4	4.3
0.153	549	2.42	0.296	1070	4.70	1.18	4240	18.7	4.4
0.154	553	2.43	0.299	1080	4.73	1.20	4300	19.0	4.5
0.155	559	2.46	0.301	1080	4.77	1.21	4370	19.2	4.6
0.156	563	2.48	0.303	1090	4.80	1.23	4440	19.5	4.7
0.158	567	2.50	0.305	1100	4.83	1.25	4500	19.8	4.8
0.159	571	2.51	0.307	1100	4.86	1.27	4570	20.1	4.9
0.160	575	2.53	0.308	1110	4.89	1.29	4630	20.4	5.0

Accuracy: Greatest of either ±10% of controlled flow rate or ±5% of maximum flow rate.  
 \*at setting 2.6.

### Principle of Operation

On closer examination of the inner workings of the FlowCon Green, the function is best described as 2 valves in 1. The second valve (V2) regulates the pressure differential across the first valve (V1) by means of a rolling diaphragm element counteracted by a spring. The first valve is a calibrated variable orifice device adjusted by the actuator (similar to a standard modulating control valve).

The diaphragm reacts to the system and regulates the pressure differential across the actuated control valve orifice to maintain its flow rate.

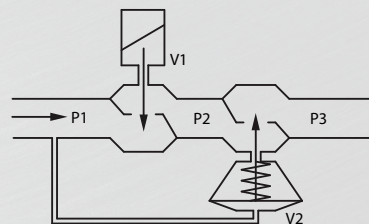

When pre-setting the maximum flow rate, the inlet orifice is changed in size sideways which does not interfere with the length of the stroke. When modulating, the orifice areas are affected by the actuator using the full stroke which results in the fact that the orifice area is changed in size in a vertical movement.

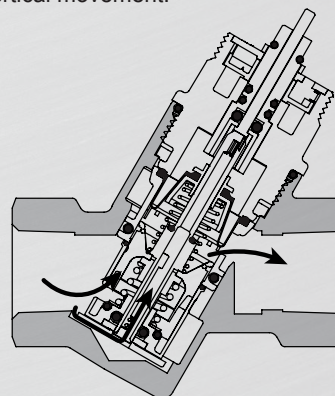

## Hydronic Balance

The insert can be pre-set to limit the working range of the valve which limits the maximum flow rate through the valve. Consequently, hydronic balance is achieved automatically without the use of additional balancing valves.

### Pre-setting the Maximum Flow Rate

The valve is adjusted to a maximum flow rate limit by setting the scale located on the top of the FlowCon Green insert. The setting indicates one of 41 possible maximum flow rates from e.g. 0.240-1.29 l/sec on FlowCon Green.2 but since the setting is stepless any flow rate in between will be obtainable. The setting is done by means of a special FlowCon key. With the actuator mounted, the pre-setting is “sealed” and the FlowCon Green insert eliminates any flow above the design flow.

For re-adjustment, simply disconnect power from the actuator and re-move the actuator from the insert. Then dial in the new required maximum flow and re-apply the actuator and connect power again.

### Actuator Mounting and Self-Calibration

When using the actuator, always be sure that power supply is turned off and the actuator is in a fully open position (turn the actuator to this position if required) before fitting the actuator to the insert.

For further information please see the installation and operation instruction manual.

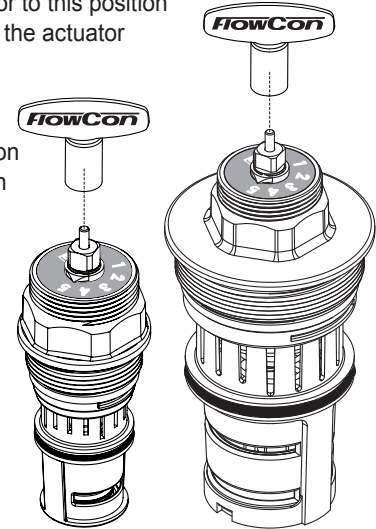

## Technical Data

For further information and part number selection please see FlowCon tech note.

For latest updates please see [www.flowcon.com](http://www.flowcon.com).

		A/AB/ABV DN15/20/25 with Green insert	AB DN25/32 with Green insert ABV DN25/32/40 with Green insert
Static Pressure	(kPa)	2500	2500
	(psi)	360	360
Temperature Rating (media / ambient)	(°C)	-20 to +120 / 0 to +50	-20 to +120 / 0 to +50
	(°F)	-4 to +248 / +32 to +122	-4 to +248 / +32 to +122
Pressure Drop Data		NOTE: For pump head calculations, add the minimum pressure differential for the index circuit to the other components pressure losses (i.e. valves, coil, etc.)	
Valve Body	(Kv-value) (m³/hr)	3.1	12.5
	(Cv-value) (GPM)	3.6	14.5

FlowCon Green insert		Green.0 (grey o-ring)	Green.1 (black o-ring)	Green.2 (black o-ring)
Pressure Differential	(kPaD)	16-200	30-400	16-400 (at setting 2.6)
	(psid)	2.3-29	4.4-58	2.3-58 (at setting 2.6)
Flow Rate	(l/sec)	0.0103-0.160	0.0178-0.308	0.240-1.29
	(GPM)	0.163-2.53	0.282-4.89	3.81-20.4

**FlowCon**  
international

A Griswold Controls LLC./FlowCon International Company

[www.flowcon.com](http://www.flowcon.com)

D E N M A R K · D U B A I · U S A · S I N G A P O R E

# FlowCon Green 15-40mm

## Pressure Independent Control Valves



### SPECIFICATIONS

**Insert:**

Static pressure:	2500 kPa / 360 psi
Ambient temperature:	+1°C to +50°C / +34°F to +122°F
Media temperature <sup>1</sup> :	-20°C to +120°C / -4°F to +248°F
Material:	
- Insert:	Glass-reinforced PSU/POM/PPS
- Diaphragm:	Green insert 20mm: EPDM Green insert 40mm: Hydrogenated acrylonitrile-butadiene-rubber
- Internal metal components:	Stainless steel
- O-rings:	EPDM
- Cone:	Green insert 20mm: PPS Green insert 40mm: PPS/EPDM
Maximum close off pressure:	Green insert 20mm: 600 kPaD / 87 psid Green insert 40mm: 400 kPaD / 58 psid
Maximum operational $\Delta P$ :	400 kPaD / 58 psid
Shut-off leakage:	ANSI / FCI 70-2 2006 / IEC 60534-4 - Class IV
Flow rate range:	Green insert 20mm: 0.0103-0.308 l/sec / 0.163-4.89 GPM Green insert 40mm: 0.240-1.29 l/sec / 3.81-20.4 GPM

**Valve:**

Material:	
- Body:	Forged brass ASTM CuZn40Pb2
- Ball valve:	ABV: Chemically nickel plated brass ball
End connections:	A: (only available for Green insert 20mm) Fixed female ISO or NPT AB: Fixed female ISO or NPT ABV: Union end connection in brass alloy ISO or NPT.

Note 1: Stated temperature rating is defined due to no external insert condensation.

## SPECIFICATIONS (...continued)

### FlowCon Actuators:

FlowCon Actuator <sup>2</sup>	FT.0.2 <sup>3</sup>	FT.0.3 <sup>3</sup>	FT.0.4 <sup>3</sup>
Supply voltage	24V AC -10%... +20%, 50/60Hz	230V AC ±10%, 50/60Hz	24V AC/DC -10%... +20%, 50/60Hz
Type	Thermal	Thermal	Thermal
Power consumption	1.2W	1.2W	1.2W
Control signal	Analog 0-10V, Normally closed	ON/OFF, Normally closed	ON/OFF, Normally closed
Failsafe function	Yes	Yes	Yes
Operation time <sup>4</sup>	App. 3.5 minutes	App. 4.5 minutes	App. 4.5 minutes
Ambient temperature	0°C to +60°C	0°C to +60°C	0°C to +60°C
Protection	IP54 including upside-down, class III	IP54 including upside-down, class II	IP54 including upside-down, class III
Cable	Plug-in, 1 meter	Fixed, 1 meter	Fixed, 1 meter
Weight	0.12 kg	0.11 kg	0.11 kg

Note 2: FlowCon warranty is voided using other actuators than supplied by FlowCon International.

Note 3: Please note if mounted on FlowCon Green.2 specified leakage rate to be exceeded.

Note 4: Closing time is approximately the double dependent on ambient temperature.

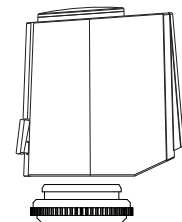

FlowCon FT.0.2

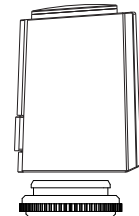

FlowCon FT.0.3/0.4

FlowCon Actuator <sup>5</sup>	FN.0.2	FN.0.3	FN.0.4
Supply voltage	24V AC/DC ±10%, 50/60 Hz	110/230V AC ±10%, 50/60 Hz	24V AC/DC ±10%, 50/60 Hz
Type	Electrical, Bi-directional synchronous motor		
Power consumption	5VA		
Control signal	Analog 0(2)-10V DC	Digital (2-position / 3-point floating)	Digital (2-position / 3-point floating)
Feedback	Yes, 0(2)-10V DC	No	No
Failsafe function	No	No	No
Auto stroke	Yes	No	No
Operation time	50 Hz: 18.5 sec/mm		
Ambient temperature	-18°C to +50°C		
Humidity rating	<95% no condensation		
Protection	IP54, class II		
Cable	Fixed, 4 wires 22 AWG halogen free cable, 1 meter	Fixed, 3 wires 22 AWG halogen free cable, 1 meter	Fixed, 3 wires 22 AWG halogen free cable, 1 meter
Closing point adjustment	During operation the actuator will self-adjust according to the closing point of the valve		
Weight	0.25 kg		

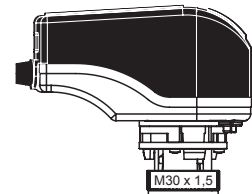

FlowCon FN.0.X

Note 5: FlowCon warranty is voided using other actuators than supplied by FlowCon International.

FlowCon Actuator <sup>6</sup>	FN.1.2	FN.1.4
Supply voltage	24V AC/DC ±10%, 50/60 Hz	
Type	Electrical, Bi-directional synchronous motor	
Power consumption	6VA, 10VA peaks	
Control signal	Analog 0(2)-10V DC	Digital (2-position / 3-point floating)
Feedback	Yes, 0(2)-10V DC	No
Failsafe function	Yes	Yes
Auto stroke	Yes	No
Operation time	50 Hz: 19 sec/mm	50 Hz: 18.5 sec/mm
Ambient temperature	-18°C to +50°C	
Humidity rating	<95% no condensation	
Protection	IP54, class II	
Cable	Fixed, 4 wires 22 AWG halogen free cable, 1 meter	
Closing point adjustment	During operation the actuator will self-adjust according to the closing point of the valve	
Weight	0.30 kg	

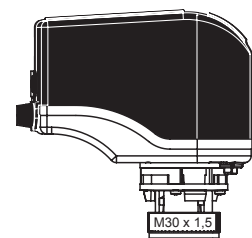

FlowCon FN.1.X

Note 6: FlowCon warranty is voided using other actuators than supplied by FlowCon International.

## DIMENSIONS AND WEIGHTS (NOMINAL) (measured in mm unless noted)

Model no.	Valve model	Valve size	Insert size	L	H1	H2 FT.0.2 act.	H3 FT.0.3/0.4 act.	H4 FN.0.X act.	H5 FN.1.X act.	End connections C <sup>7</sup>			Weight <sup>8</sup> (kgs.)	Kv <sup>9</sup> (m <sup>3</sup> /hr)
										ISO female	ISO male	Sweat		
G.X.XX.04	A	15	20	80	31	118	116	130	145	-	-	-	0.58	3.1
G.X.XX.05		20											0.53	
G.X.XX.06		25											0.56	
G.X.XX.01	AB	15	20	82	31	118	116	130	145	-	-	-	0.51	3.1
G.X.XX.02		20											0.56	
G.X.XX.07		25											0.62	
G.2.XX.14		25											1.85	
G.2.XX.15	32	1.69												
G.X.XX.03	ABV1	15	20	122	33	118	116	130	145	22	24	20	0.85	3.1
		20								22	25	20		
		25								-	39	22		
G.2.XX.17	ABV2	25	40	162	42	138	137	153	165	35	40	34	2.15	11.7
		32								33	40	34		
		40								33	42	-		

Note 7: Add end connection length to body length.  
 Note 8: Weight does not include end connections or actuator.  
 Note 9: For valve body.

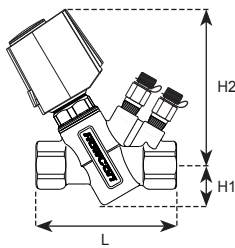

FlowCon AB DN15/20/25  
with FlowCon FT.0.2 actuator

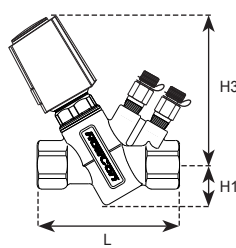

FlowCon AB DN15/20/25  
with FlowCon FT.0.3/0.4 act.

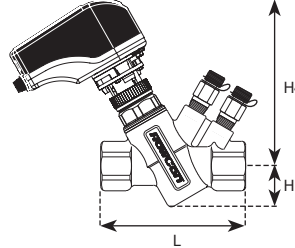

FlowCon AB DN15/20/25  
with FlowCon FN.0.X actuator

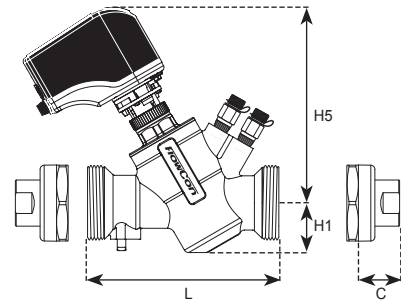

FlowCon ABV DN25/32/40  
with FlowCon FN.1.X actuator

## MODEL NUMBER SELECTION

Insert flow range:  
**0**=20mm insert low flow  
**1**=20mm insert medium flow  
**2**=40mm insert

Insert type of actuator:  
**22**=FT.0.2   **23**=FT.0.3   **24**=FT.0.4  
**32**=FN.0.2   **33**=FN.0.3   **34**=FN.0.4   **42**=FN.1.2   **44**=FN.1.4

Insert type of body:  
 20mm insert: **01**=AB15   **02**=AB20   **03**=ABV1   **04**=A15   **05**=A20   **06**=A25   **07**=AB25  
 40mm insert: **14**=AB25   **15**=AB32   **17**=ABV2

Insert p/t plug requirements:  
**B**=pressure/temperature plugs   **P**=taps plugged   - leave blank if A-body or no p/t plugs required

Insert inlet x outlet union end connections:   - leave blank if A- or AB-body or no end connections required

Body model and size	Female threaded	Male treaded	Sweat
G.0.XX.03, 15-25mm, 1/2"-1" G.1.XX.03, 15-25mm, 1/2"-1"	<b>E</b> = 15mm=1/2" <b>F</b> = 20mm=3/4"	<b>H</b> = 15mm=1/2" <b>I</b> = 20mm=3/4" <b>J</b> = 25mm=1"	<b>K</b> = 15mm <b>L</b> = 18mm <b>M</b> = 22mm
G.2.XX.17, 25-40mm, 1"-1 1/2"	<b>G</b> = 25mm=1" <b>P</b> = 32mm=1 1/4" <b>Q</b> = 40mm=1 1/2"	<b>J</b> = 25mm=1" <b>S</b> = 32mm=1 1/4" <b>T</b> = 40mm=1 1/2"	<b>N</b> = 28mm <b>W</b> = 35mm

Insert connections standard:  
**I**=ISO   **N**=NPT (NPT: not available on A25 and AB25 for 20mm insert)

Example: G.1.22.03.B.F.F.I=20mm FlowCon Green, medium flow, with an ABV1-body with p/t plugs and a 24V thermal modulating actuator and 20mm ISO female union end connections.

## WIRING INSTRUCTION

### FlowCon FT.0.2

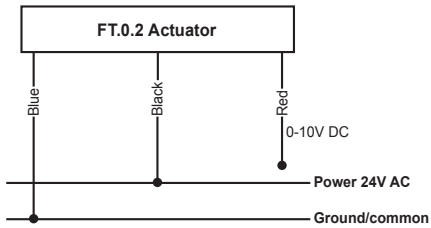

### FlowCon FT.0.3 and FT.0.4

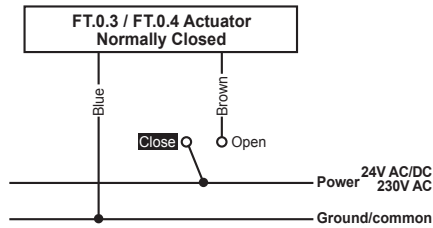

### FlowCon FN.0.2 and FN.1.2

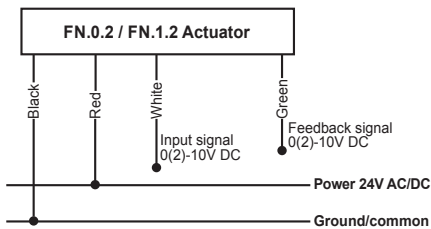

### FlowCon FN.0.3

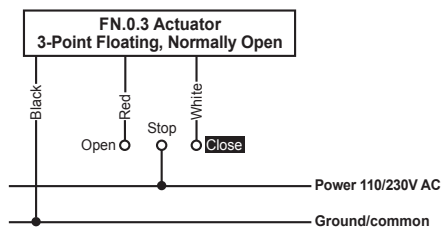
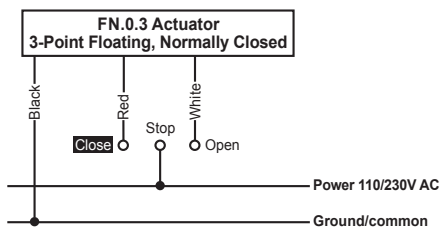
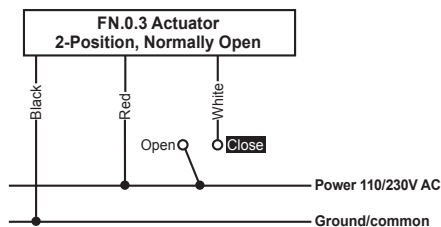
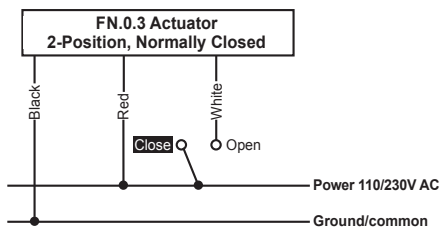

### FlowCon FN.0.4

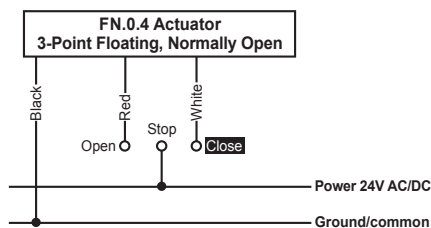
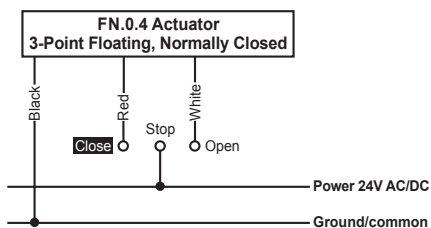
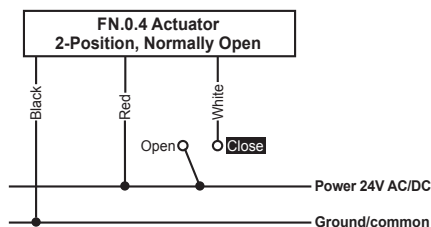
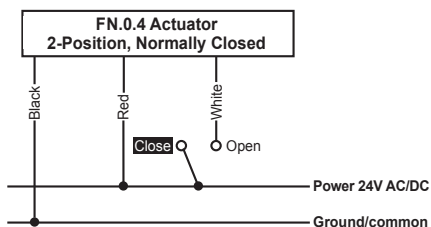

## WIRING INSTRUCTION (...continued)

### FlowCon FN.1.4

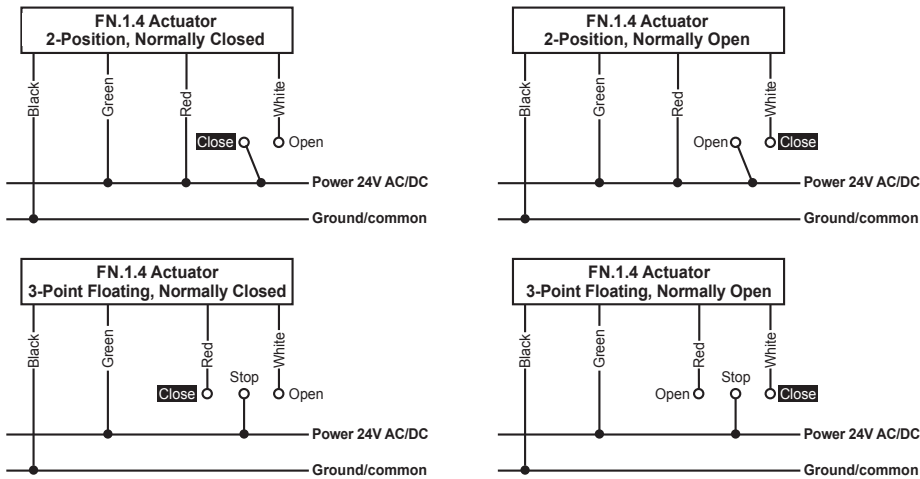

## DESCRIPTION

The FlowCon Green series is pressure independent control valves that are two-way, modulating to accept digital or analog input signals. The valves accept 0(2)-10V, 3-point floating or ON/OFF input signals. Each valve has an adjustable maximum flow rate setting maintaining a full stroke to enable flow limitation and balancing to the coil or zone that the valve is controlling.

For use in fan-coil units, VAV applications and cooling ceilings for activation of the heating or cooling. They are available in three different valve bodies, i.e. FlowCon A, AB or ABV.

## MAXIMUM FLOW RATE LIMITATION SETTINGS - VALVE SIZE DN15-DN40

FlowCon Green									
Insert size: 20mm · 3/4"						Insert size: 40mm · 1 1/2"			Setting
16-200 kPad · 2.3-29 psid			30-400 kPad · 4.4-58 psid			16-400 kPad · 2.3-58 psid (at setting: 2.6)			
FlowCon Green.0 (grey o-ring)			FlowCon Green.1 (black o-ring)			FlowCon Green.2 (black o-ring)			
l/sec	l/hr	GPM	l/sec	l/hr	GPM	l/sec	l/hr	GPM	
-	-	-	0.0178	64	0.282	0.240	865	3.81	1.0
0.0103	37	0.163	0.0393	142	0.624	0.282	1010	4.46	1.1
0.0233	84	0.370	0.0580	209	0.920	0.322	1160	5.10	1.2
0.0322	116	0.510	0.0743	268	1.180	0.361	1300	5.72	1.3
0.0419	151	0.664	0.0887	319	1.41	0.399	1430	6.32	1.4
0.0500	180	0.792	0.102	366	1.61	0.435	1570	6.90	1.5
0.0569	205	0.902	0.113	408	1.80	0.471	1700	7.47	1.6
0.0650	234	1.03	0.124	446	1.96	0.506	1820	8.02	1.7
0.0719	259	1.14	0.134	482	2.12	0.540	1940	8.56	1.8
0.0781	281	1.24	0.143	516	2.27	0.573	2060	9.08	1.9
0.0839	302	1.33	0.152	549	2.42	0.605	2180	9.59	2.0
0.0889	320	1.41	0.161	580	2.56	0.636	2290	10.1	2.1
0.0942	339	1.49	0.170	611	2.69	0.667	2400	10.6	2.2
0.0981	353	1.55	0.178	641	2.82	0.696	2510	11.0	2.3
0.103	371	1.63	0.186	671	2.95	0.725	2610	11.5	2.4
0.106	381	1.68	0.194	700	3.08	0.753	2710	11.9	2.5
0.109	394	1.73	0.202	728	3.21	0.780	2810	12.4	2.6
0.113	406	1.79	0.210	756	3.33	0.807	2900	12.8	2.7
0.115	414	1.82	0.218	783	3.45	0.832	3000	13.2	2.8
0.119	428	1.88	0.225	810	3.56	0.858	3090	13.6	2.9
0.122	439	1.93	0.232	835	3.68	0.882	3180	14.0	3.0
0.125	449	1.98	0.239	860	3.79	0.906	3260	14.4	3.1
0.127	458	2.02	0.245	883	3.89	0.930	3350	14.7	3.2
0.130	468	2.06	0.252	906	3.99	0.953	3430	15.1	3.3
0.133	477	2.10	0.257	927	4.08	0.975	3510	15.5	3.4
0.135	486	2.14	0.263	946	4.17	0.997	3590	15.8	3.5
0.137	494	2.17	0.268	965	4.25	1.02	3670	16.1	3.6
0.140	503	2.21	0.273	982	4.32	1.04	3740	16.5	3.7
0.142	511	2.25	0.277	998	4.39	1.06	3820	16.8	3.8
0.144	518	2.28	0.281	1010	4.46	1.08	3890	17.1	3.9
0.146	526	2.31	0.285	1020	4.51	1.10	3960	17.4	4.0
0.148	532	2.34	0.288	1040	4.57	1.12	4030	17.7	4.1
0.149	538	2.37	0.291	1050	4.61	1.14	4100	18.1	4.2
0.151	544	2.39	0.294	1060	4.66	1.16	4170	18.4	4.3
0.153	549	2.42	0.296	1070	4.70	1.18	4240	18.7	4.4
0.154	553	2.43	0.299	1080	4.73	1.20	4300	19.0	4.5
0.155	559	2.46	0.301	1080	4.77	1.21	4370	19.2	4.6
0.156	563	2.48	0.303	1090	4.80	1.23	4440	19.5	4.7
0.158	567	2.50	0.305	1100	4.83	1.25	4500	19.8	4.8
0.159	571	2.51	0.307	1100	4.86	1.27	4570	20.1	4.9
0.160	575	2.53	0.308	1110	4.89	1.29	4630	20.4	5.0

Nominal flow rate

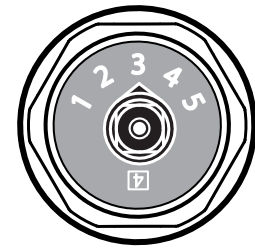

A micrometer setting of 3.4 as illustrated beside corresponds to a maximum flow rate of

0.133 l/sec (Green.0),  
0.257 l/sec (Green.1),  
0.975 l/sec (Green.2).

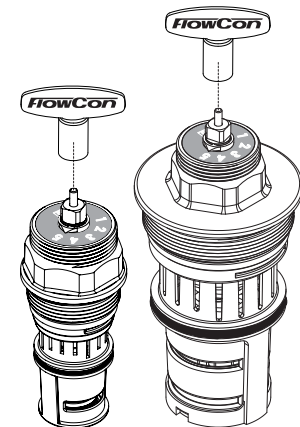

Use the special designed key (FlowCon part no. ACC0001) for micrometer setting.

Accuracy: Greatest of either ±10% of controlled flow rate or ±5% of maximum flow rate.

## GENERAL SPECIFICATIONS

### 1. PRESSURE INDEPENDENT DYNAMIC CONTROL VALVE FLOWCON GREEN

- 1.1. Contractor shall install the pressure independent dynamic control valves where indicated in drawings.
- 1.2. Valve shall be an electronic, dynamic, modulating, 2-way, pressure independent control device.
- 1.3. Pressure independent dynamic control valve shall accurately control flow, independent of system pressure fluctuation.
- 1.4. Maximum flow setting shall be adjustable to 41 different settings within the range of the valve size.

### 2. VALVE ACTUATOR

#### 2.a. FlowCon FT actuators

- 2.a.1. Valve actuator housing shall be rated to IP54, including up-side-down mounting.
- 2.a.2. Actuator shall be driven by 24V or 230V AC, and shall depending on actuator choice accept 0-10V DC or ON/OFF control signal.
- 2.a.3. Actuator shall use full stroke and provide full authority.
- 2.a.4. Actuator shall have visible indication of stroke position.
- 2.a.5. Failsafe function shall be available on all version.

OR...

#### 2.b. FlowCon FN actuators

- 2.b.1. Valve actuator housing shall be rated to IP54.
- 2.b.2. Actuator shall be driven by 24V AC/DC or 110V/230V AC, and shall depending on actuator choice accept 0(2)-10V DC, 3-point floating or 2-position control signal.
- 2.b.3. Actuator shall use full stroke and provide full authority.
- 2.b.4. Actuator shall have visible indication of stroke position.
- 2.b.5. Feedback signal 0(2)-10V DC to the control system shall be standard on modulating version.
- 2.b.6. Optional failsafe function shall be available on 24V AC/DC versions.
- 2.b.7. Optional auto stroke function shall be available on modulating version.
- 2.b.8. Manual override shall be possible without use of tools.

### 3. VALVE HOUSING

#### 3.a. FlowCon A

- 3.a.1. Valve housing shall consist of forged brass ASTM CuZn40Pb2, rated at no less than 2500 kPa static pressure at +120°C.

OR...

#### 3.b. FlowCon AB

- 3.b.1. Valve housing shall consist of forged brass ASTM CuZn40Pb2, rated at no less than 2500 kPa static pressure at +120°C.
- 3.b.2. Pressure/temperature test plugs for verifying accuracy of flow performance shall be available for all valve sizes.

OR...

#### 3.c. FlowCon ABV

- 3.c.1. Valve housing shall consist of forged brass ASTM CuZn40Pb2, rated at no less than 2500 kPa static pressure at +120°C.
- 3.c.2. Valve ball shall consist of chemically nickel plated brass (ASTM CuZn40Pb2).
- 3.c.3. Pressure/temperature test plugs for verifying accuracy of flow performance shall be available for all valve sizes.

### 4. FLOW REGULATION UNIT

- 4.1. Flow regulation unit shall consist of glass-reinforced PSU/POM/PPS with an EPDM diaphragm (20mm insert) or a hydrogenated acrylonitrile-butadiene-rubber diaphragm (40mm insert).
- 4.2. Flow regulation unit shall be readily accessible, for change-out or maintenance. Flow regulation unit shall be adjustable with the valve in-line and the system in operation.
- 4.3. Flow regulation unit shall be externally adjustable to 1 of 41 different flow rates without limiting the stroke length; shall be available in 2 different kPaD operational ranges for DN15/20/25 and 1 kPaD operational ranges for DN25/32/40; minimum range shall be capable of being activated by minimum 16 kPaD. Further, the flow regulation unit shall be capable of controlling the flow within  $\pm 10\%$  of rated flow or  $\pm 5\%$  of maximum flow.

## APPLICATION AND SCHEMATIC EXAMPLE

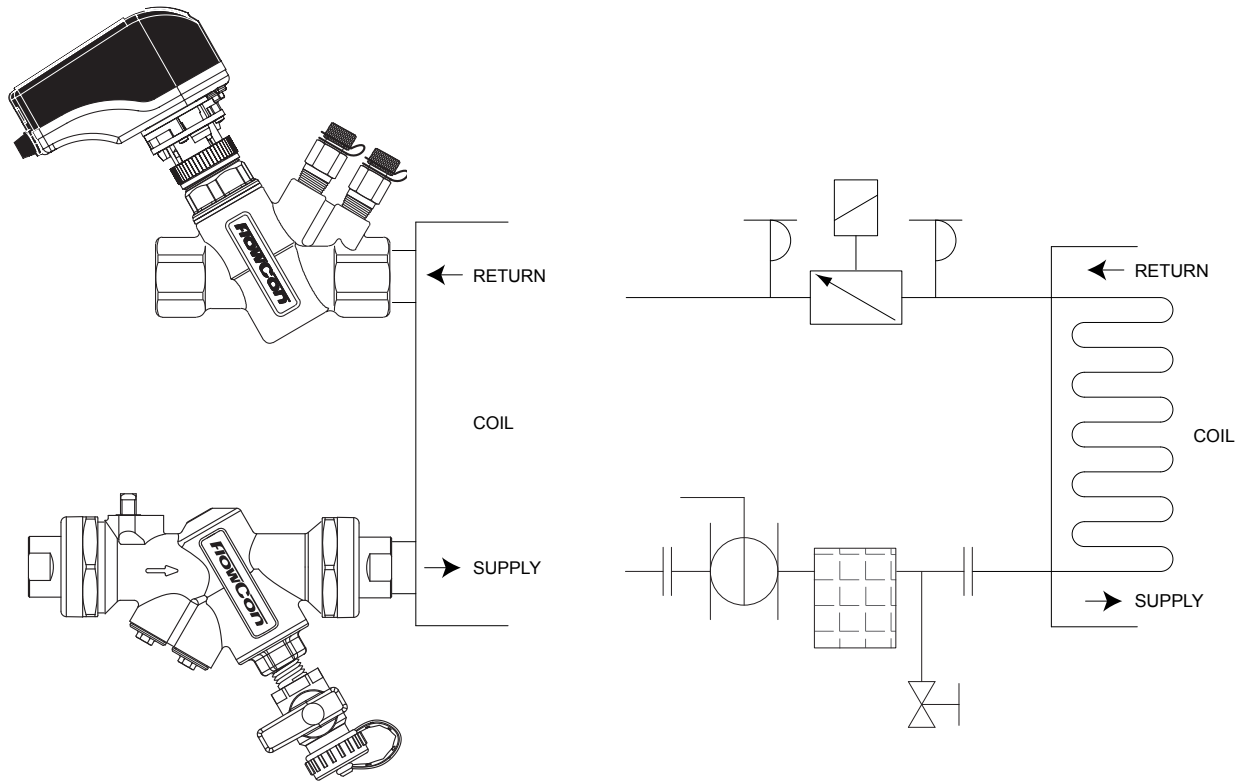

## UPDATES

For latest updates please see [www.flowcon.com](http://www.flowcon.com)

FlowCon International can accept no responsibility for possible errors in any printed material.  
All rights reserved.

# FlowCon Green.3



*100% Authority  
Pressure Independent Control Valve*

# FlowCon Green.3

## Pressure Independent Control Valve



The FlowCon Green.3 valve is a modern Pressure Independent Control Valve (PICV) meeting today's HVAC requirements of reducing the building operational costs without increasing the initial installation costs. This Green.3 valve is - given the precise flow control capabilities in combination with the low differential pressure required to operate the valve - an essential partner in the strive to reduce HVAC operational cost and thereby reduce the energy consumption and CO<sub>2</sub> emission.

The valve includes an innovative self-adjustment feature allowing continuous mechanical self-balancing in all valve positions. This ensures that each thermal unit controlled by the Green.3 valve is always supplied with the exact flow required for the specific system condition. The valve are furthermore constructed in such way that the valve stroke are identical regardless which of the 41 available pre-set values that are selected.

The valve is designed to facilitate large fan coils, smaller air handling units, smaller heat exchangers or equivalent, but it is generally the optimal choice in all applications where efficient distribution of water - with focus on system pressure drop - are required. The low pressure drop and feedback options make the valve ideal for Green Buildings also.

### Valve Choice

The FlowCon Green.3 valves are available in 2 versions:

- 40mm female/female threaded connection
- 50mm female/female threaded connection

### 100% Valve Authority

The FlowCon Green.3 is a true Pressure Independent Control Valve holding 100% authority at all times. The valve instantaneously self-balance at all points of operation, even when there is variance in pressure differential.

**100% Authority - Pressure Independent**

As long as the pressure differential across the valve is within the operating range, the Kv of the valve is variable and continuously regulated mechanically to keep the control valve in constant authority. The FlowCon Green.3 valve will in other words always utilize full stroke of the spindle offering 100% authority for any of its 41 maximum flow settings and any flow below requested by the building controls through the valve actuator.

### Features and Benefits

- **3-in-1 combi valve**, modulating control valve, dynamic flow limiter and differential pressure control valve in one body.
- **Differential pressure independent**.
- **Full stroke modulation** at any design flow.
- **100% authority** for any of the valves flow setting.
- **Automatic system balancing**, the correct flow rate for each circuit is achieved automatically.
- **Dynamic balancing**, the correct flow rate is maintained as each valve continuously compensates for pressure fluctuations in the system.
- **Field adjustable**, flow rate can be changed on demand to 41 predefined flow rates without removing the valve from the pipe works.
- **Elimination of branch or "partner" balancing valves** resulting in fewer total valves used in each project.
- **A Compact one-unit PICV** (housing and regulator is combined).
- **Accuracy**: Greatest of either  $\pm 10\%$  of controlled flow rate or  $\pm 5\%$  of maximum flow rate.
- **Up to 41 different flow curves** in one and the same insert.
- **Choice of actuator** 0(2)-10V modulating, 3-point floating or 2-position - all actuators features position indicator, manual overwrite and feedback signals for BMS monitoring.
- **Pressure/temperature measurement plugs** for verifying operating differential pressure or checking  $\Delta T$  across the coil.
- **Stepless adjustment**.



FlowCon Green.3			Setting	
DN40-50 , 1 1/2"-2"				
16-400 kPad · 2.3-58 psid				
Nominal flow rate	l/sec	l/hr	GPM	
	0.528	1900	8.36	1.0
	0.633	2278	10.0	1.1
	0.738	2655	11.7	1.2
	0.843	3033	13.3	1.3
	0.947	3410	15.0	1.4
	1.05	3787	16.7	1.5
	1.16	4163	18.3	1.6
	1.26	4537	20.0	1.7
	1.36	4909	21.6	1.8
	1.47	5279	23.2	1.9
	1.57	5646	24.8	2.0
	1.67	6011	26.4	2.1
	1.77	6372	28.0	2.2
	1.87	6730	29.6	2.3
	1.97	7083	31.2	2.4
	2.06	7432	32.7	2.5
	2.16	7776	34.2	2.6
	2.25	8115	35.7	2.7
	2.35	8449	37.2	2.8
	2.44	8777	38.6	2.9
	2.53	9098	40.0	3.0
	2.61	9413	41.4	3.1
	2.70	9721	42.8	3.2
2.78	10021	44.1	3.3	
2.86	10314	45.4	3.4	
2.94	10599	46.6	3.5	
3.02	10875	47.8	3.6	
3.10	11142	49.0	3.7	
3.17	11400	50.2	3.8	
3.24	11649	51.3	3.9	
3.30	11888	52.3	4.0	
3.37	12116	53.3	4.1	
3.43	12334	54.3	4.2	
3.48	12540	55.2	4.3	
3.54	12735	56.0	4.4	
3.59	12919	56.8	4.5	
3.64	13090	57.6	4.6	
3.68	13249	58.3	4.7	
3.72	13395	58.9	4.8	
3.76	13527	59.5	4.9	
3.79	13647	60.0	5.0	

### Principle of Operation

On closer examination of the inner workings of the FlowCon Green, the function is best described as 2 valves in 1. The second valve (V2) regulates the pressure differential across the first valve (V1) by means of a rolling diaphragm element counteracted by a spring. The first valve is a calibrated variable orifice device adjusted by the actuator (similar to a standard modulating control valve).

The diaphragm reacts to the system and regulates the pressure differential across the actuated control valve orifice to maintain its flow rate.

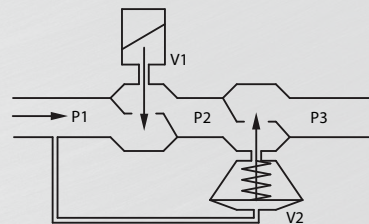

When pre-setting the maximum flow rate, the inlet orifice is changed in size sideways which does not interfere with the length of the stroke. When modulating, the orifice areas are affected by the actuator using the full stroke which results in the fact that the orifice area is changed in size in a vertical movement.

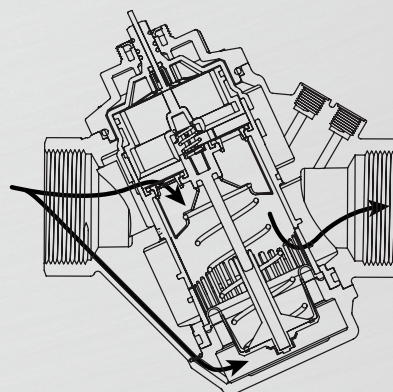

Accuracy: Greatest of either ±10% of controlled flow rate or ±5% of maximum flow rate.

**Hydronic Balance**

The valve can be pre-set to limit the maximum flow rate through the valve, without restricting the valve stroke. Consequently, hydronic balance is achieved automatically without usage of additional balancing valves.

**Pre-setting the Maximum Flow Rate**

The valve is adjusted to a maximum flow rate limit by setting the scale located on the top of the FlowCon Green.3 valve. The setting indicates one of 41 possible predefined maximum flow rates from 0.528-3.79 l/sec, but since the setting is step less any flow rate in between will be obtainable. The setting is done by means of a special FlowCon key. With the actuator mounted, the pre-setting is "sealed" to avoid tampering. Hereafter, the FlowCon Green.3 valve will eliminate any flow above the design flow.

For re-adjustment, simply disconnect power from the actuator and re-move the actuator from the insert. Then dial in the new required maximum flow and re-apply the actuator and connect power again.

For further information please see the installation and operation instruction manual.

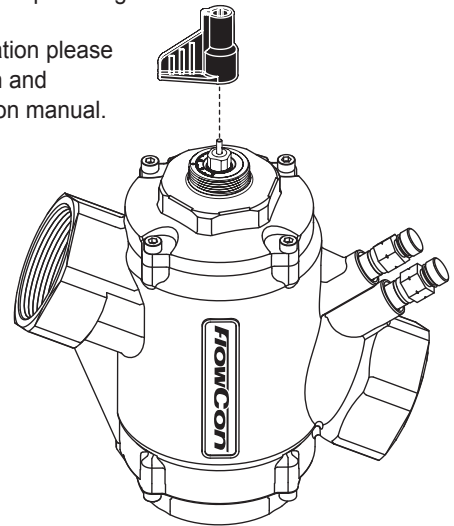

**Technical Data**

For further information and part number selection please see FlowCon tech note.

For latest updates please see [www.flowcon.com](http://www.flowcon.com).

		FlowCon Green.3
Static Pressure	(kPa)	2500
	(psi)	360
Temperature Rating (media / ambient)	(°C)	-20 to +120 / +2 to +50
	(°F)	-4 to +248 / +36 to +122
Pressure Drop Data	NOTE: For pump head calculations, add the minimum pressure differential for the index circuit to the other components pressure losses (i.e. valves, coil, etc.)	
Complete Unit	(Kvs-value) (m³/hr)	34.1
	(Cvs-value) (GPM)	39.6
Pressure Differential	(kPaD)	16-400
	(psid)	2.3-58
Flow Rate	(l/sec)	0.528-3.79
	(GPM)	8.36-60.0



A Griswold Controls LLC./FlowCon International Company

[www.flowcon.com](http://www.flowcon.com)

D E N M A R K . D U B A I . U S A . S I N G A P O R E

# FlowCon Green.3 - 40-50mm

*Pressure Independent Control Valves*



## SPECIFICATIONS

Static pressure:	2500 kPa / 360 psi
Ambient temperature:	+2°C to +50°C / +36°F to +122°F
Media temperature <sup>1</sup> :	-20°C to +120°C / -4°F to +248°F
Material:	
- Flow regulation unit (internal):	Glass-reinforced PSU/PPS/POM
- Metal components (internal):	Stainless steel
- O-rings and seats:	EPDM
- Diaphragm:	Hydrogenated acrylonitrile-butadiene-rubber
- Housing and covers:	Forged brass ASTM CuZn40Pb2
End connections <sup>2</sup> :	ISO or NPT
Maximum close off pressure:	600 kPaD / 87 psid
Maximum operational $\Delta P$ :	400 kPaD / 58 psid
Shut-off leakage:	ANSI / FCI 70-2 2006 / IEC 60534-4 - Class IV
Flow rate range:	0.528-3.79 l/sec / 8.36-60.0 GPM

Note 1: Stated temperature rating is defined due to no external condensation.  
Note 2: NPT only available ex. US-factory.

## SPECIFICATIONS (...continued)

### FlowCon Actuators:

FlowCon Actuator <sup>3</sup>	FH.0.2	FH.0.4	FH.1.2	FH.1.4
Supply voltage	24V AC/DC ±10%, 50/60 Hz			
Type	Electrical, Bi-directional synchronous motor			
Power consumption	7VA		9VA	
Control signal	Analog 0(2)-10V DC	Digital (2-position / 3-point floating)	Analog 0(2)-10V DC	Digital (2-position / 3-point floating)
Feedback	Yes, 0(2)-10V DC	No	Yes, 0(2)-10V DC	No
Failsafe function	No	No	Yes	Yes
Auto stroke	Yes	No	Yes	No
Operation time	50 Hz: 28 sec/mm			
Ambient temperature	+2°C to +50°C			
Humidity rating	<95% no condensation			
Protection	IP54, class II			
Cable	Fixed, 4 wires 22 AWG halogen free cable, 1 meter	Fixed, 3 wires 22 AWG halogen free cable, 1 meter	Fixed, 4 wires 22 AWG halogen free cable, 1 meter	Fixed, 4 wires 22 AWG halogen free cable, 1 meter
Closing point adjustment	During operation the actuator will self-adjust according to the closing point of the valve			
Weight	0.25 kg		0.30 kg	

Note 3: FlowCon warranty is voided using other actuators than supplied by FlowCon International.

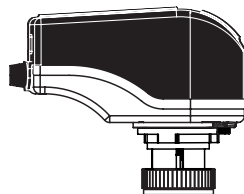

FlowCon FH.0.X

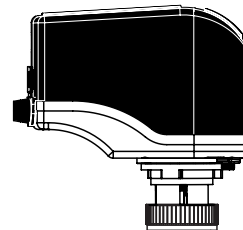

FlowCon FH.1.X

## DIMENSIONS AND WEIGHTS (NOMINAL) (measured in mm unless noted)

Model no.	Valve model	Valve size	L	H1	H2 FH.0.X actuator	H3 FH.1.X actuator	Weight <sup>4</sup> (kgs.)	Kvs <sup>5</sup> (m <sup>3</sup> /hr)
G.3.XX.40.X.X	Green.3	DN40 F/F	191.0	100.2	192.2	207.2	4.6	34.1
G.3.XX.50.X.X		DN50 F/F					4.2	

Note 4: Weight does not include end connections or actuator.

Note 5: For complete unit based on min. DP.

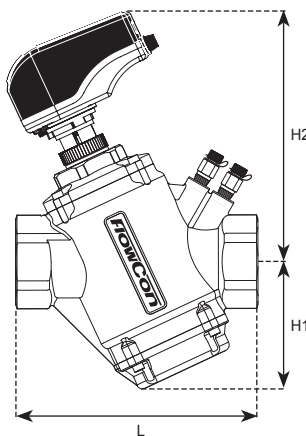

FlowCon Green DN40/50  
with FlowCon FH.0.X actuator

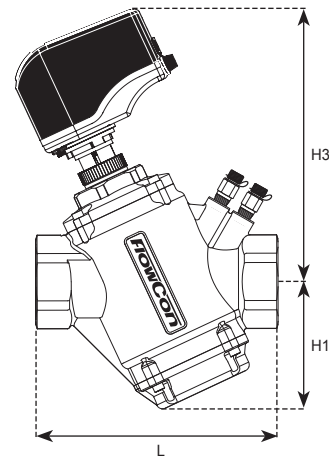

FlowCon Green DN40/50  
with FlowCon FH.1.X actuator

## MODEL NUMBER SELECTION

G.3 .

Insert type of actuator:

**52**=FH.0.2 **54**=FH.0.4 **62**=FH.1.2 **64**=FH.1.4

Insert size of body:

**40**=DN40 F/F **50**=DN50 F/F

Insert p/t plug requirements:

**B**=pressure/temperature plugs **P**=taps plugged - leave blank if no p/t plugs required

Insert connections standard:

**I**=ISO **N**=NPT<sup>6</sup>

Example: G.3.52.40.B.I=40mm FlowCon Green with a 24V electrically modulating actuator, p/t plugs and ISO female-female threaded.

Note 6: NPT only available ex. US-factory

## WIRING INSTRUCTION

### FlowCon FH.0.2 and FH.1.2

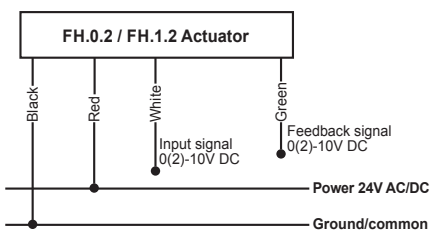

### FlowCon FH.0.4

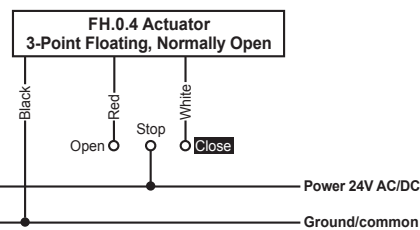
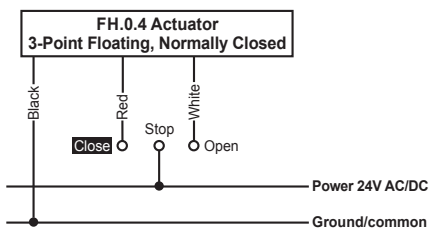
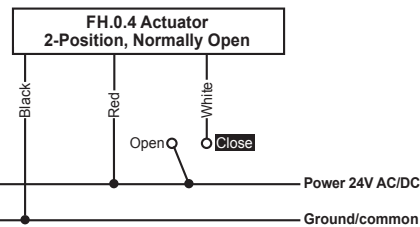
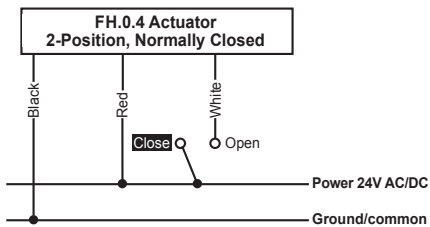

### FlowCon FH.1.4

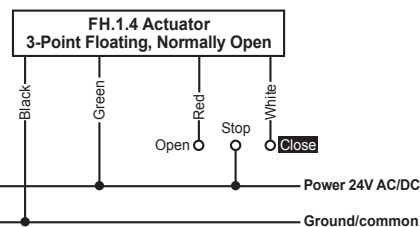
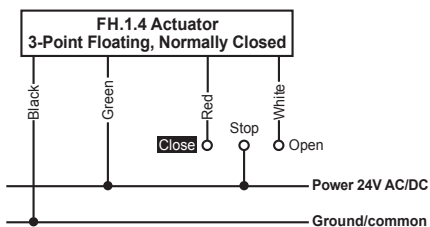
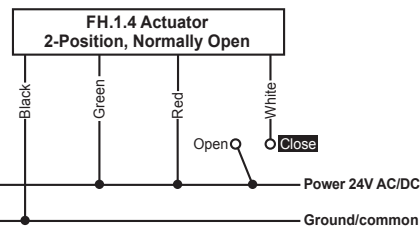
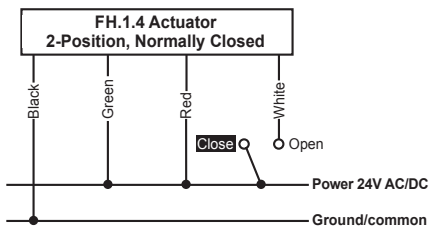

## DESCRIPTION

The FlowCon Green serie is pressure independent control valves that are two-way, modulating to accept digital or analog input signals. The valves accept 0(2)-10V, 3-point floating or ON/OFF input signals. Each valve has an adjustable maximum flow rate setting maintaining a full stroke to enable flow limitation and balancing to the coil or zone that the valve is controlling.

For use in fan-coil units, air-handling units, VAV applications and cooling ceilings for activation of the heating or cooling.

## MAXIMUM FLOW RATE LIMITATION SETTINGS

FlowCon Green.3				Setting
16-400 kPad · 2.3-58 psid				
Nominal flow rate	l/sec	l/hr	GPM	
	0.528	1900	8.36	1.0
	0.633	2278	10.0	1.1
	0.738	2655	11.7	1.2
	0.843	3033	13.3	1.3
	0.947	3410	15.0	1.4
	1.05	3787	16.7	1.5
	1.16	4163	18.3	1.6
	1.26	4537	20.0	1.7
	1.36	4909	21.6	1.8
	1.47	5279	23.2	1.9
	1.57	5646	24.8	2.0
	1.67	6011	26.4	2.1
	1.77	6372	28.0	2.2
	1.87	6730	29.6	2.3
	1.97	7083	31.2	2.4
	2.06	7432	32.7	2.5
	2.16	7776	34.2	2.6
	2.25	8115	35.7	2.7
	2.35	8449	37.2	2.8
2.44	8777	38.6	2.9	
2.53	9098	40.0	3.0	
2.61	9413	41.4	3.1	
2.70	9721	42.8	3.2	
2.78	10021	44.1	3.3	
2.86	10314	45.4	3.4	
2.94	10599	46.6	3.5	
3.02	10875	47.8	3.6	
3.10	11142	49.0	3.7	
3.17	11400	50.2	3.8	
3.24	11649	51.3	3.9	
3.30	11888	52.3	4.0	
3.37	12116	53.3	4.1	
3.43	12334	54.3	4.2	
3.48	12540	55.2	4.3	
3.54	12735	56.0	4.4	
3.59	12919	56.8	4.5	
3.64	13090	57.6	4.6	
3.68	13249	58.3	4.7	
3.72	13395	58.9	4.8	
3.76	13527	59.5	4.9	
3.79	13647	60.0	5.0	

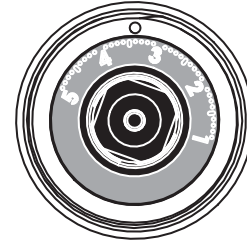

A micrometer setting of 3.4 as illustrated above corresponds to a maximum flow rate of:

2.86 l/sec

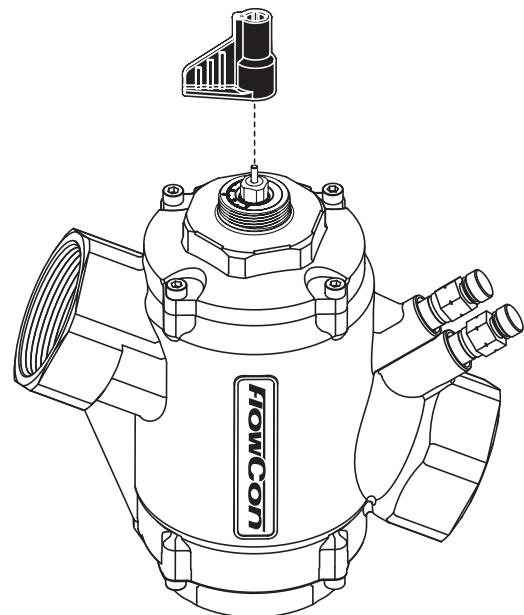

Use the special designed key (FlowCon part no. ACC0007) for micrometer setting.

Accuracy: Greatest of either  $\pm 10\%$  of controlled flow rate or  $\pm 5\%$  of maximum flow rate.

## GENERAL SPECIFICATIONS

### 1. PRESSURE INDEPENDENT DYNAMIC CONTROL VALVE - FLOWCON GREEN.3

- 1.1. Contractor shall install the pressure independent dynamic control valves where indicated in drawings.
- 1.2. Valve shall be an electronic, dynamic, modulating, 2-way, pressure independent control device.
- 1.3. Pressure independent dynamic control valve shall accurately control flow, independent of system pressure fluctuation.
- 1.4. Maximum flow setting shall be adjustable to 41 different settings within the range of the valve size.

### 2. VALVE ACTUATOR - FLOWCON FH

- 2.1. Valve actuator housing shall be rated to IP54.
- 2.2. Actuator shall be driven by 24V AC/DC and shall depending on actuator choice accept 0(2)-10V DC, 3-point floating or 2-position control signal.
- 2.3. Actuator shall use full stroke and provide full authority.
- 2.4. Actuator shall have visible indication of stroke position.
- 2.5. Feedback signal 0(2)-10V DC to the control system shall be standard on modulating version.
- 2.6. Optional failsafe function shall be available on 24V AC/DC versions.
- 2.7. Auto stroke function shall be available on modulating version.
- 2.8. Manual override shall be possible without use of tools.

### 3. VALVE HOUSING - FLOWCON GREEN.3

Valve housing DN40-DN50 female-female shall consist of forged brass ASTM CuZn40Pb2, rated at no less than 2500 kPa static pressure at +120°C.

### 4. FLOW REGULATION UNIT

- 4.1. Flow regulation unit shall consist of glass-reinforced PPS, PSU and POM with HNBR diaphragm and EPDM sealings.
- 4.2. Flow regulation unit shall be externally adjustable to 1 of 41 different flow rates; minimum range shall be capable of being activated by minimum 16 kPaD operation ranges; and shall be capable of controlling the flow within  $\pm 10\%$  of rated flow or  $\pm 5\%$  of maximum flow.

## APPLICATION AND SCHEMATIC EXAMPLE

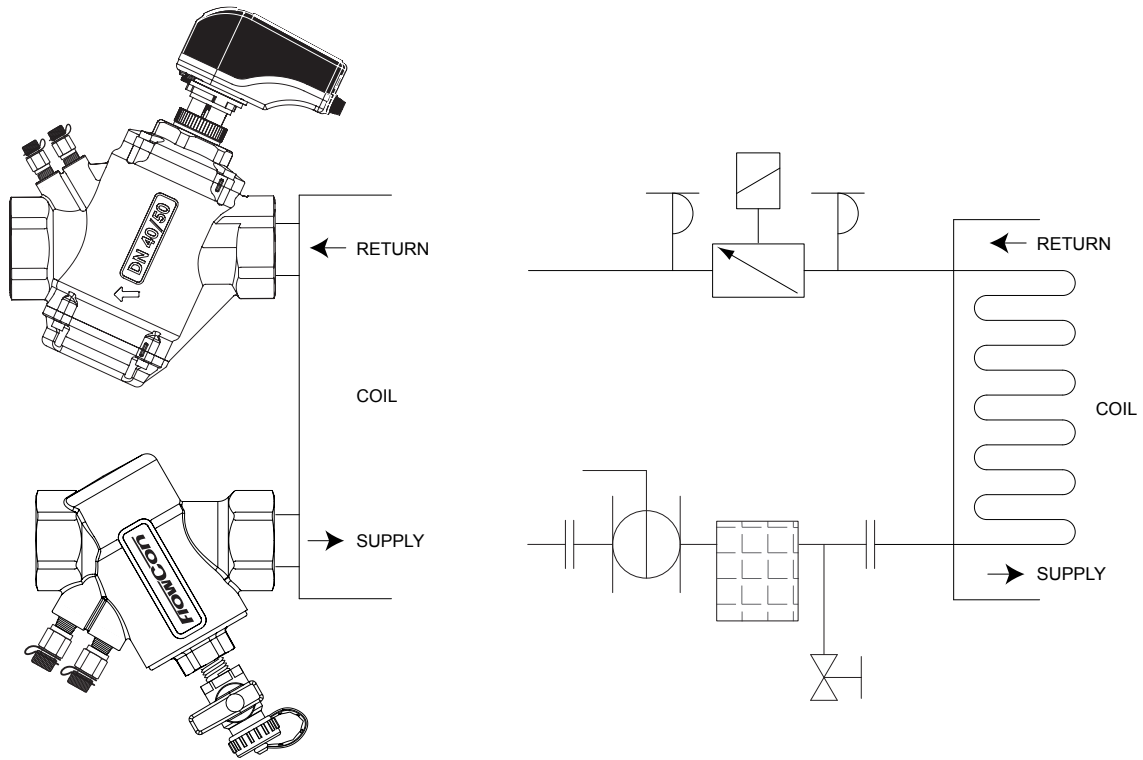

## UPDATES

For latest updates please see [www.flowcon.com](http://www.flowcon.com)

FlowCon International can accept no responsibility for possible errors in any printed material.  
All rights reserved.

# FlowCon SM

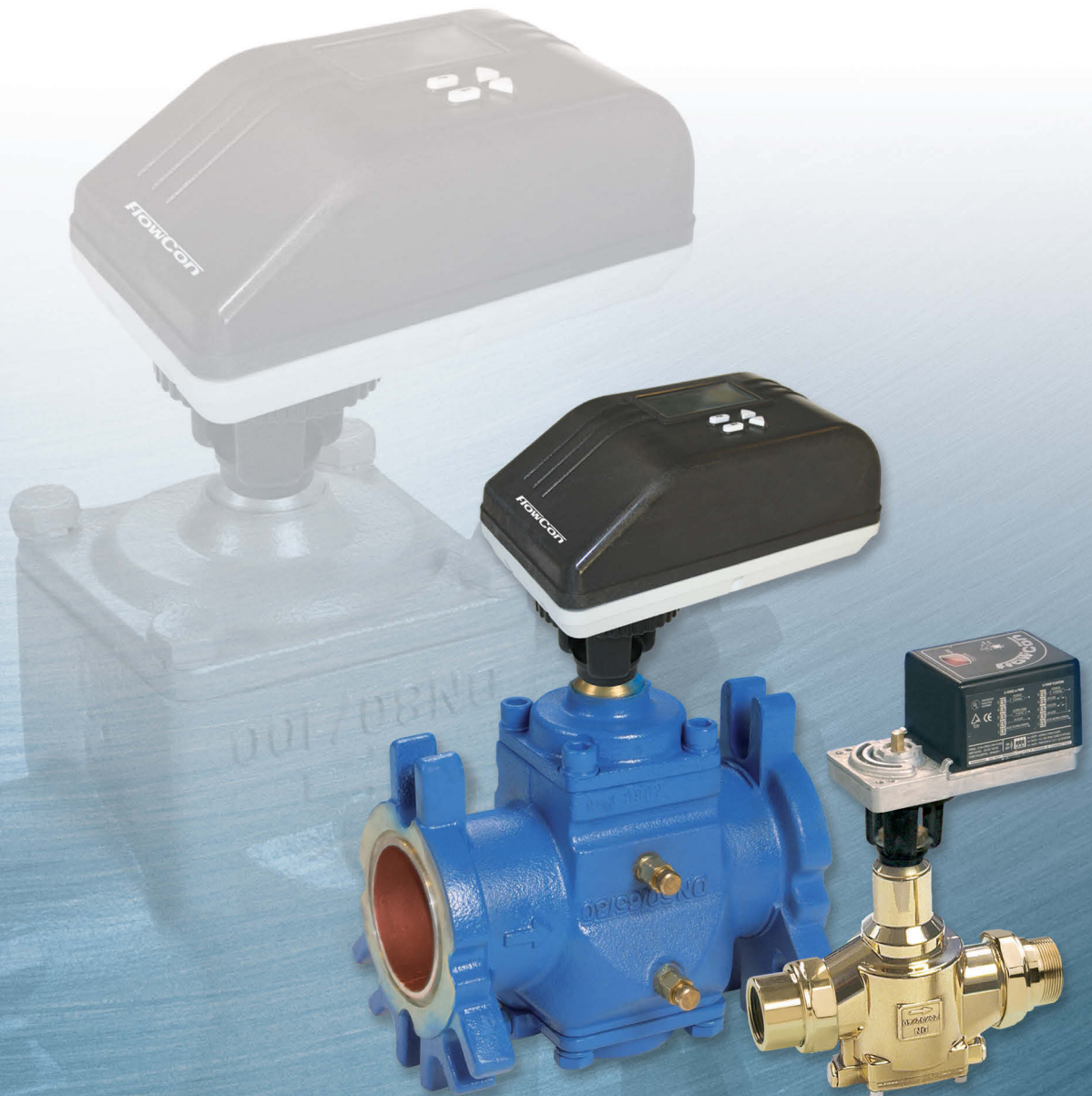

*The World's most Advanced Control Valves  
Now with New State-of-the-Art User Friendly Actuator*

# FlowCon SM

*Pressure Independent Control Valve (PICV)*

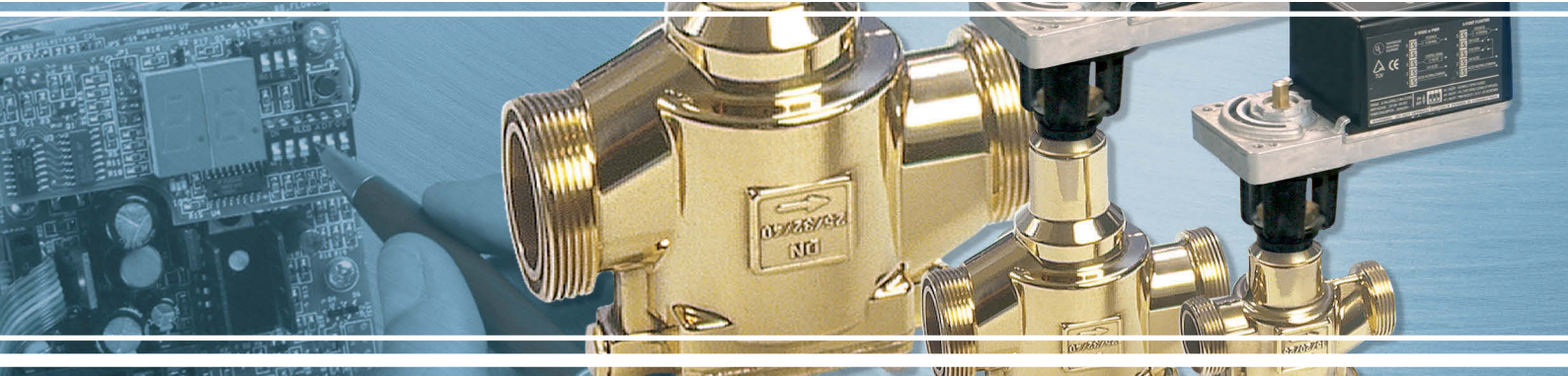

A common problem in hydronic systems is choosing the proper control valve while considering the requirements of acceptable authority. Along with this are the problems of determining the characteristics of the circuit necessary to assess the authority of the control valve.

Unstable and inaccurate regulation is often the consequence of over/under sizing a control valve. This is due to the fact that it is impossible to select a traditional control valve with a coefficient which optimally fits the given design parameters. Often the problem is exaggerated by pressure drop fluctuations across the control valve, which occur at varying loads in the system.

The FlowCon SM valve is a dynamic control valve which means the valve automatically keeps a constant differential pressure across the internal controlling orifice of the valve. Consequently, pressure drop fluctuations across the FlowCon SM will not affect the set flow through the valve. FlowCon SM can be set to limit the maximum design flow, which makes over-sizing control valves obsolete. Extensive calculations and assessments of the authority of the selected valve are eliminated. The dynamic flow characteristics keep the FlowCon SM in constant authority and automatically balanced, eliminating the requirement for a separate balancing valve in the circuit.

FlowCon SM dynamic temperature control valves are designed as an automatic temperature control for coils and AHUs; as a two-way regulation valve in HVAC installation such as radiator heating circuit or inventing heat systems; as a control valve for heat exchangers in heating systems to control floor heating circuits or other secondary heating circuits and as a control valve in hot water tank systems.

It is designed to control the rate of fluid flow to a specific terminal unit or coil. The FlowCon SM includes an innovative self adjustment feature which enables each valve continuously to self balance. This ensures delivery of precisely the flow rate required by each terminal unit, independent of pressure fluctuations in the hydronic system. Each FlowCon SM can also be adjusted to set an accurate maximum flow rate limit to each circuit.

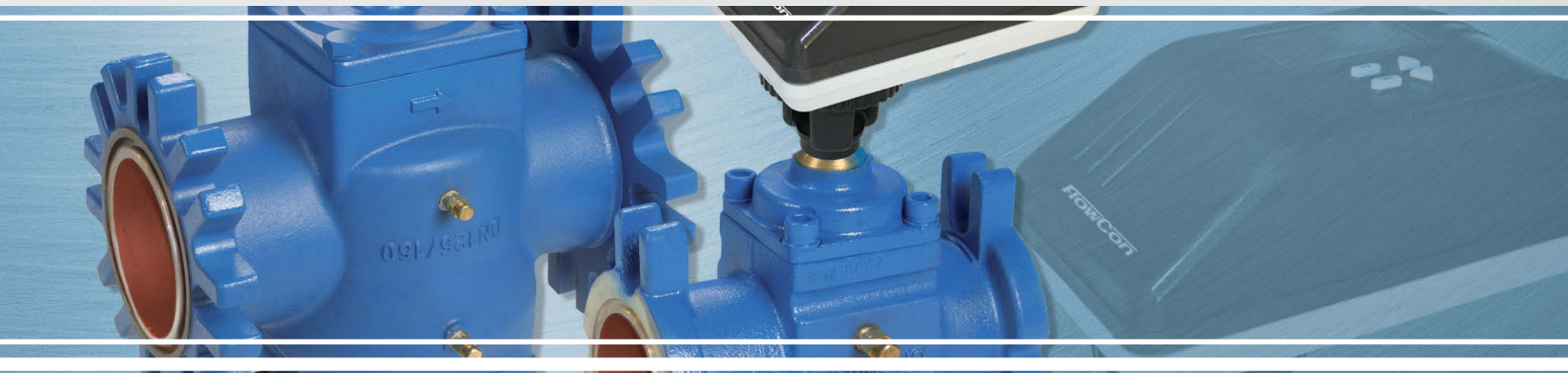

### Features and Benefits

- **Pressure independent flow control.**
- **Total valve authority.**
- **User friendly** touch panel on actuator for selection of flow, control input etc. (optional on SM DN15-40).
- **Save time and labor;** installation and adjustment of balancing valves are eliminated.
- **Kv sizing calculations and problems are eliminated;** each valve is adjustable to 51 different maximum flow rate settings.
- **Feedback signal** provides information of current valve position, which can be converted into flow rate.
- **Optional failsafe power storage feature** which opens or closes the valve in case external power supply fails.
- **Continuously displaying** flow rate - and scrolling other actuator information (optional on SM DN15-40).
- **Actuator** is suitable for electrical modulating, 3-point-floating or 2 position signals.
- **Pressure/temperature measurement plugs** for verifying operating pressure differential range or checking  $\Delta T$  across the coil.
- **Double union end or flange connection** for ease of installation.

### Principle of Operation

On closer examination of the inner workings of the FlowCon SM, the function is best described as 2 valves in 1. The first valve (V1) regulates the pressure differential across the second valve (V2) by means of a rolling diaphragm counteracted by a spring. The second valve is a calibrated variable orifice device adjusted by the actuator (similar to a standard modulating control valve). The diaphragm reacts to the system and regulates the pressure differential across the actuated control valve orifice to maintain its flow rate.

### System Layout Comparison and Valve Authority

The FlowCon SM is a 100% authority pressure independent flow control valve which instantaneously self-balance at all points of operation, even when there is variance in pressure differential. As long as the pressure differential across the valve is within the operating range, the Kv of the valve is variable, being continuously regulated to keep the control valve in constant authority.

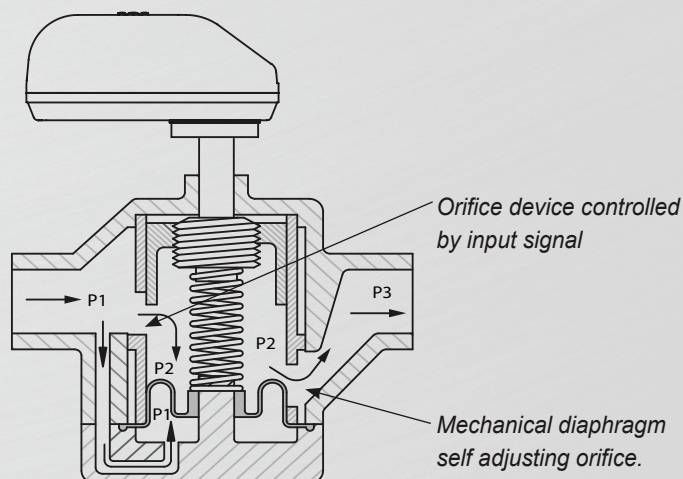
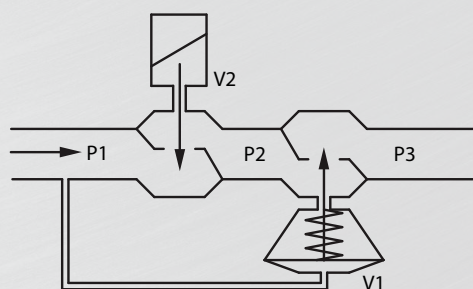

**Hydronic Balance**

The actuator can be pre-set to limit the working range of the valve which limits the maximum flow rate through the valve. Consequently, hydronic balance is achieved automatically without the use of additional balancing valves.

**User friendly programmable actuator**

All SM-valves can be fitted with the new state-of-the-art actuators which both in design and user-friendliness are unique. On the touch panel on the actuator all features are selected. It is possible to select 51 different flow rate maximums per valve. Both control input signal and feedback signal are also selected on the touch panel. Input signal can be modulating, 3-point-floating or 2 position and feedback signal can be "automatic", 0(2)-10V or 4-20mA.

The control signals i.e. input signals and feedback automatically adapt to the pre-set working range of the valve. This means that maximum signal is equal to the maximum pre-set design flow limit. The digital control system is allowed to work throughout the full range of the signal independent of the working range. Further, the valve can be selected to operate either in NC-mode (normally closed) so that the valve opens with an increasing signal or in NO-mode (normally open) so that it closes with an increasing signal.

**Failsafe**

The failsafe option will move the valve to safety position (standard is failsafe closed) during power failure utilized by a rechargeable battery.

**Technical Data**

For further information and part number selection please see FlowCon tech note.  
For latest updates please see [www.flowcon.com](http://www.flowcon.com).

	SM1 DN15/20/25	SM2 DN25/32/40	SM3 DN50/65/80			SM4 DN80/100			SM5 DN125/150		
Pressure Differential	(kPaD)	33-320	40-320	30-600	30-600	35-600	30-600	35-600	50-600	30-600	35-600
	(psid)	4.6-46	5.8-46	4.5-87	4.5-87	5.1-87	4.5-87	5.1-87	7.3-87	4.5-87	5.1-87
Flow Rate	(l/sec)	0.176-0.685	0.513-2.34	1.48-4.16	2.57-7.15	3.55-9.88	3.49-9.38	4.73-14.2	3.68-20.2	6.48-23.3	7.10-29.5
	(GPM)	2.79-10.9	8.14-37.1	23.4-66.0	40.7-113	56.3-157	55.4-149	75.0-225	58.3-320	103-369	113-468
Static Pressure	(kPa)	2500		4000							
	(psi)	360		580							
Temperature Rating	(°C)	-20 to +120 / -10 to +54									
	(media/ambient) (°F)	-4 to +248 / +14 to +131									

NOTE: For pump head calculations, add the minimum pressure differential for the index circuit to the other components pressure losses (i.e. valves, coil, etc.)



A Griswold Controls LLC./FlowCon International Company

[www.flowcon.com](http://www.flowcon.com)

D E N M A R K . D U B A I . U S A . S I N G A P O R E

# FlowCon SM 15-40mm

## Dynamic Self Balancing Control Valve



### SPECIFICATIONS

Pressure rating:	2500 kPa / 360 psi
Temperature rating, media:	-20°C to +120°C / -4°F to +248°F
Temperature rating, ambient:	-10°C to +50°C / +14°F to +122°F
Material:	
- Diaphragm:	Hydrogenated acrylonitrile-butadiene-rubber
- Body:	Forged brass ASTM CuZn40Pb2
- Union end connections:	Brass alloy ISO or NPT
- O-rings:	EPDM
- Internal metal components:	Stainless steel
Body tappings:	1/4" NPT
Maximum close off pressure:	600 kPa / 87 psi
Maximum operational ΔP:	320 kPaD / 46 psid
Flow rate range:	0.176-2.34 l/sec / 2.78-37.1 GPM

## DIMENSIONS AND WEIGHTS (NOMINAL) (measured in mm unless noted)

Model no.	Valve size	L	H1 with actuator SM.0.0.0.1	H2	H3 with actuator SM.0.0.0.3/4/5/6	End connections C <sup>1</sup>			Weight <sup>2</sup> (kgs.) with actuator SM.0.0.0.1 (w/o end conn.)	Weight <sup>2</sup> (kgs.) with actuator SM.0.0.0.3/4/5/6 (w/o end conn.)
						ISO Female	ISO Male	Sweat		
SM.1.1	15	108	182	59	185	22	24	20	2.6	2.9
	20					22	25	20		
	25					-	39	22		
SM.2.1	25	149	232	63	235	35	40	34	4.3	4.6
	32					33	40	34		
	40					33	42	-		

Note 1: Add end connection length to body length.  
 Note 2: Weight includes valve and actuators.

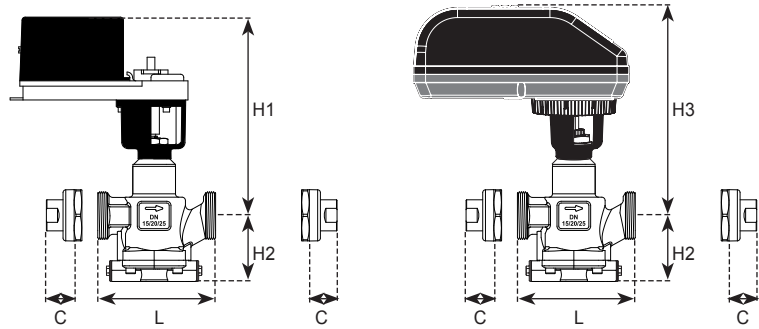

## FLOW RATE TABLE

Model no.	Valve size		Control range		Minimum setting			Maximum setting			Shut-off leakage
	mm	inch	kPaD	psid	l/sec	l/hr	GPM	l/sec	l/hr	GPM	
SM.1.1	15	1/2"	32-320	4.6-46	0.176	634	2.78	0.685	2470	10.9	Leakage<0.05% of Kvs Kvs=4.1 m³/hr
	20	3/4"									
	25	1"									
SM.2.1	25	1"	40-320	5.8-46	0.513	1850	8.13	2.34	8420	37.1	Leakage<0.05% of Kvs Kvs=12.6 m³/hr
	32	1 1/4"									
	40	1 1/2"									

## CONTROL CURVE AT MAXIMUM PRE-SETTING<sup>3</sup>

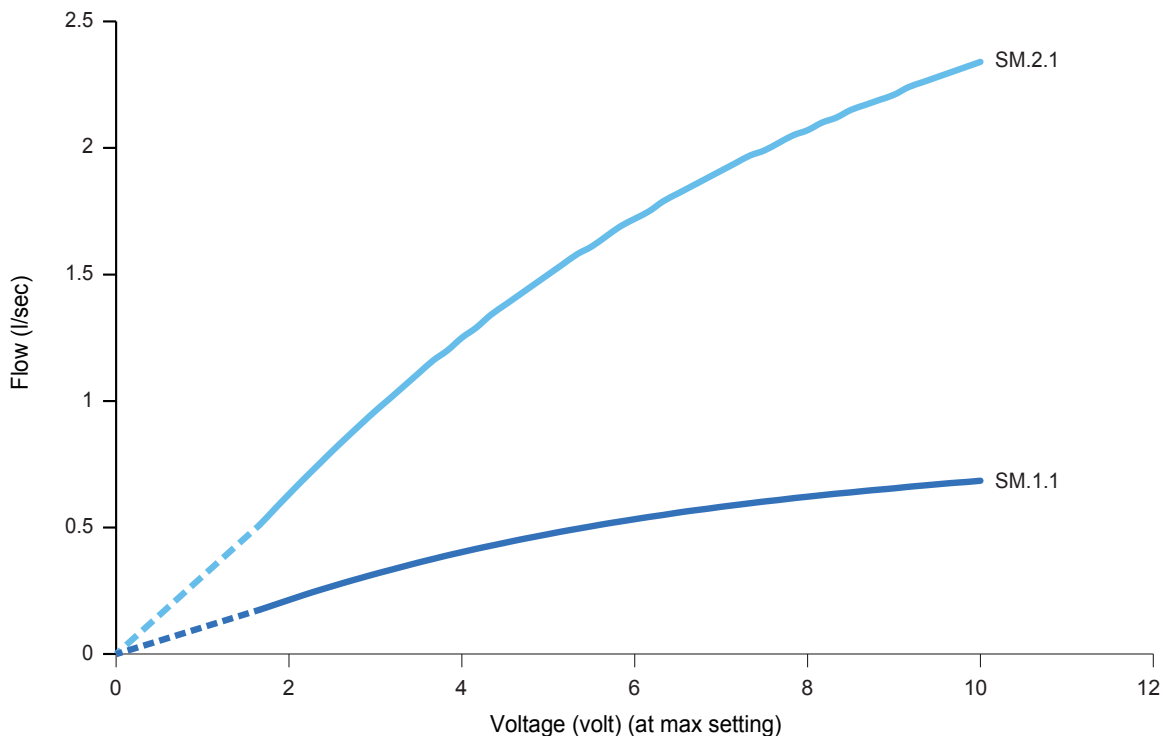

Note 3: Above curves show the control curve of the valves in maximum allowed pre-setting condition and may vary if lower pre-settings are selected. The valves will always have 1.000 positions between the pre-set flow value and 0V if control range is selected to 0-10V.

## MODEL NUMBER SELECTION

**SM . . . 1 . . . . .**

Insert body size:  
**1**=15-25mm, 1/2"-1"    **2**=25-40mm, 1"-1 1/2"

Insert dP control range:  
**1**=standard

Insert p/t plug requirements:  
**B**=pressure/temperature plugs    **P**=taps plugged (standard)

Insert actuator selection:  
**1**=brush/basic (standard, SM.0.0.0.1)    **3**=display (SM.0.0.0.3)    **4**=display and failsafe (SM.0.0.0.4)  
**5**=display and BACnet (SM.0.0.0.5)    **6**=display, BACnet and failsafe (SM.0.0.0.6)

Insert inlet x outlet union end connections:

Body size	Female threaded	Male treaded	Sweat
15-25mm, 1/2"-1"	<b>E</b> =15mm=1/2" <b>F</b> =20mm=3/4"	<b>H</b> =15mm=1/2" <b>I</b> =20mm=3/4" <b>J</b> =25mm=1"	<b>K</b> =15mm <b>L</b> =18mm <b>M</b> =22mm
25-40mm, 1"-1 1/2"	<b>G</b> =25mm=1" <b>P</b> =32mm=1 1/4" <b>Q</b> =40mm=1 1/2"	<b>J</b> =25mm=1" <b>S</b> =32mm=1 1/4" <b>T</b> =40mm=1 1/2"	<b>N</b> =28mm <b>W</b> =35mm

Insert connections standard:  
**I**=ISO    **N**=NPT

Example: SM.2.1.B.1.Q.Q.I=SM 25-40mm body with p/t plugs, standard brush basic actuator and 40mm ISO female threaded end connections.

## ACTUATOR SPECIFICATIONS<sup>4</sup>

### FlowCon SM.0.0.0.1 actuator

Supply voltage:	24V AC or 30V DC
Power consumption:	20VA @ 26V AC
Frequency:	50/60 HZ
Control input:	2-10V DC, 4-20mA or 3-point floating
Feedback position output:	2-10V DC or 4-20mA
Turn time:	150 seconds (from closed to fully open valve)
Electrical connection:	15mm grommet connection
Direction of rotation:	Bi-directional
Humidity rating:	Fully coated electronic board
Housing material:	Aluminium
Housing insulation:	IP42



### FlowCon SM.0.0.0.3, SM.0.0.0.4, SM.0.0.0.5 (with BACnet) and SM.0.0.0.6 (with BACnet and failsafe) actuators

Supply voltage:	24V AC/DC
Power consumption:	12VA
Frequency:	50/60 HZ
Control input:	0-10V DC, 2-10V DC, 0-20mA, 4-20mA, 2-position or 3-point floating
Feedback position output:	Automatic match of control input, 0-10V DC, 2-10V DC or 4-20mA
Turn time:	190 seconds (from closed to fully open valve)
Electrical connection:	5 wires 22 AWG halogen free cable, 1 meter For BACnet versions another 3 wires 22 AWG halogen free cable, 1 meter
Direction of rotation:	Bi-directional
Humidity rating:	5 to 95% RH non condensing
Housing material:	UL94 V0-rated plastic
Housing insulation:	IP54 including up-side-down mounting
Programming:	External programming of all settings, interface of buttons and display
Calibration:	Automatic calibration at startup
Valve - actuator coupling:	Easy snap coupling
BACnet device profile:	BACnet Application Specific Controller (B-ASC) type server
BACnet protocol:	BACnet Master Slave/Token passing (MS/TP)
BACnet baud rates supported:	9600, 19200, 38400 and 76800
BACnet services (BIBBS) supported:	DS-RP-B, DS-WP-B, DM-DDB-B, DM-DOB-B and DM-DCC-B.

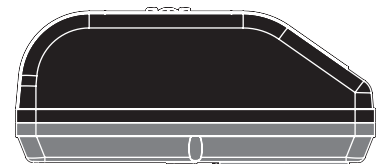

Note 4: FlowCon warranty is voided using other actuators than supplied or recommended by FlowCon International.

## FLOW RATE SETTING - VALVE SIZE DN15-DN40

Maximum Flow Rate <sup>5</sup>					
DN15-DN25 · 1/2"-1"			DN25-DN40 · 1"-1 1/2"		
32-320 kPaD · 4.6-46 psid			40-320 kPaD · 5.8-46 psid		
SM.1.1			SM.2.1		
l/sec	l/hr	GPM	l/sec	l/hr	GPM
0.176	633	2.78	0.513	1850	8.13
0.195	702	3.09	0.573	2060	9.08
0.214	770	3.39	0.632	2280	10.0
0.233	838	3.69	0.690	2480	10.9
0.251	902	3.97	0.746	2690	11.8
0.268	964	4.24	0.802	2890	12.7
0.285	1030	4.51	0.856	3080	13.6
0.301	1080	4.77	0.909	3270	14.4
0.317	1140	5.02	0.961	3460	15.2
0.332	1200	5.26	1.01	3640	16.0
0.347	1250	5.50	1.06	3820	16.8
0.362	1300	5.73	1.11	4000	17.6
0.376	1350	5.96	1.16	4170	18.3
0.390	1400	6.18	1.20	4330	19.1
0.403	1450	6.38	1.25	4500	19.8
0.416	1500	6.59	1.29	4660	20.5
0.428	1540	6.78	1.34	4810	21.2
0.440	1580	6.97	1.38	4970	21.9
0.452	1630	7.16	1.42	5120	22.5
0.463	1670	7.33	1.46	5260	23.2
0.474	1710	7.51	1.50	5400	23.8
0.485	1750	7.68	1.54	5540	24.4
0.495	1780	7.84	1.58	5680	25.0
0.505	1820	8.00	1.61	5810	25.6
0.515	1850	8.16	1.65	5940	26.2
0.524	1890	8.30	1.69	6070	26.7
0.533	1920	8.44	1.72	6190	27.3
0.542	1950	8.59	1.75	6310	27.8
0.550	1980	8.71	1.79	6430	28.3
0.559	2010	8.86	1.82	6550	28.8
0.567	2040	8.98	1.85	6660	29.3
0.574	2070	9.09	1.88	6770	29.8
0.582	2100	9.22	1.91	6870	30.3
0.589	2120	9.33	1.94	6980	30.7
0.596	2150	9.44	1.97	7080	31.2
0.603	2170	9.55	1.99	7180	31.6
0.609	2190	9.66	2.02	7280	32.0
0.616	2220	9.76	2.05	7370	32.5
0.622	2240	9.85	2.07	7460	32.9
0.628	2260	9.95	2.10	7550	33.3
0.634	2280	10.1	2.12	7640	33.6
0.639	2300	10.1	2.15	7730	34.0
0.645	2320	10.2	2.17	7810	34.4
0.650	2340	10.3	2.19	7890	34.8
0.655	2360	10.4	2.22	7970	35.1
0.661	2380	10.5	2.24	8050	35.5
0.667	2400	10.6	2.26	8130	35.8
0.671	2420	10.6	2.28	8200	36.1
0.676	2430	10.7	2.30	8280	36.4
0.680	2450	10.8	2.32	8350	36.8
0.685	2470	10.9	2.34	8420	37.1

Accuracy: Greatest of either ±5% of controlled flow rate or ±2% of maximum flow rate.

Note 5: Above values are related to maximum flow rate setting of the valve and thereby defining the flow through the valve at maximum control signal, normally 10V. Values above do not relate to control signals below 10V. All above values will have 1.000 positions between the pre-set flow value and 0V if control range is selected to 0-10V.

Maximum Flow Rate DIP Switch Settings						Stem Rotations From Closed
Used on SM.0.0.0.1						
1	2	3	4	5	6	Rotations
ON	ON	ON	ON	ON	ON	1.0
OFF	ON	ON	ON	ON	ON	1.1
ON	OFF	ON	ON	ON	ON	1.2
OFF	OFF	ON	ON	ON	ON	1.3
ON	ON	OFF	ON	ON	ON	1.4
OFF	ON	OFF	ON	ON	ON	1.5
ON	OFF	OFF	ON	ON	ON	1.6
OFF	OFF	OFF	ON	ON	ON	1.7
ON	ON	ON	OFF	ON	ON	1.8
OFF	ON	ON	OFF	ON	ON	1.9
ON	OFF	ON	OFF	ON	ON	2.0
OFF	OFF	ON	OFF	ON	ON	2.1
ON	ON	OFF	OFF	ON	ON	2.2
OFF	ON	OFF	OFF	ON	ON	2.3
ON	OFF	OFF	OFF	ON	ON	2.4
OFF	OFF	OFF	OFF	ON	ON	2.5
ON	ON	ON	ON	OFF	ON	2.6
OFF	ON	ON	ON	OFF	ON	2.7
ON	OFF	ON	ON	OFF	ON	2.8
OFF	OFF	ON	ON	OFF	ON	2.9
ON	ON	OFF	ON	OFF	ON	3.0
OFF	ON	OFF	ON	OFF	ON	3.1
ON	OFF	OFF	ON	OFF	ON	3.2
OFF	OFF	OFF	ON	OFF	ON	3.3
ON	ON	ON	OFF	OFF	ON	3.4
OFF	ON	ON	OFF	OFF	ON	3.5
ON	OFF	ON	OFF	OFF	ON	3.6
OFF	OFF	ON	OFF	OFF	ON	3.7
ON	ON	OFF	OFF	OFF	ON	3.8
OFF	ON	OFF	OFF	OFF	ON	3.9
ON	OFF	OFF	OFF	OFF	ON	4.0
OFF	OFF	OFF	OFF	OFF	ON	4.1
ON	ON	ON	ON	ON	OFF	4.2
OFF	ON	ON	ON	ON	OFF	4.3
ON	OFF	ON	ON	ON	OFF	4.4
OFF	OFF	ON	ON	ON	OFF	4.5
ON	ON	OFF	ON	ON	OFF	4.6
OFF	ON	OFF	ON	ON	OFF	4.7
ON	OFF	OFF	ON	ON	OFF	4.8
OFF	OFF	OFF	ON	ON	OFF	4.9
ON	ON	ON	OFF	ON	OFF	5.0
OFF	ON	ON	OFF	ON	OFF	5.1
ON	OFF	ON	OFF	ON	OFF	5.2
OFF	OFF	ON	OFF	ON	OFF	5.3
ON	ON	OFF	OFF	ON	OFF	5.4
OFF	ON	OFF	OFF	ON	OFF	5.5
ON	OFF	OFF	OFF	ON	OFF	5.6
OFF	OFF	OFF	OFF	ON	OFF	5.7
ON	ON	ON	ON	OFF	OFF	5.8
OFF	ON	ON	ON	OFF	OFF	5.9
ON	OFF	ON	ON	OFF	OFF	6.0

Accuracy: Greatest of either ±5% of controlled flow rate or ±2% of maximum flow rate.

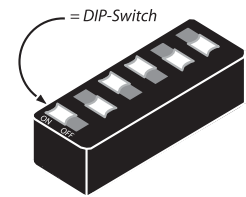

Example illustrated above:

**ON-OFF-ON-ON-OFF-OFF**

which gives a max flow of:

**SM.1.1** - 0.685 l/sec and

**SM.2.1** - 2.34 l/sec

(rotation 6.0).

## GENERAL DESCRIPTION

The SM Series are self balancing dynamic flow control valves that are pressure independent, two-way, modulating to accept digital or analog input signals. The valves accept 2-10V DC, 4-20mA or digital 3-point floating input signals. Each valve has an adjustable maximum flow rate setting to enable flow limitation and balancing to the coils or zones that the valves are controlling.

All SM actuators are microprocessor based with a self-calibrating feature.  
The valves are all designed for double union piping connection.  
They are available in two different valve bodies with end connections from 15mm-40mm.

## GENERAL SPECIFICATIONS

### 1. PRESSURE INDEPENDENT DYNAMIC CONTROL VALVES - FLOWCON SM

- 1.1. Contractor shall install pressure independent dynamic control valves where indicated in drawings.
- 1.2. Valve shall be an electronic, dynamic, modulating, 2-way pressure independent control device.
- 1.3. Pressure independent dynamic control valve shall accurately control flow, independent of system pressure fluctuation.
- 1.4. Maximum flow setting shall be adjustable to 51 different settings within the range of the valve size.

### 2.a. VALVE ACTUATOR / FLOWCON SM.0.0.0.1

- 2.a.1. Valve actuator housing shall be rated to IP42.
- 2.a.2. Actuator shall be driven by a 24V AC or 30V DC motor, and shall accept 2-10V DC, 4-20mA or 3-point floating electric signal and shall include resistor to facilitate any of these signals.
- 2.a.3. Actuator shall be capable of providing 4-20mA or 2-10V DC feedback signal to the control system.
- 2.a.4. External LED read-out of current valve position and maximum valve position setting shall be available.

OR...

### 2.b. VALVE ACTUATOR / FLOWCON SM.0.0.0.3, SM.0.0.0.4, SM.0.0.0.5 and SM.0.0.0.6

- 2.b.1. Valve and actuator coupling shall have snap couplings for fast mounting and demounting.
- 2.b.2. Actuator housing shall be rated to IP54 including up-side-down mounting.
- 2.b.3. Actuator shall be driven by a 24V AC/DC motor and shall accept 0-10V DC, 2-10V DC, 0-20mA, 4-20mA, 2-position or 3-point floating electric input signal.
- 2.b.4. Actuator shall be capable of providing same as input, 4-20mA, 0-10V DC or 2-10V DC feedback signal to the control system.
- 2.b.5. Automatic calibration of valve position shall be standard.
- 2.b.6. Actuator shall include display and buttons for external programming of all settings.
- 2.b.7. External display of current valve flow, maximum valve flow, input signal, feedback signal and operational direction shall be standard.
- 2.b.8. Optional fail safe system to power valve to either open (max. setting) or closed position from any position in case of power failure shall be available.
- 2.b.9. Optional BACnet connection for remote setting and control of actuator shall be available.

### 3. VALVE HOUSING

- 3.1. Valve housing shall consist of forged brass ASTM CuZn40Pb2, rated at no less than 2500 kPa static pressure and +120°C.
- 3.2. Valve housing shall be permanently marked to show direction of flow.
- 3.3. Valve housing shall be double union end constructed with a range of pipe connections available for the appropriate pipe size.
- 3.4. Optional dual pressure/temperature test plugs for verifying accuracy of flow performance shall be available for all valve sizes.

### 4. FLOW REGULATOR / AUTOMATIC BALANCING UNIT

- 4.1. Flow regulation unit shall be manufactured of stainless steel and hydrogenated acrylonitrile-butadiene-rubber and shall be capable of controlling flow within  $\pm 5\%$  rated flow rate or  $\pm 2\%$  of maximum flow rate.
- 4.2. Flow regulation unit shall be accessible for change-out maintenance.

## APPLICATION AND SCHEMATIC EXAMPLE

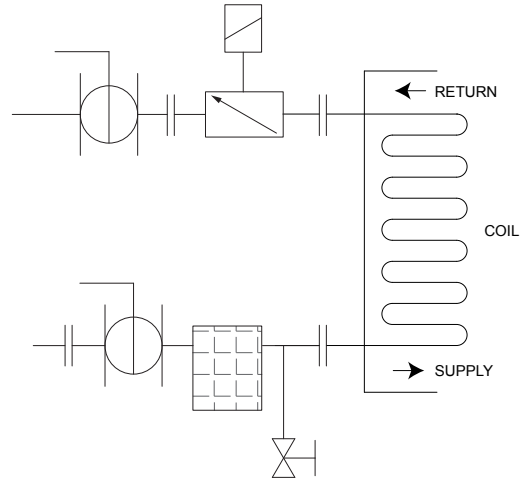
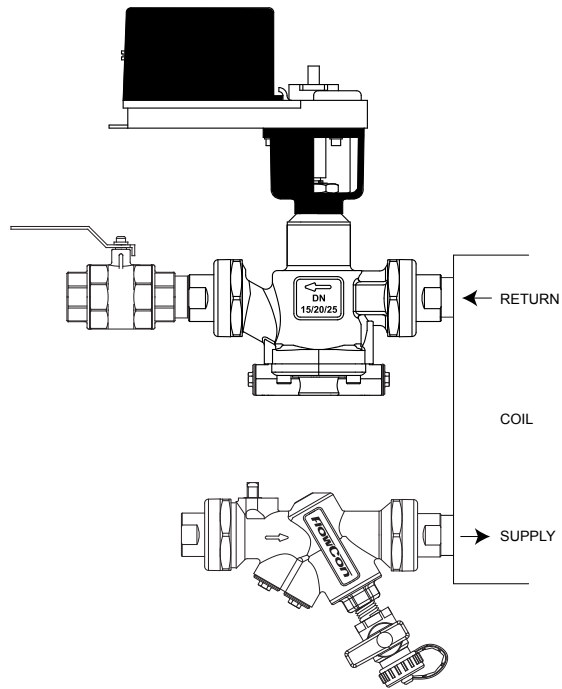

## UPDATES

**For latest updates please see [www.flowcon.com](http://www.flowcon.com)**

FlowCon International can accept no responsibility for possible errors in any printed material.  
All rights reserved.

# FlowCon SM 50-150mm

## Pressure Independent Control Valve



### SPECIFICATIONS

Pressure rating:	4000 kPa / 580 psi
Temperature rating, media:	-20°C to +120°C / -4°F to +248°F
Temperature rating, ambient:	-10°C to +50°C / +14°F to +122°F
Material:	
- Diaphragm:	Hydrogenated acrylonitrile-butadiene-rubber
- Body:	Ductile iron ASTM A395 Grade 60-40-18
- O-rings:	EPDM
- Internal metal components:	Stainless steel
End connection:	Universal flange connections which can be used with both ISO and ANSI Flanges and mounting kits are not supplied by FlowCon <sup>1</sup>
Body tappings:	1/4" ISO
Maximum close off pressure:	700 kPa / 100 psi
Maximum operational $\Delta P$ :	600 kPaD / 87 psid
Maximum allowable operating pressure:	1600 kPaD / 232 psid
Shut-off leakage:	ANSI / FCI 70-2 2006 / IEC 60534-4 - Class IV
Flow rate range:	1.48-29.5 l/sec / 23.4-468 GPM

Note 1: 2x16mm studs and 4x16mm bolts with nuts are supplied with SM.3.x.x.x.

## DIMENSIONS AND WEIGHTS (NOMINAL) (measured in mm unless noted)

Model no.	Valve size	L	H1	H2	Weight <sup>2</sup> (kgs.)
SM.3.X	50	224	252	95	15.0 <sup>3</sup>
	65				
	80				
SM.4.X	80	320	292	135	31.0
	100				32.0 (SM.4.3)
SM.5.X	125	422	343	180	61.0
	150				

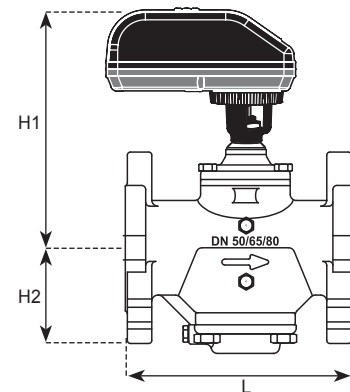

Note 2: Weight includes valve and actuator.  
 Note 3: Including studs, bolts and nuts provided with valve.

## MODEL NUMBER SELECTION<sup>4</sup>

Insert valve body size:  
**3**=50-80mm, 2"-3"    **4**=80-100mm, 3"-4"    **5**=125-150mm, 5"-6"

Insert dP control range:  
**0**=30-600 kPaD, 4.5-87 psid (SM.3 only)  
**1**=30-600 kPaD, 4.5-87 psid  
**2**=35-600 kPaD, 5.1-87 psid  
**3**=50-600 kPaD, 7.3-87 psid (SM.4 only)

Insert p/t plug requirements:  
**B**=p/t plugs (standard)

Insert actuator selection:  
**3**=display (SM.0.0.0.3)    **4**=display and failsafe (SM.0.0.0.4)    **5**=display and BACnet (SM.0.0.0.5)    **6**=display, BACnet and failsafe (SM.0.0.0.6)

Example: SM.3.1.B.4=SM 2"-3" body for 30-600 kPaD with p/t plugs and failsafe actuator.

Note 4: Model no. and pressure range are indicated on label affixed to body.

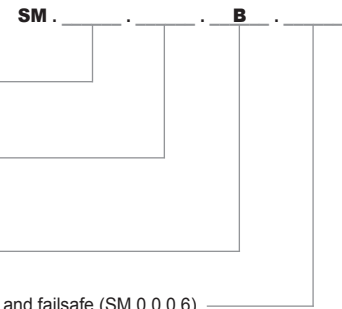

## ACTUATOR SPECIFICATIONS<sup>5</sup>

### FlowCon SM.0.0.0.3, SM.0.0.0.4, SM.0.0.0.5 (with BACnet) and SM.0.0.0.6 (with BACnet) actuators

Supply voltage:	24V AC/DC
Power consumption:	12VA
Frequency:	50/60 HZ
Control input:	0-10V DC, 2-10V DC, 0-20mA, 4-20mA, 2-position or 3-point floating
Feedback position output:	Automatic match of control input, 0-10V DC, 2-10V DC or 4-20mA
Turn time:	190 seconds (from closed to fully open valve)
Electrical connection:	5 wires 22 AWG halogen free cable, 1 meter For BACnet versions another 3 wires 22 AWG halogen free cable, 1 meter
Direction of rotation:	Bi-directional
Humidity rating:	5 to 95% RH non condensing
Housing material:	UL94 V0-rated plastic
Housing insulation:	IP54 including up-side-down mounting
Programming:	External programming of all settings, interface of buttons and display
Calibration:	Automatic calibration at startup
Valve - actuator coupling:	Easy snap coupling
BACnet device profile:	BACnet Application Specific Controller (B-ASC) type server
BACnet protocol:	BACnet Master Slave/Token passing (MS/TP)
BACnet baud rates supported:	9600, 19200, 38400 and 76800
BACnet services (BIBBS) supported:	DS-RP-B, DS-WP-B, DM-DDB-B, DM-DOB-B and DM-DCC-B.

Note 5: FlowCon warranty is voided using other actuators than supplied or recommended by FlowCon International.

## FLOW RATE TABLE

Model no.	Valve size		Control range		Minimum setting			Maximum setting		
	mm	inch	kPaD	psid	l/sec	l/hr	GPM	l/sec	l/hr	GPM
SM.3.0	50	2"	30-600	4.5-87	1.48	5310	23.4	4.16	15000	65.9
	65	2 1/2"								
	80	3"								
SM.3.1	50	2"	30-600	4.5-87	2.57	9240	40.7	7.15	25700	113
	65	2 1/2"								
	80	3"								
SM.3.2	50	2"	35-600	5.1-87	3.55	12800	56.3	9.89	35600	157
	65	2 1/2"								
	80	3"								
SM.4.1	80	3"	30-600	4.5-87	3.49	12600	55.4	9.38	33800	149
	100	4"								
SM.4.2	80	3"	35-600	5.1-87	4.73	17000	75.0	14.2	51000	225
	100	4"								
SM.4.3	80	3"	50-600	7.3-87	3.68	13300	58.3	20.2	72700	320
	100	4"								
SM.5.1	125	5"	30-600	4.5-87	6.48	23300	103	23.3	83800	369
	150	6"								
SM.5.2	125	5"	35-600	5.1-87	7.10	25600	113	29.5	106000	468
	150	6"								

Accuracy: Greatest of either  $\pm 5\%$  of controlled flow rate or  $\pm 2\%$  of maximum flow rate.

## CONTROL CURVE AT MAXIMUM PRE-SETTING<sup>6</sup>

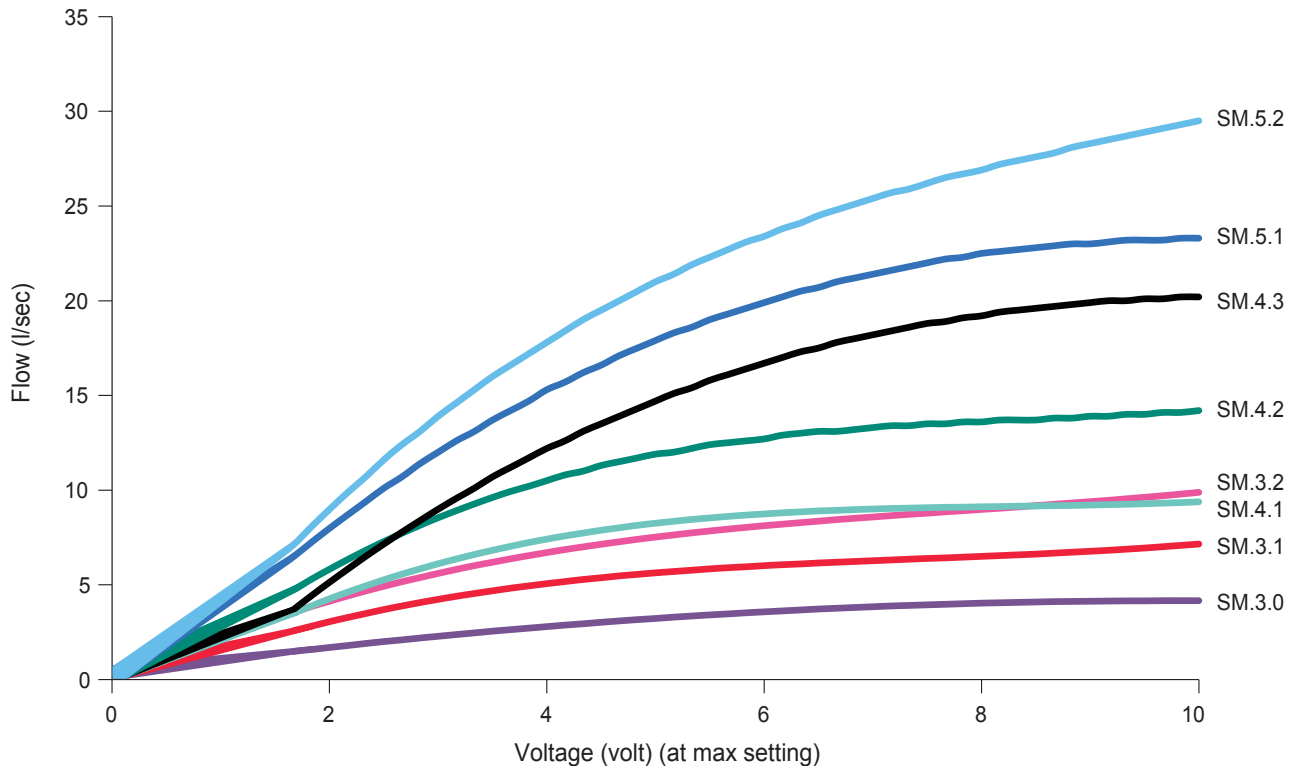

Note 6: Above curves show the control curve of the valves in maximum allowed pre-setting condition and may vary if lower pre-settings are selected. The valves will always have 1000 positions between the pre-set flow value and 0V if control range is selected to 0-10V.

## FLOW RATE SETTING<sup>7</sup> - VALVE SIZE DN50-DN150

Maximum Flow Rate								
Valve size: DN50-DN80 · 2"-3"								
30-600 kPaD 4.5-87 psid			30-600 kPaD 4.5-87 psid			35-600 kPaD 5.1-87 psid		
SM.3.0			SM.3.1			SM.3.2		
l/sec	l/hr	GPM	l/sec	l/hr	GPM	l/sec	l/hr	GPM
1.48	5310	23.4	2.57	9240	40.7	3.55	12800	56.3
1.58	5700	25.1	2.81	10100	44.6	3.85	13900	61.0
1.69	6080	26.8	3.05	11000	48.3	4.13	14900	65.5
1.79	6460	28.4	3.27	11800	51.9	4.41	15900	69.9
1.90	6830	30.1	3.49	12500	55.2	4.67	16800	74.0
2.00	7190	31.6	3.69	13300	58.4	4.92	17700	78.0
2.09	7540	33.2	3.88	14000	61.5	5.16	18600	81.7
2.19	7880	34.7	4.06	14600	64.3	5.38	19400	85.3
2.28	8220	36.2	4.23	15200	67.0	5.60	20200	88.8
2.37	8540	37.6	4.39	15800	69.6	5.81	20900	92.1
2.46	8860	39.0	4.54	16300	72.0	6.01	21600	95.2
2.55	9170	40.4	4.68	16900	74.2	6.19	22300	98.2
2.63	9470	41.7	4.82	17300	76.4	6.37	22900	101
2.71	9770	43.0	4.94	17800	78.4	6.54	23600	104
2.79	10100	44.3	5.06	18200	80.2	6.71	24100	106
2.87	10300	45.5	5.17	18600	82.0	6.86	24700	109
2.95	10600	46.7	5.28	19000	83.7	7.00	25200	111
3.02	10900	47.8	5.38	19400	85.2	7.14	25700	113
3.09	11100	49.0	5.47	19700	86.6	7.28	26200	115
3.16	11400	50.0	5.55	20000	88.0	7.40	26600	117
3.22	11600	51.1	5.63	20300	89.2	7.52	27100	119
3.29	11800	52.1	5.70	20500	90.4	7.63	27500	121
3.35	12000	53.1	5.77	20800	91.5	7.74	27900	123
3.41	12300	54.0	5.84	21000	92.5	7.84	28200	124
3.46	12500	54.9	5.90	21200	93.5	7.94	28600	126
3.52	12700	55.8	5.96	21400	94.4	8.03	28900	127
3.57	12900	56.6	6.01	21600	95.2	8.12	29200	129
3.62	13000	57.4	6.06	21800	96.0	8.20	29500	130
3.67	13200	58.2	6.10	22000	96.8	8.28	29800	131
3.72	13400	58.9	6.15	22100	97.5	8.36	30100	133
3.76	13500	59.6	6.19	22300	98.2	8.44	30400	134
3.80	13700	60.2	6.23	22600	98.8	8.51	30600	135
3.84	13800	60.9	6.27	22800	99.4	8.58	30900	136
3.88	14000	61.4	6.31	22700	101	8.65	31100	137
3.91	14100	62.0	6.35	22900	101	8.72	31400	138
3.94	14200	62.5	6.39	23000	101	8.78	31600	139
3.97	14300	63.0	6.42	23100	102	8.85	31900	140
4.00	14400	63.4	6.46	23300	102	8.91	32100	141
4.03	14500	63.8	6.50	23400	103	8.98	32300	142
4.05	14600	64.2	6.54	23500	104	9.04	32600	143
4.07	14700	64.5	6.58	23700	104	9.11	32800	144
4.09	14700	64.8	6.62	23800	105	9.18	33000	145
4.11	14800	65.1	6.67	24000	106	9.25	33300	147
4.12	14800	65.3	6.72	24200	106	9.32	33500	148
4.13	14900	65.5	6.77	24400	107	9.39	33800	149
4.14	14900	65.7	6.82	24600	108	9.46	34100	150
4.15	14900	65.8	6.88	24800	109	9.54	34300	151
4.16	15000	65.9	6.94	25000	110	9.62	34600	153
4.16	15000	65.9	7.01	25200	111	9.71	34900	154
4.16	15000	65.9	7.08	25500	112	9.79	35300	155
4.16	15000	65.9	7.15	25700	113	9.89	35600	157

Maximum Flow Rate								
Valve size: DN80 and DN100 · 3"-4"								
30-600 kPaD 4.5-87 psid			35-600 kPaD 5.1-87 psid			50-600 kPaD 7.3-87 psid		
SM.4.1			SM.4.2			SM.4.3		
l/sec	l/hr	GPM	l/sec	l/hr	GPM	l/sec	l/hr	GPM
3.49	12600	55.4	4.73	17000	75.0	3.68	13300	58.3
3.88	14000	61.6	5.29	19000	83.8	4.42	15900	70.0
4.26	15300	67.5	5.82	21000	92.3	5.13	18500	81.3
4.61	16600	73.0	6.33	22800	100	5.82	21000	92.3
4.94	17800	78.4	6.82	24500	108	6.50	23400	103
5.26	18900	83.4	7.28	26200	115	7.15	25700	113
5.56	20000	88.1	7.72	27800	122	7.78	28000	123
5.84	21000	92.6	8.14	29300	129	8.40	30200	133
6.11	22000	96.9	8.54	30700	135	8.99	32400	142
6.36	22900	101	8.91	32100	141	9.57	34400	152
6.60	23800	105	9.27	33400	147	10.1	36400	160
6.82	24600	108	9.61	34600	152	10.7	38400	169
7.03	25300	111	9.93	35700	157	11.2	40200	177
7.23	26000	115	10.2	36800	162	11.7	42100	185
7.41	26700	117	10.5	37800	167	12.2	43800	193
7.58	27300	120	10.8	38800	171	12.6	45500	200
7.73	27800	123	11.0	39700	175	13.1	47100	207
7.88	28400	125	11.3	40500	178	13.5	48700	214
8.01	28800	127	11.5	41300	182	13.9	50200	221
8.14	29300	129	11.7	42000	185	14.3	51600	227
8.25	29700	131	11.9	42700	188	14.7	53000	233
8.35	30100	132	12.0	43400	191	15.1	54300	239
8.45	30400	134	12.2	43900	194	15.4	55600	245
8.53	30700	135	12.4	44500	196	15.8	56800	250
8.61	31000	137	12.5	45000	198	16.1	58000	255
8.68	31300	138	12.6	45500	200	16.4	59100	260
8.75	31500	139	12.7	45900	202	16.7	60200	265
8.80	31700	140	12.9	46300	204	17.0	61200	269
8.85	31900	140	13.0	46700	205	17.3	62100	274
8.90	32000	141	13.1	47000	207	17.5	63000	278
8.94	32200	142	13.1	47300	208	17.8	63900	281
8.97	32300	142	13.2	47600	209	18.0	64700	285
9.00	32400	143	13.3	47800	210	18.2	65500	288
9.03	32500	143	13.4	48100	212	18.4	66200	292
9.05	32600	143	13.4	48300	213	18.6	66900	295
9.07	32600	144	13.5	48500	214	18.8	67600	297
9.09	32700	144	13.5	48700	214	18.9	68200	300
9.10	32800	144	13.6	48800	215	19.1	68700	303
9.12	32800	145	13.6	49000	216	19.2	69200	305
9.13	32900	145	13.7	49200	217	19.4	69700	307
9.15	32900	145	13.7	49300	217	19.5	70200	309
9.16	33000	145	13.7	49500	218	19.6	70600	311
9.18	33000	145	13.8	49600	218	19.7	70900	312
9.19	33100	146	13.8	49800	219	19.8	71300	314
9.21	33200	146	13.9	49900	220	19.9	71600	315
9.23	33200	146	13.9	50100	220	20.0	71900	316
9.25	33300	147	14.0	50200	221	20.0	72100	317
9.28	33400	147	14.0	50400	222	20.1	72300	318
9.31	33500	148	14.1	50600	223	20.1	72500	319
9.34	33600	148	14.1	50800	224	20.2	72600	320
9.38	33800	149	14.2	51000	225	20.2	72700	320

Maximum Flow Rate					
Valve size: DN125 and DN150 · 5"-6"					
30-600 kPaD 4.5-87 psid			35-600 kPaD 5.1-87 psid		
SM.5.1			SM.5.2		
l/sec	l/hr	GPM	l/sec	l/hr	GPM
6.48	23300	103	7.10	25600	113
7.24	26100	115	8.06	29000	128
7.98	28700	126	8.98	32300	142
8.70	31300	138	9.87	35500	157
9.39	33800	149	10.7	38600	170
10.1	36200	160	11.6	41600	183
10.7	38600	170	12.4	44500	196
11.4	40900	180	13.1	47300	208
12.0	43100	190	13.9	50000	220
12.6	45200	199	14.6	52600	232
13.1	47300	208	15.3	55100	243
13.7	49300	217	16.0	57500	253
14.2	51200	226	16.6	59800	264
14.8	53100	234	17.2	62100	273
15.3	54900	242	17.8	64200	283
15.7	56600	249	18.4	66300	292
16.2	58300	257	19.0	68300	301
16.6	59900	264	19.5	70200	309
17.1	61500	271	20.0	72100	317
17.5	63000	277	20.5	73800	325
17.9	64400	284	21.0	75500	333
18.3	65800	290	21.4	77200	340
18.6	67100	295	21.9	78700	347
19.0	68300	301	22.3	80200	353
19.3	69500	306	22.7	81700	360
19.6	70700	311	23.1	83100	366
19.9	71700	316	23.4	84400	372
20.2	72800	320	23.8	85700	377
20.5	73800	325	24.1	86900	383
20.7	74700	329	24.5	88100	388
21.0	75600	333	24.8	89200	393
21.2	76400	336	25.1	90300	398
21.4	77200	340	25.4	91400	402
21.6	77900	343	25.7	92400	407
21.8	78600	346	25.9	93400	411
22.0	79200	349	26.2	94300	415
22.2	79800	351	26.5	95200	419
22.3	80300	354	26.7	96100	423
22.5	80800	356	26.9	97000	427
22.6	81300	358	27.2	97800	431
22.7	81700	360	27.4	98600	434
22.8	82100	361	27.6	99400	438
22.9	82400	363	27.8	100000	441
23.0	82700				

## FLANGE MATCH SM HOUSING

Model no.	Flange size (inch)	ASME B16.5 weld neck flanges		ASME B16.5 slip on flanges		Flange size (mm)	EN1092-1 <sup>8</sup>				EN1092-1 <sup>9</sup>			
		Class 150	Class 300	Class 150	Class 300		PN10	PN16	PN25	PN40	PN10	PN16	PN25	PN40
SM.3.x	2	-	✓	-	✓	50	✓	✓	✓	✓	✓	✓	✓	✓
	2 1/2	✓	✓	✓	✓	65	✓	✓	✓	✓	✓	✓	✓	✓
	3	✓	✓	-	-	80	✓	✓	✓	✓	-	-	-	-
SM.4.x	3	✓	✓	✓	✓	80	✓	✓	✓	✓	✓	✓	✓	✓
	4	✓	✓	-	-	100	✓	✓	✓	✓	-	-	-	-
SM.5.x	5	✓	✓	✓	✓	125	✓	✓	✓	✓	✓	✓	✓	✓
	6	✓	-	-	-	150	✓	✓	✓	✓	-	-	-	-

Note 8: Type 02 and 35/36/37 (loose plate flange with welding neck / pressed collar with long neck / pressed collar) or Type 04 and 34 (loose plate flange with weld-neck collar) or Type 11 with flange facing A/B (weld-neck flange with flat face or raised face).

Note 9: Type 12 with flange facing A/B (hubbed slip-on flange with flat face or raised face).

## GENERAL DESCRIPTION

The SM Series are self balancing dynamic flow control valves that are pressure independent, two-way, modulating to accept digital or analog input signals. The valves accept 2-10V DC, 4-20mA, digital 2-position or digital 3-point floating input signals. Each valve has an adjustable maximum flow rate setting to enable flow limitation and balancing to the coils or zones that the valves are controlling.

All SM actuators are microprocessor based with a self-calibrating feature.

The SM valve is of the wafer style for fitting between flanges. They are available in three different valve bodies for flange connections.

## GENERAL SPECIFICATIONS

### 1. PRESSURE INDEPENDENT DYNAMIC CONTROL VALVE FLOWCON SM

- 1.1. Contractor shall install dynamic control valves where indicated in drawings.
- 1.2. Valve shall be an electronic, dynamic, modulating, 2-way pressure independent control device.
- 1.3. Pressure independent dynamic control valve shall accurately control flow, independent of system pressure fluctuation.
- 1.4. Maximum flow setting shall be adjustable to 51 different settings within the range of the valve size.
- 1.5. Valve and actuator coupling shall have snap couplings for fast mounting and demounting.

### 2. VALVE ACTUATOR

- 2.1. Valve and actuator coupling shall have snap couplings for fast mounting and demounting.
- 2.2. Actuator housing shall be rated to IP54 including up-side-down mounting.
- 2.3. Actuator shall be driven by a 24V AC/DC motor and shall accept 0-10V DC, 2-10V DC, 0-20mA, 4-20mA, 2-position or 3-point floating electric input signal.
- 2.4. Actuator shall be capable of providing same as input, 4-20mA, 0-10V DC or 2-10V DC feedback signal to the control system.
- 2.5. Automatic calibration of valve position shall be standard.
- 2.6. Actuator shall include display and buttons for external programming of all settings.
- 2.7. External display of current valve flow, maximum valve flow, input signal, feedback signal and operational direction shall be standard.
- 2.8. Optional fail safe system to power valve to either open (max. setting) or closed position from any position in case of power failure shall be available.
- 2.9. Optional BACnet connection for remote setting and control of actuator shall be available.

*continues...*

## GENERAL SPECIFICATIONS (continued)

### 3. VALVE HOUSING

- 3.1. Valve housing shall consist of ductile iron ASTM A395 Grade 60-40-18 rated at no less than 4000 kPa static pressure and +120°C.
- 3.2. Valve housing shall be permanently marked to show direction of flow.
- 3.3. Valve housing shall be for installation between flanges.
- 3.4. Dual pressure/temperature test plugs for verifying accuracy of flow performance shall be provided for all valve sizes.
- 3.5. Identification label according to PED-requirements shall be available for all valves.

### 4. FLOW REGULATOR / AUTOMATIC BALANCING UNIT

- 4.1. Flow regulation unit shall be manufactured of stainless steel and hydrogenated acrylonitrile-butadiene-rubber and shall be capable of controlling flow within  $\pm 5\%$  rated flow rate or  $\pm 2\%$  of maximum flow rate.
- 4.2. Flow regulation unit shall be accessible for change-out or maintenance.

## APPLICATION AND SCHEMATIC EXAMPLE

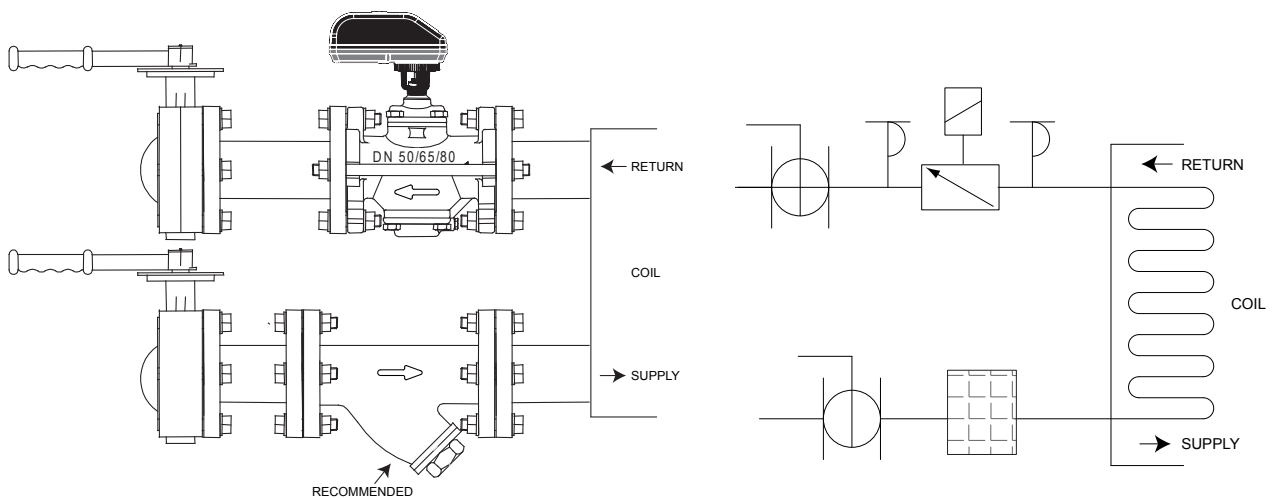

## UPDATES

For latest updates please see [www.flowcon.com](http://www.flowcon.com)

FlowCon International can accept no responsibility for possible errors in any printed material.  
All rights reserved.

# FlowCon EVS / EVC / ABM

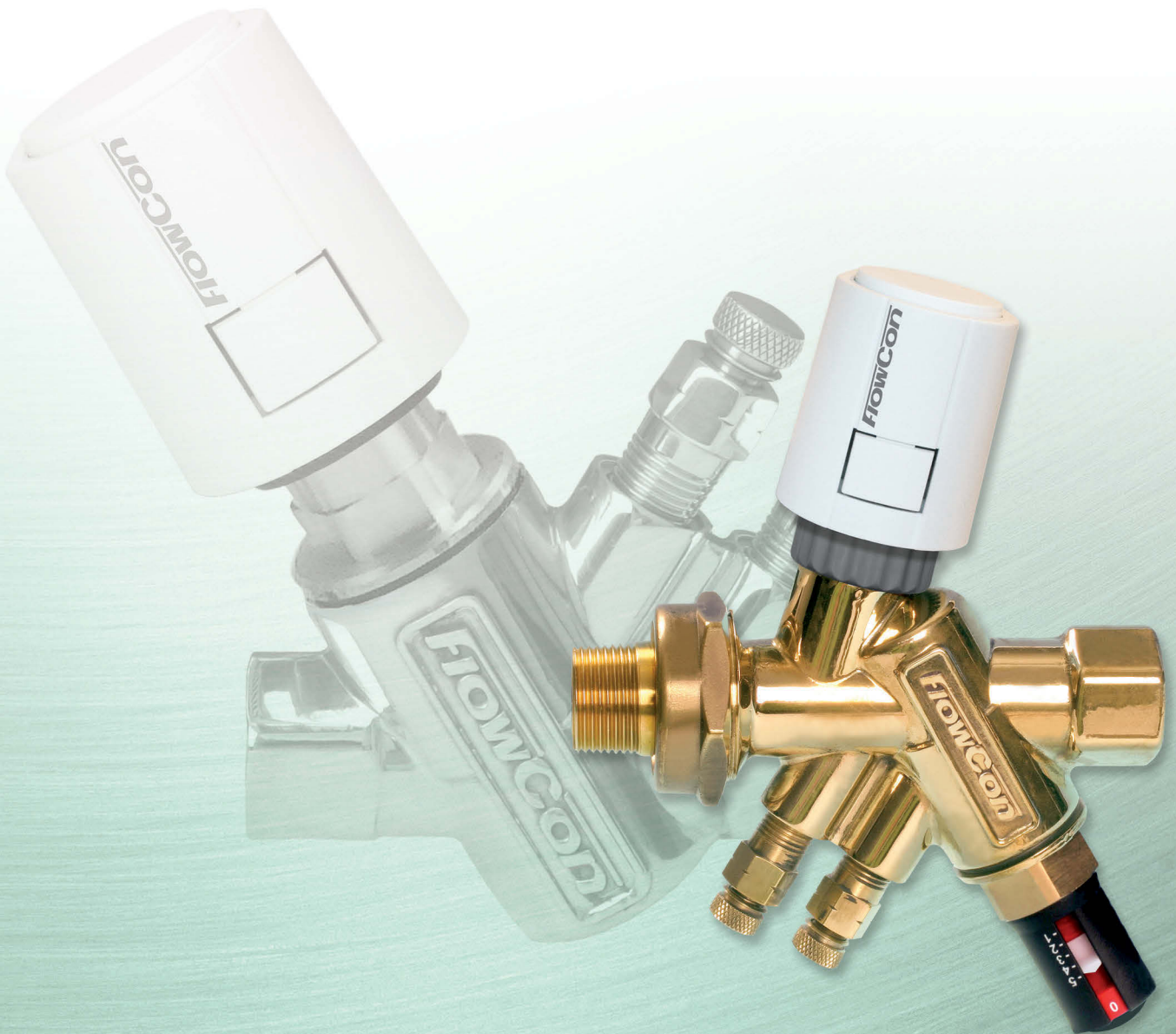

*Balanced Temperature Control Valves*

# FlowCon EVS, EVC and ABM

*Temperature Control and Automatic Balancing combined in a Single Unit for Total Flow Control*

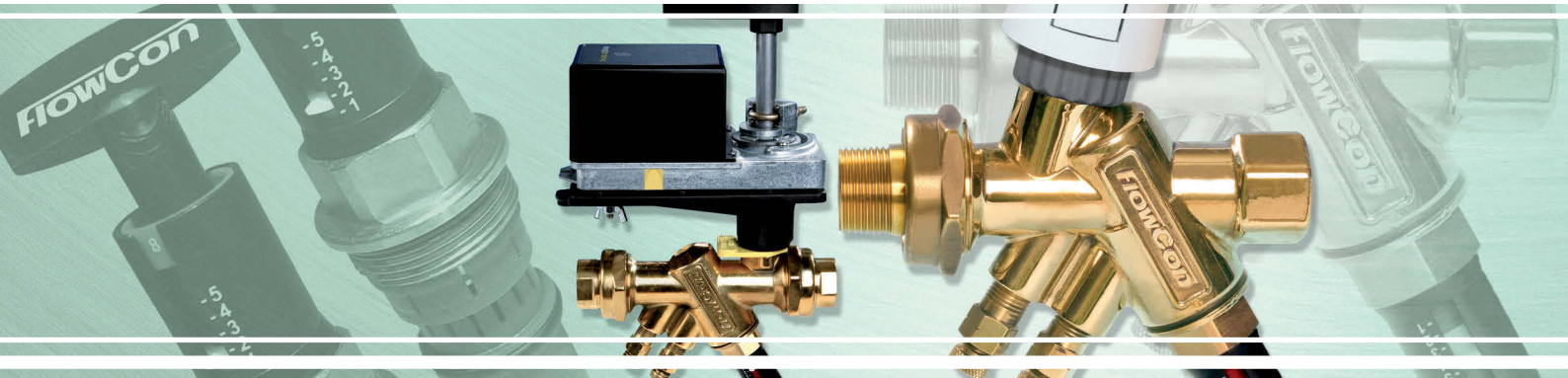

The FlowCon EVS and EVC valves are particularly designed to give the optimal indoor comfort. The valves will provide ON/OFF or analog temperature control and self balancing flow control for use with fan coil units in air-conditioning and cooling ceilings or as zone valve in heating systems.

For larger applications the "sister model" FlowCon ABM can be used. The ABM valve is suitable for applications in connection with building automation systems where central control of the comfort in the building is required. This model combines an electrically actuated ball valve in series with an automatic flow limiting insert.

The flow regulator is different within the three types, i.e. FlowCon EVS is regulated by a stainless steel insert and the FlowCon EVC and ABM by an adjustable composite insert.

The EVS-insert is designed for use in connection with the valve bodies FlowCon A, AB or ABV1. The EVC valve has its own unique valve house. The ABM valve is designed for use with the FlowCon ABV-bodies with modification to the ball valve. The control signal for either actuator can be provided by for instance a thermostat.

## **Features and Benefits**

- **Automatic balancing**, the correct flow rate for each circuit is achieved automatically.
- **Dynamic balancing**, the correct flow rate is maintained as each valve compensates for pressure fluctuations in the system.
- **Actuator** selection, ON/OFF or analog, normally closed.
- **Easily accessible insert** for flow rate adjustment or maintenance.
- **Pressure/temperature measurement plugs** for verifying operating pressure differential range or checking  $\Delta T$  across the coil (not available on FlowCon A-bodies).
- **Union end connection** for ease of installation and wide selection of end fittings (FlowCon ABV, EVC and ABM) or **fixed female threaded ends** (FlowCon A and AB).



**Principle of Insert Operation  
- FlowCon EVC and ABM**

The FlowCon EVC and ABM valves utilize an adjustable composite insert. The internal adjustable insert is adjusted by means of a 6mm Hex key to one of 8 different flow rates. The external adjustable insert, called the FlowCon E-JUST, is operated by means of a special FlowCon key, and flow rate is chosen from 41 different possibilities.

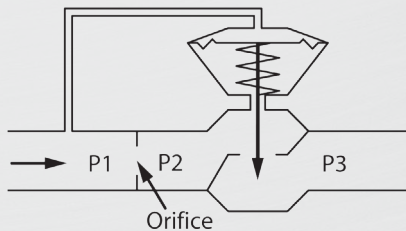

For the FlowCon EVC and ABM, the principle of operation is shown above and the principle of construction is shown below. P1 and P3 are system pressures,  $P1+P3$  is the total pressure drop across the valve. P2 is set by the diaphragm acting in reaction to P1 in the upper diaphragm chamber. Interacting with the spring,  $P1+P2$  remains constant, keeping a constant  $\Delta P$  across the orifice areas. The result is a constant flow rate through the valve, independent of pressure fluctuations.

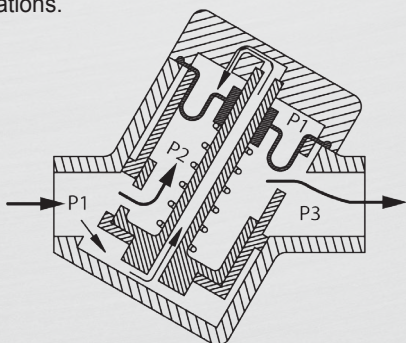

Below its pressure differential range, the valve acts as a fixed orifice. This allows the temperature control part of the valve to operate with valve authority up to the set flow rate maximum.

In case the differential pressure is higher than the defined max.  $\Delta P$  for the insert, the diaphragm may be damaged.

**Principle of Insert Operation  
- FlowCon EVS**

The FlowCon EVS valve utilizes a factory pre-set stainless steel insert. Below its pressure differential range it acts as a fixed orifice.

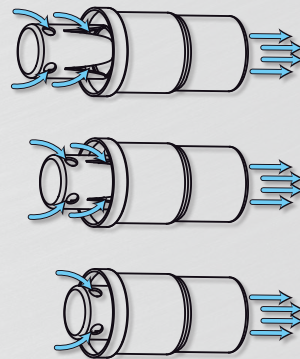

Within operating pressure differential range, the effective open orifice area of the insert is automatically adjusted to the point where the specified flow rate will be delivered (as the pressure differential increases, the open area closes and as it decreases, the area opens).

When the pressure differential range is exceeded, the valve again becomes a fixed orifice device. This ensures that no part of the system is starved or shut down.

**Equal Percentage Control Characteristic**

The patented parabolic Optimizer® in the FlowCon ABM is unique from any other in the industry because it is actually press-fitted into the ball, resulting in less wear and higher close-off pressure. Optimizer® means equal percentage flow characteristic and linear heat transfer, i.e. the heat output at the coil is linear when compared to the open area of the valve.

The physical design of the Optimizer® means that once it is press-fitted into the ball, it cannot be forced out because the back side of the Optimizer® is too large to be forced through the ball's port.

As pressure increases behind the Optimizer® insert, it compresses even further into the ball's port, making a tight fit even tighter for guaranteed protection against leak-by.

The Optimizer® is able to modulate in systems where the differential pressure is over 1100 kPaD without influencing life or performance of the Optimizer®, which is quite unique compared with other similar solutions.



Illustration of Optimizer® movement.

**Technical Data**

For further information and part number selection pls. see FlowCon tech note and the catalogue: FlowCon Inserts. For latest updates please see [www.flowcon.com](http://www.flowcon.com)

	A/AB/ABV DN15/20/25 with EVS insert	EVC DN15/20/25	ABM DN15/20/25	ABM DN25/32/40
Static Pressure (kPa) (psi)	2500	1600	2500	2500
	360	230	360	360
Temperature Rating (°C) Media/Ambient (°F)	-20 to +120 / 0 to +60	-20 to +120 / 0 to +60	-20 to +120 / 0 to +50	-20 to +120 / 0 to +50
	-4 to +248 / 32+ to +140	-4 to +248 / 32+ to +140	-4 to +248 / +32 to +122	-4 to +248 / +32 to +122
Pressure Drop Data	NOTE: For pump head calculations, add the minimum pressure differential for the index circuit to the other components pressure losses (i.e. valves, coil, etc.)			
Valve Body	Kv-value	3.1	2.00	Depend on Optimizer®
	Cv-value	3.6	2.33	Depend on Optimizer®

Stainless Steel Insert	F3601XX	F3602XX	F3604XX		
Insert Size (mm)	20	20	20	Available with an adapter	Available with an adapter
(inch)	3/4	3/4	3/4		
Pressure Differential (kPaD) (psid)	10-95	22-210	40-390		
	1-14	2-32	4-57		
Flow Rate (l/sec) (GPM)	0.0210-0.315	0.0347-0.505	0.0473-0.631		
	0.333-5.00	0.550-8.00	0.750-10.0		

Standard Composite Cart.		ABV1.Y.X <sup>1</sup> grey/red/blue/black/green	ABV1.G.X <sup>1</sup> grey/red/blue/black/green	ABV2.X.X red/white	ABV2.C.X red/white	ABV2.D.X red/white
Insert Size (mm) (inch)	N/A	20	20	40	40	40
		3/4	3/4	1 1/2	1 1/2	1 1/2
Pressure Differential (kPaD) (psid)	N/A	15-130	30-400	15-130	22-300	30-410
		2.2-18.9	4.4-58	2.2-18.9	3.2-43.5	4.4-59.5
Flow Rate (l/sec) (GPM)	N/A	0.0081-0.273	0.0117-0.408	0.17-0.85	0.23-1.21	0.27-1.43
		0.13-4.33	0.185-6.46	2.69-13.5	3.65-19.2	4.28-22.7

E-JUST Insert		E-JUST1.Y.X <sup>1</sup> black/green	E-JUST1.Y.R <sup>1</sup> red	E-JUST1.G.R <sup>1</sup> red	E-JUST1.G.X <sup>1</sup> black/green	E-JUST2.Y.G green
Insert Size (mm) (inch)	N/A	20	20	20	20	40
		3/4	3/4	3/4	3/4	1 1/2
Pressure Differential (kPaD) (psid)	N/A	17-210	17-200	30-400	35-400	17-400
		2.5-30	2.5-29	4.4-58	5.1-58	2.5-58
Flow Rate (l/sec) (GPM)	N/A	0.0278-0.169	0.0767-0.229	0.113-0.352	0.0383-0.249	0.149-1.62
		0.44-2.68	1.22-3.60	1.79-5.57	0.61-3.94	2.36-25.7

Note 1: Standard composite insert type Y and G and E-JUST insert type Y and G are to be used in either EVC DN15/20/25 or in ABM DN15/20/25.



A Griswold Controls LLC./FlowCon International Company

[www.flowcon.com](http://www.flowcon.com)

D E N M A R K . D U B A I . U S A . S I N G A P O R E

## FlowCon EVS 15-25mm

*Plug-in Insert for Temperature Control  
of Automatic Balancing Valve*

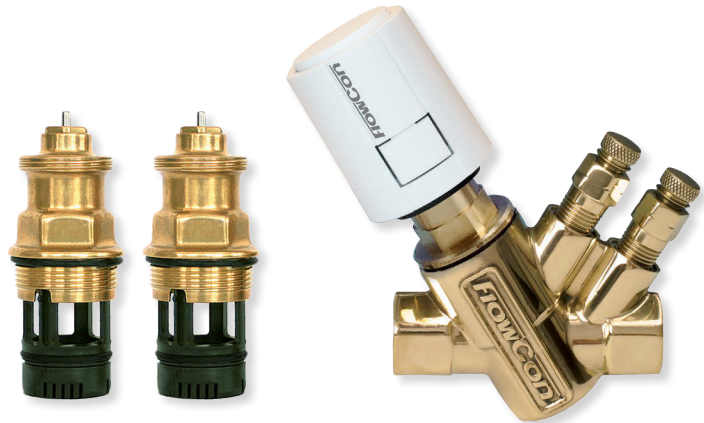

### SPECIFICATIONS

#### **Insert:**

Pressure rating:	2500 kPa / 360 psi
Temperature rating, media <sup>1</sup> :	-20°C to +120°C / -4°F to +248°F
Temperature rating, ambient:	0°C to +60°C / +32°F to +140°F
Material:	
- Insert:	Stainless steel AISI type 304
- Body:	Brass ASTM B584 and polyoxymethylene
- Spring:	Stainless steel type 17-7
- Spindel:	Brass
- Seat plug and o-rings:	EPDM
Maximum close off pressure:	400 kPa / 58 psi
Shut off leakage:	IEC 60534-4 - Class V
Flow rate range:	0.0210-0.631 l/sec

#### **Valve:**

Material:	
- Body:	Forged brass ASTM CuZn40Pb2
- Ball valve:	ABV: Chemically nickel plated brass ball
End Connections:	A: Female ISO or NPT
	AB: Female ISO or NPT
	ABV: Union end connections in brass alloy ISO or NPT

Note 1: Stated temperature rating is defined due to no external spindle condensation.

## SPECIFICATIONS (...continued)

### FlowCon Actuators:

FlowCon Actuator <sup>2</sup>	EV.0.2	EV.0.3	EV.0.4	EV.0.5	EV.1.3	EV.1.4
Supply voltage	24V AC -10%/+20% 50/60Hz	230V AC ±10% 50/60Hz	24V AC/DC -10%/+20% 50/60Hz	120V AC ±10% 50/60Hz	230V AC ±10% 50/60Hz	24V AC/DC -10%/+20% 50/60Hz
Power consumption	1.0 watt	1.0 watt	1.0 watt	1.0 watt	1.0 watt	1.0 watt
Control signal	0-10V DC normally closed <sup>3</sup>	ON/OFF normally closed <sup>3</sup>	ON/OFF normally closed <sup>3</sup>	ON/OFF normally closed <sup>3</sup>	ON/OFF normally closed <sup>3</sup>	ON/OFF normally closed <sup>3</sup>
Operation time	Approx. 2½ min	Approx. 4 min	Approx. 4 min	Approx. 4 min	Approx. 4 min	Approx. 4 min
Ambient temperature	0°C to +60°C	0°C to +60°C	0°C to +60°C	0°C to +60°C	0°C to +60°C	0°C to +60°C
Protection	IP54, class III	IP54, class II	IP54, class III	IP54, class II	IP54, class II	IP54
Cable	Plug-in, 1 meter	Fixed, 1 meter	Fixed, 1 meter	Fixed, 1 meter	Fixed, 1 meter	Fixed, 1 meter
Weight	0.119 kg <sup>4</sup>	0.108 kg <sup>4</sup>	0.108 kg <sup>4</sup>	0.108 kg <sup>4</sup>	0.158 kg <sup>4</sup>	0.158 kg <sup>4</sup>
Including end switch	No	No	No	No	Yes	Yes
Switching point	N/A	N/A	N/A	N/A	Approx. 2mm	Approx. 2mm
Switching capacity	N/A	N/A	N/A	N/A	230V AC 5A ohm resistive load 1A inductive load	24V AC 3A ohm resistive load 1A inductive load

Note 2: FlowCon warranty is voided using other actuators than supplied or recommended by FlowCon International.

Note 3: To ensure that the valve is in an open position during commission of the system, the actuator will be delivered in a normal open position and remain in this position until it is electrically operated first time.

Note 4: The weight includes actuator, adaptor ring and 1 meter cable.

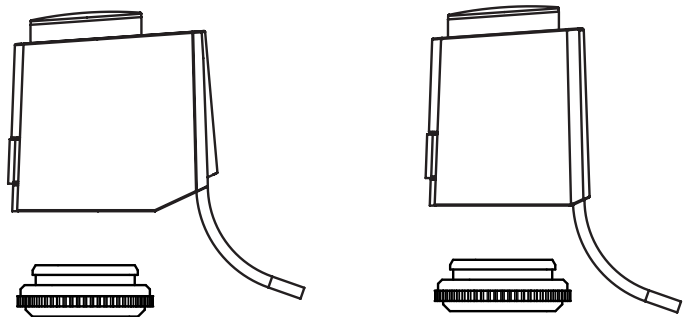

*FlowCon EV.0.2,  
EV.1.3 and EV.1.4  
Valve adaptor, black*

*FlowCon EV.0.3,  
EV.0.4 and EV.0.5  
Valve adaptor, black*

## DIMENSIONS AND WEIGHTS (NOMINAL) (measured in mm unless noted)

Valve model	Actuator model	Valve size	Insert size	L	H1	H2	End connections C <sup>5</sup>			Weight <sup>6</sup> (kgs.)	Kv <sup>7</sup> (m <sup>3</sup> /hr)
							ISO female	ISO male	Sweat		
A	EV.0.2 EV.1.3 EV.1.4	15	20	80	30.6	120	-	-	-	0.55	3.1
		20		91						0.50	
		25		91						0.65	
	EV.0.3 EV.0.4 EV.0.5	15	20	80	30.6	117	-	-	-	0.55	3.1
		20		91						0.50	
		25		91						0.60	
AB	EV.0.2 EV.1.3 EV.1.4	15	20	82	30.6	120	-	-	-	0.60	3.1
		20		94						0.65	
		25		102						0.80	
	EV.0.3 EV.0.4 EV.0.5	15	20	82	30.6	117	-	-	-	0.60	3.1
		20		94						0.65	
		25		102						0.80	
ABV1	EV.0.2 EV.1.3 EV.1.4	15	20	122	33.0	120	22	24	20	0.90	3.1
		20					22	25	20		
		25					-	39	22		
	EV.0.3 EV.0.4 EV.0.5	15	20	122	33.0	117	22	24	20	0.90	3.1
		20					22	25	20		
		25					-	39	22		

Note 5: Add end connection length to body length.

Note 6: The weight is without end connections and actuator, the weight of the actuator is available at page 2.

Note 7: For valve body.

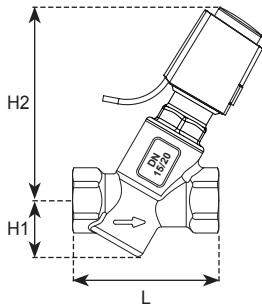

FlowCon EV.0.3, EV.0.4 and EV.0.5  
on FlowCon A

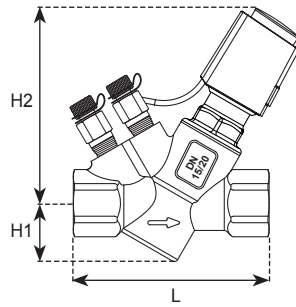

FlowCon EV.0.3, EV.0.4 and EV.0.5  
on FlowCon AB 15/20mm

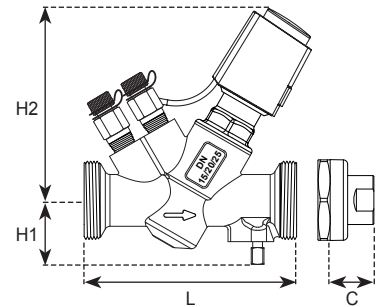

FlowCon EV.0.3, EV.0.4 and EV.0.5  
on FlowCon ABV1

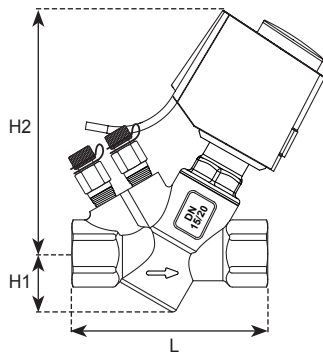

FlowCon EV.0.2, EV.1.3 and EV.1.4  
on FlowCon AB 15/20mm

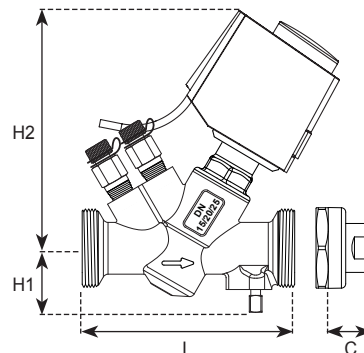

FlowCon EV.0.2, EV.1.3 and EV.1.4  
on FlowCon ABV1

## MODEL NUMBER SELECTION

**EVS**

Insert type of actuator:

**2**=EV.0.2 **3**=EV.0.3 **4**=EV.0.4 **5**=EV.1.3 **6**=EV.1.4 **7**=EV.0.5

Insert type of body:

**01**=AB15 **02**=AB20 **03**=ABV1(15/20/25) **04**=A15  
**05**=A20 **06**=A25 **09**=AB25

Insert p/t plug requirements:

Leave it **blank** if no p/t plugs are required **B**=pressure/temperature plugs **P**=taps plugged

Insert inlet x outlet union end connections - leave it **blank** if A- or AB-body or no end connections required:

Body size	Female threaded	Male treaded	Sweat
Union end 15-25mm, 1/2"-1"	<b>E</b> =15mm=1/2" <b>F</b> =20mm=3/4"	<b>H</b> =15mm=1/2" <b>I</b> =20mm=3/4" <b>J</b> =25mm=1"	<b>K</b> =15mm <b>L</b> =18mm <b>M</b> =22mm

Insert connection standard:

**I**=ISO **N**=NPT

Insert kPaD control range:

**1**=10-95 kPaD **2**=22-210 kPaD **4**=40-390 kPaD - leave blank if no insert is required

Insert automatic flow limiting insert code:

(Determine from insert selection chart)

Example: EVS.2.01.P.I.F360206.2=EVS insert in AB 15mm ISO female threaded body with plugs, 24V modulating actuator and a F360206 insert (0.189 l/sec, 22-210 kPaD).

## FLOW RATE TABLE - STAINLESS STEEL INSERT - FOR VALVES DN15-DN25

20mm · 3/4" stainless steel insert									
Pressure range, ΔP:			10-95 kPaD 1-14 psid		22-210 kPaD 2-32 psid		40-390 kPaD 4-57 psid		
Nominal flow rate				Type 1		Type 2		Type 4	
	I/sec	I/hr	GPM	Marking	FlowCon	Marking	FlowCon	Marking	FlowCon
	0.0210	75.7	0.333	11-1	F360111				
0.0315	114	0.500	01-1	F360101					
0.0347	125	0.550			11-2	F360211			
0.0421	151	0.667	02-1	F360102					
0.0473	170	0.750			01-2	F360201	11-4	F360411	
0.0631	227	1.00	03-1	F360103	02-2	F360202	01-4	F360401	
0.0694	250	1.10							
0.0841	303	1.33	04-1	F360104			02-4	F360402	
0.0946	341	1.50			03-2	F360203			
0.105	379	1.67	05-1	F360105					
0.126	454	2.00	06-1	F360106	04-2	F360204	03-4	F360403	
0.147	530	2.33	07-1	F360107					
0.158	568	2.50			05-2	F360205			
0.168	606	2.67	08-1	F360108			04-4	F360404	
0.189	681	3.00			06-2	F360206			
0.210	757	3.33	10-1	F360110			05-4	F360405	
0.221	795	3.50			07-2	F360207			
0.252	908	4.00	12-1	F360112	08-2	F360208	06-4	F360406	
0.294	1060	4.67	14-1	F360114			07-4	F360407	
0.315	1140	5.00	16-1	F360116	10-2	F360210			
0.336	1210	5.33					08-4	F360408	
0.379	1360	6.00			12-2	F360212			
0.421	1511	6.67					10-4	F360410	
0.442	1590	7.00			14-2	F360214			
0.505	1820	8.00			16-2	F360216	12-4	F360412	
0.589	2120	9.33					14-4	F360414	
0.631	2270	10.0					16-4	F360416	

Accuracy: ±5% of controlled flow rate.

## ACCESSORIES

- P/t plugs: 2 x ACC00101
- Plugs and gaskets: 2 x ACC1B03000
- Spare part, black composite part: EVS.0.0.1.

## GENERAL DESCRIPTION

The standard actuators available for the FlowCon EVS valve are thermal actuators that operate ON/OFF on 24V AC/DC, 120V AC and 230V AC/DC or modulating on 24V AC respectively. ON/OFF actuators are available with end switches which can be used for controlling the fan in priority to the open position of the valve.

The EVS-insert with stainless steel insert will in connection with the FlowCon A, AB and ABV1 valve bodies provide temperature control and dynamic balancing for use in cooling ceilings, fan coil units in air-condition or as zone valve in heating systems.

## GENERAL SPECIFICATIONS

### 1. AUTOMATIC BALANCING AND TEMPERATURE CONTROL VALVES - FLOWCON EVS + FLOWCON A, AB or ABV1.

- 1.1. Contractor shall install balancing / temperature valves where indicated in drawings.
- 1.2. The flow limiting device shall be available as a plug-in device for an inline valve housing.

### 2. VALVE ACTUATOR

- 2.1. Actuator shall provide a visual indication of the valve position.
- 2.2. The valve shall be closing when the actuator is not powered.
- 2.3. The valve shall withstand a shut off pressure of at least 400 kPa without allowing internal leakage.
- 2.4. The seat plug shall be manufactured of EPDM rubber.
- 2.5. The packing box for sealing the stem shall be removable with the system in operation, without allowing external leakage.

### 3. VALVE INSERT

- 3.1. The insert shall consist of forged brass ASTM B584 and polyoxymethylene, rated at no less than 2500 kPa static pressure and +120°C.
- 3.2. The insert shall include a lock-ring for fast fitting and re-fitting of flow regulation unit.

### 4. VALVE HOUSING

#### 4.a. FlowCon A

- 4.a.1. Valve housing shall consist of forged brass ASTM CuZn40Pb2, rated at no less than 2500 kPa static pressure and +120°C.
- 4.a.2. Valve housing shall be permanently marked to show direction of flow.
- 4.a.3. Housing shall be configured for flow regulation unit accessibility.

OR....

#### 4.b. FlowCon AB

- 4.b.1. Valve housing shall consist of forged brass ASTM CuZn40Pb2, rated at no less than 2500 kPa static pressure and +120°C.
- 4.b.2. Valve housing shall be permanently marked to show direction of flow.
- 4.b.3. Optional pressure/temperature test plugs for verifying accuracy of flow performance shall be available for all valve sizes.
- 4.b.4. Housing shall be configured for flow regulation unit accessibility.

OR....

#### 4.c. FlowCon ABV

- 4.c.1. Valve housing shall consist of forged brass ASTM CuZn40Pb2, rated at no less than 2500 kPa static pressure and +120°C.
- 4.c.2. Valve housing shall be permanently marked to show direction of flow.
- 4.c.3. Valve housing shall be double union end constructed with a range of pipe connections available for the appropriate pipe size.
- 4.c.4. Valve ball shall consist of chemically nickel plated brass (ASTM CuZn40Pb2).
- 4.c.5. Optional pressure/temperature test plugs for verifying accuracy of flow performance shall be available for all valve sizes.
- 4.c.6. Housing shall be configured for flow regulation unit accessibility.

## GENERAL SPECIFICATIONS (continued)

### 5. FLOW REGULATOR / AUTOMATIC BALANCING UNIT

- 5.1. Flow regulation unit assembly shall be manufactured of AISI type 304 stainless steel and stainless steel 17-7 spring.
- 5.2. Flow regulation unit shall be readily accessible for change-out or maintenance.
- 5.3. Flow regulation unit shall be available in 3 different kPaD operational ranges, minimum range shall be capable of being activated by minimum 10 kPaD. Further, the flow regulation unit shall be capable of controlling flow within  $\pm 5\%$  of rated flow.
- 5.4. Identification tags shall be available for all valves; tags shall be indelibly marked with part number and flow rate.

## APPLICATION AND SCHEMATIC EXAMPLE

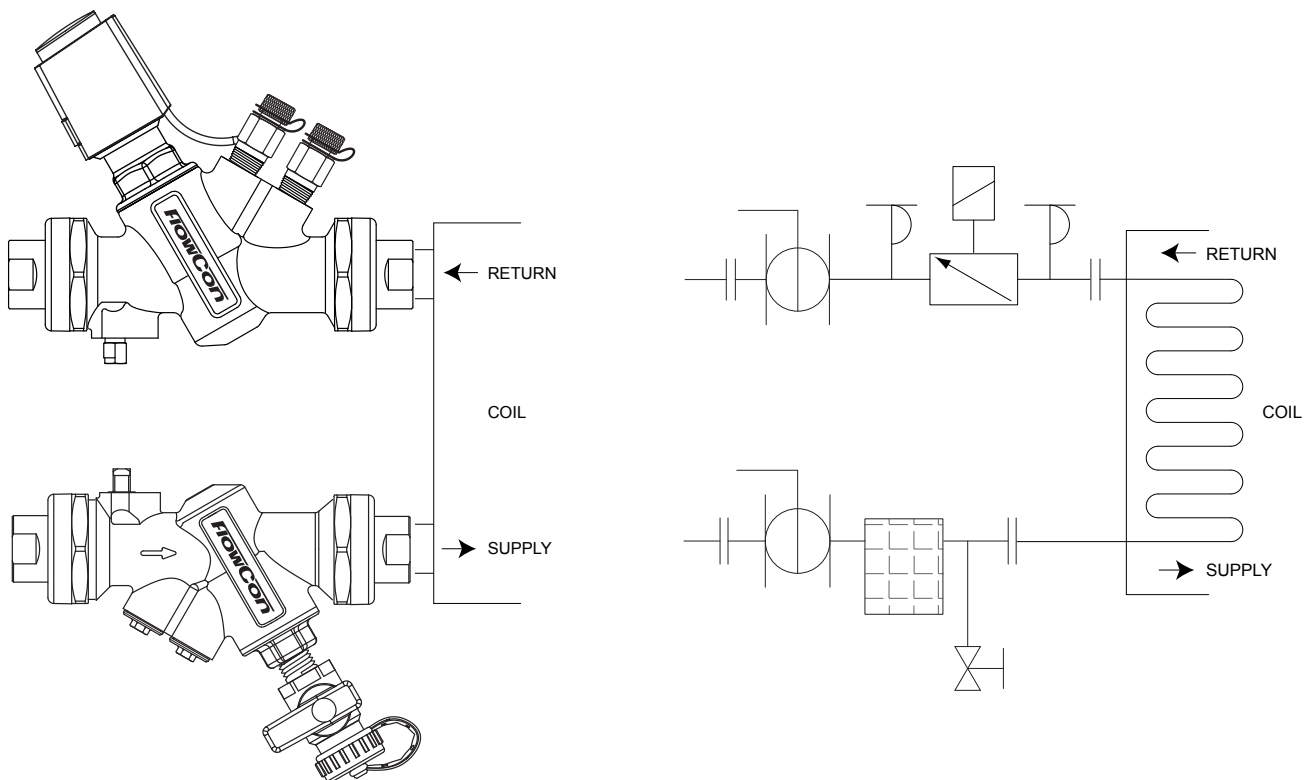

## UPDATES

For latest updates please see [www.flowcon.com](http://www.flowcon.com)

FlowCon International can accept no responsibility for possible errors in any printed material. All rights reserved.

# FlowCon EVC

## *Dynamic Balancing Valve with Temperature Control*



### SPECIFICATIONS

**Valve:**

Pressure rating:	1600 kPa / 230 psi
Temperature rating, media <sup>1</sup> :	-20°C to +120°C / -4°F to +248°F
Temperature rating, ambient:	0°C to +60°C / +32°F to +140°F
Material:	
- Insert:	Composite inserts: POM (Polyoxymethylene) E-JUST inserts: PSU (Polysulfone)
- Diaphragm:	Hydrogenated acrylonitrile-butadiene-rubber or EPDM depending on type
- Body:	Forged brass ASTM CuZn40Pb2
- EVC control insert:	Brass
- Union end connection (in-let):	Brass alloy ISO or NPT
- Seat plug and o-rings:	EPDM
Body tappings:	1/4" ISO
Maximum close off pressure:	400 kPaD / 58 psid
Shut off leakage:	IEC 60534-4 - Class V
Flow rate range:	0.0081-0.408 l/sec / 0.128-6.46 GPM

Note 1: Stated temperature rating is defined due to no external spindle condensation.

## SPECIFICATIONS (...continued)

### FlowCon Actuators:

FlowCon Actuator <sup>2</sup>	EV.0.2	EV.0.3	EV.0.4	EV.0.5	EV.1.3	EV.1.4
Supply voltage	24V AC -10%/+20% 50/60Hz	230V AC ±10% 50/60Hz	24V AC/DC -10%/+20% 50/60Hz	120V AC ±10% 50/60Hz	230V AC ±10% 50/60Hz	24V AC/DC -10%/+20% 50/60Hz
Power consumption	1.0 watt	1.0 watt	1.0 watt	1.0 watt	1.0 watt	1.0 watt
Control signal	0-10V DC normally closed <sup>3</sup>	ON/OFF normally closed <sup>3</sup>	ON/OFF normally closed <sup>3</sup>	ON/OFF normally closed <sup>3</sup>	ON/OFF normally closed <sup>3</sup>	ON/OFF normally closed <sup>3</sup>
Operation time	Approx. 2½ min	Approx. 4 min	Approx. 4 min	Approx. 4 min	Approx. 4 min	Approx. 4 min
Ambient temperature	0°C to +60°C	0°C to +60°C	0°C to +60°C	0°C to +60°C	0°C to +60°C	0°C to +60°C
Protection	IP54, class III	IP54, class II	IP54, class III	IP54, class II	IP54, class II	IP54
Cable	Plug-in, 1 meter	Fixed, 1 meter	Fixed, 1 meter	Fixed, 1 meter	Fixed, 1 meter	Fixed, 1 meter
Weight	0.127 kg <sup>4</sup>	0.116 kg <sup>4</sup>	0.116 kg <sup>4</sup>	0.116 kg <sup>4</sup>	0.166 kg <sup>4</sup>	0.166 kg <sup>4</sup>
Including end switch	No	No	No	No	Yes	Yes
Switching point	N/A	N/A	N/A	N/A	Approx. 2mm	Approx. 2mm
Switching capacity	N/A	N/A	N/A	N/A	230V AC 5A ohm resistive load 1A inductive load	24V AC 3A ohm resistive load 1A inductive load

Note 2: FlowCon warranty is voided using other actuators than supplied or recommended by FlowCon International.

Note 3: To ensure that the valve is in an open position during commission of the system, the actuator will be delivered in a normal open position and remain in this position until it is electrically operated first time.

Note 4: The weight includes actuator, adaptor ring and 1 meter cable.

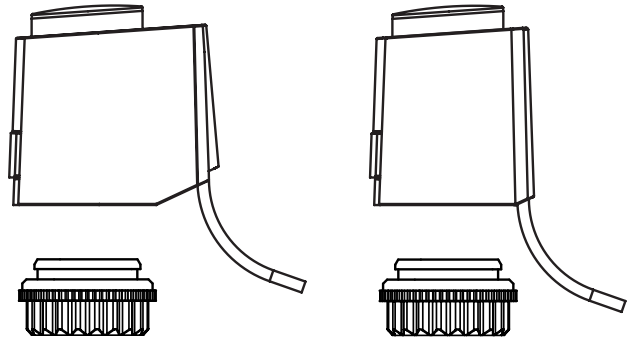

*FlowCon EV.0.2,  
EV.1.3 and EV.1.4  
Valve adaptor, grey*

*FlowCon EV.0.3,  
EV.0.4 and EV.0.5  
Valve adaptor, grey*

## DIMENSIONS AND WEIGHTS (NOMINAL) (measured in mm unless noted)

Valve model	Actuator model	Valve size	Insert size	L	H1	H2	H3 (with E-JUST)	Inlet end connections C <sup>5</sup>				Weight <sup>6</sup> (kgs.)	Kv <sup>7</sup> (m <sup>3</sup> /hr)
								Size	ISO female	ISO male	Sweat		
EVC.1	EV.0.2	15	20	115	107	67	79,5	15	22	24	20	0.90	1.9
EVC.2		20						22	25	20			
EVC.1	EV.0.3 EV.0.4 EV.0.5	15	20	115	103	67	79,5	15	22	24	20	0.90	1.9
EVC.2		20						22	25	20			
EVC.1	EV.1.3 EV.1.4	15	20	115	105	67	79,5	15	22	24	20	0.90	1.9
EVC.2		20						22	25	20			
								25	-	39	22	0.85	2.0

Note 5: Add end connection length to body length.

Note 6: The weight is without end connections and actuator, the weight of the actuator is available at page 2.

Note 7: For valve body.

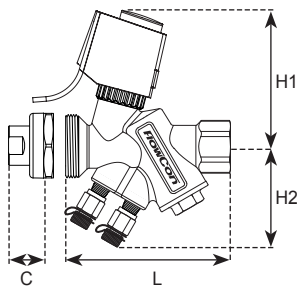

FlowCon EV.0.2, EV.1.3 and EV.1.4  
on FlowCon EVC

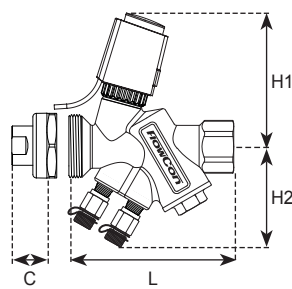

FlowCon EV.0.3, EV.0.4 and EV.0.5,  
on FlowCon EVC

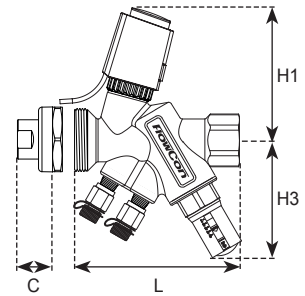

...with E-JUST

## MODEL NUMBER SELECTION<sup>8</sup>

**EVC .** \_\_\_\_\_

Insert type of actuator:  
**2**=EV.0.2   **3**=EV.0.3   **4**=EV.0.4   **5**=EV.1.3   **6**=EV.1.4   **7**=EV.0.5

Insert body size (OUTLET):  
**1**=female threaded 15mm   **2**=female threaded 20mm

Insert p/t plug requirement:  
**0**=taps open   **B**=pressure temperature plugs   **P**=taps plugged

Insert INLET union end connections - leave **blank** if no end connections required:

Body size	Female threaded	Male threaded	Sweat
Union end 15-25mm, 1/2"-1"	<b>E</b> =15mm=1/2" <b>F</b> =20mm=3/4"	<b>H</b> =15mm=1/2" <b>I</b> =20mm=3/4" <b>J</b> =25mm=1"	<b>K</b> =15mm <b>L</b> =18mm <b>M</b> =22mm

Insert connection standard:  
**I**=ISO   **N**=NPT

Insert a kPaD control range:  
**0** if no insert required  
**Y**=15-130 kPaD (20mm standard composite insert)  
 17-210 kPaD (20mm E-JUST red - white pawl)  
 17-210 kPaD (20mm E-JUST black or green - white pawl)  
**G**=30-400 kPaD (20mm standard composite insert)  
 30-400 kPaD (20mm E-JUST red - grey pawl)  
 35-400 kPaD (20mm E-JUST black or green - grey pawl)  
 (Determine from insert selection chart)

Insert automatic flow limiting insert code:  
**0** if no insert required   **Y**=grey   **R**=red   **U**=blue   **B**=black   **G**=green  
 (Determine from insert selection chart)

Insert insert dial setting/type:  
**1 to 8**=dial setting on standard composite insert  
**0**=standard pre-setting of 2 on standard composite insert  
**E**=E-JUST insert  
 (Determine from insert selection chart)

Example: EVC.4.2.B.H.I.G.U.5=EVC 20mm ISO female threaded body with p/t plugs, 24V ON/OFF actuator, 15mm ISO male threaded union end inlet and a G-type blue standard composite insert - pre-setting 5.

Note 8: Flow rate, color and dial setting of insert are indicated on label affixed to body.

## FLOW RATE SETTING - COMPOSITE INSERT - FOR VALVES DN15-DN25

20mm · 3/4" · composite insert · Y-type								
Pressure range, ΔP: 20-130 kPaD (15-130 kPaD)* · 2.9-18.9 psid (2.2-18.9 psid)*								
Nominal flow rate	Model no.			ABV1.Y.Y	ABV1.Y.R	ABV1.Y.U	ABV1.Y.B	ABV1.Y.G
	l/sec	l/hr	GPM	Grey*	Red	Blue	Black	Green
	0.0081	29.2	0.128	1				
	0.0133	47.9	0.211	2				
	0.0175	63.0	0.277	3				
	0.0222	79.9	0.352	4				
	0.0311	112	0.493	5				
	0.0353	127	0.560	6				
	0.0383	138	0.607	7				
	0.0431	155	0.683	8				
	0.0450	162	0.713				3	
	0.0575	207	0.911		4			
	0.0619	223	0.981			4		
	0.0669	241	1.06				4	
	0.0922	332	1.46		5			
	0.0978	352	1.55					1
	0.105	378	1.66		6			
	0.114	409	1.80		7			
	0.115	415	1.83			5		
	0.118	426	1.88					2
	0.119	430	1.89		8			
	0.136	489	2.15					3
	0.137	492	2.17			6		
	0.138	498	2.19					4
	0.146	524	2.31			7		
	0.146	526	2.32			8		
	0.155	557	2.45				5	
	0.176	635	2.80				6	
	0.180	647	2.85				7	
	0.193	695	3.06				8	
	0.231	830	3.66					5
	0.237	854	3.76					6
	0.253	909	4.00					7
	0.273	984	4.33					8

Accuracy: Greatest of either ±10% of controlled flow rate or 20 l/hr (0.0056 l/sec or 0.088 GPM).

20mm · 3/4" · composite insert · G-type								
Pressure range, ΔP: 40-400 kPaD (30-400 kPaD)* · 5.8-58 psid (4.4-58 psid)*								
Nominal flow rate	Model no.			ABV1.G.Y	ABV1.G.R	ABV1.G.U	ABV1.G.B	ABV1.G.G
	l/sec	l/hr	GPM	Grey*	Red	Blue	Black	Green
	0.0117	42.1	0.185	1				
	0.0189	68.0	0.300	2				
	0.0247	88.9	0.392	3				
	0.0325	117	0.515	4				
	0.0472	170	0.748	5				
	0.0528	190	0.837	6				
	0.0564	203	0.894			3		
	0.0597	215	0.946				3	
	0.0639	230	1.01	7				
	0.0694	250	1.10	8				
	0.0781	281	1.24		4			
	0.0908	327	1.44			4		
	0.0958	345	1.52				4	
	0.137	493	2.17		5			
	0.147	529	2.33					1
	0.161	581	2.56		6			
	0.173	624	2.75		7			
	0.181	652	2.87			5		
	0.181	653	2.88		8			
	0.186	670	2.95					2
	0.210	755	3.32					3
	0.216	779	3.43			6		
	0.218	785	3.46			7		
	0.220	792	3.49			8		
	0.237	853	3.75				5	
	0.241	869	3.83					4
	0.266	957	4.21				6	
	0.269	968	4.26				7	
	0.277	998	4.39				8	
	0.365	1320	5.79					5
	0.369	1330	5.85					6
	0.392	1410	6.21					7
	0.408	1470	6.46					8

Accuracy: Greatest of either ±10% of controlled flow rate or 20 l/hr (0.0056 l/sec or 0.088 GPM).

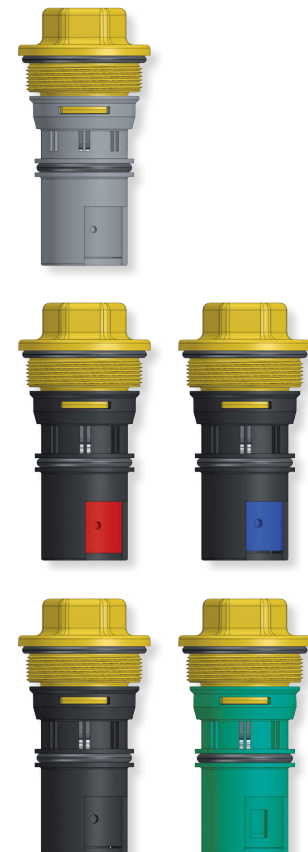

## FLOW RATE SETTING - E-JUST INSERT - FOR VALVES DN15-DN25

20mm · 3/4" · E-JUST · Y-type · White pawl					
Pressure range, ΔP: 17-210 kPaD · 2.5-30 psid					
Nominal flow rate	Model no.			E-JUST1.Y.B	E-JUST1.Y.G
	l/sec	l/hr	GPM	Black	Green
				Setting	Setting
	0.0278	100	0.440	1.0	
	0.0299	108	0.475	1.1	
	0.0321	116	0.509	1.2	
	0.0343	123	0.543	1.3	
	0.0364	131	0.578	1.4	
	0.0386	139	0.612	1.5	
	0.0408	147	0.646	1.6	
	0.0429	155	0.681	1.7	
	0.0436	157	0.691		1.0
	0.0451	162	0.715	1.8	
	0.0468	168	0.741		1.1
	0.0473	170	0.749	1.9	
	0.0494	178	0.784	2.0	
	0.0499	180	0.791		1.2
	0.0516	186	0.818	2.1	
	0.0530	191	0.841		1.3
	0.0538	194	0.852	2.2	
	0.0559	201	0.887	2.3	
	0.0562	202	0.890		1.4
	0.0581	209	0.921	2.4	
	0.0593	214	0.940		1.5
	0.0603	217	0.955	2.5	
	0.0624	225	0.990	2.6	1.6
	0.0646	233	1.02	2.7	
	0.0656	236	1.04		1.7
	0.0668	240	1.06	2.8	
	0.0687	247	1.09		1.8
	0.0689	248	1.09	2.9	
	0.0711	256	1.13	3.0	
	0.0719	259	1.14		1.9
	0.0733	264	1.16	3.1	
	0.0750	270	1.19		2.0
	0.0754	272	1.20	3.2	
	0.0776	279	1.23	3.3	
	0.0781	281	1.24		2.1
	0.0798	287	1.26	3.4	
	0.0813	293	1.29		2.2
	0.0819	295	1.30	3.5	
	0.0841	303	1.33	3.6	
	0.0844	304	1.34		2.3
	0.0863	311	1.37	3.7	
	0.0876	315	1.39		2.4
	0.0884	318	1.40	3.8	

Continue next column...

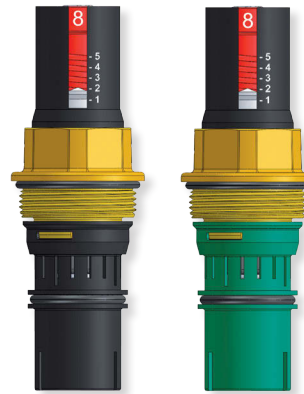

20mm · 3/4" · E-JUST · Y-type · White pawl					
Pressure range, ΔP: 17-210 kPaD · 2.5-30 psid					
Nominal flow rate	Model no.			E-JUST1.Y.B	E-JUST1.Y.G
	l/sec	l/hr	GPM	Black	Green
				Setting	Setting
	0.0906	326	1.44	3.9	
	0.0907	327	1.44		2.5
	0.0928	334	1.47	4.0	
	0.0938	338	1.49		2.6
	0.0949	342	1.50	4.1	
	0.0970	349	1.54		2.7
	0.0971	350	1.54	4.2	
	0.0993	357	1.57	4.3	
	0.100	360	1.59		2.8
	0.101	365	1.61	4.4	
	0.103	372	1.64		2.9
	0.104	373	1.64	4.5	
	0.106	381	1.68	4.6	
	0.106	383	1.69		3.0
	0.108	389	1.71	4.7	
	0.110	394	1.74		3.1
	0.110	396	1.75	4.8	
	0.112	404	1.78	4.9	
	0.113	406	1.79		3.2
	0.114	412	1.81	5.0	
	0.116	417	1.84		3.3
	0.119	428	1.89		3.4
	0.122	440	1.94		3.5
	0.125	451	1.98		3.6
	0.128	462	2.03		3.7
	0.132	473	2.08		3.8
	0.135	485	2.13		3.9
	0.138	496	2.18		4.0
	0.141	507	2.23		4.1
	0.144	519	2.28		4.2
	0.147	530	2.33		4.3
	0.150	541	2.38		4.4
	0.153	553	2.43		4.5
	0.157	564	2.48		4.6
	0.160	575	2.53		4.7
	0.163	586	2.58		4.8
	0.166	598	2.63		4.9
	0.169	609	2.68		5.0

Accuracy: Greatest of either ±5% of controlled flow rate or ±2% of maximum flow rate

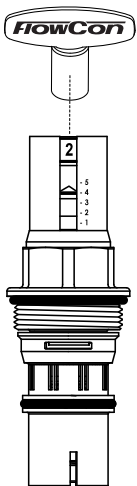

Use the FlowCon adjustment key (part number ACC0001) for adjusting the flow rate.

A setting of 4.2 corresponds to a flow rate of 0.144 l/sec for the 20mm green insert, range 17-210 kPaD.

## FLOW RATE SETTING - E-JUST INSERT - FOR VALVES DN15-DN25 (continued)

20mm · 3/4" · E-JUST · Y-type · White pawl				
Pressure range. ΔP: 17-200 kPaD · 2.5-29 psid				
Nominal flow rate	Model no.			E-JUST1.Y.R
	l/sec	l/hr	GPM	Red
				Setting
	0.0767	276	1.22	1.0
	0.0813	293	1.29	1.1
	0.0860	310	1.36	1.2
	0.0907	326	1.44	1.3
	0.0953	343	1.51	1.4
	0.100	360	1.58	1.5
	0.105	377	1.66	1.6
	0.109	393	1.73	1.7
	0.114	410	1.80	1.8
	0.118	426	1.88	1.9
	0.123	443	1.95	2.0
	0.128	459	2.02	2.1
	0.132	475	2.09	2.2
	0.136	491	2.16	2.3
	0.141	507	2.23	2.4
	0.145	523	2.30	2.5
	0.150	539	2.37	2.6
	0.154	554	2.44	2.7
	0.158	569	2.51	2.8
	0.162	584	2.57	2.9
	0.166	599	2.64	3.0
	0.170	614	2.70	3.1
	0.174	628	2.76	3.2
	0.178	642	2.83	3.3
	0.182	655	2.89	3.4
	0.186	669	2.94	3.5
	0.189	682	3.00	3.6
	0.193	695	3.06	3.7
	0.196	707	3.11	3.8
	0.200	719	3.17	3.9
	0.203	731	3.22	4.0
	0.206	742	3.27	4.1
	0.209	753	3.32	4.2
	0.212	764	3.36	4.3
	0.215	774	3.41	4.4
	0.218	784	3.45	4.5
	0.220	793	3.49	4.6
	0.223	802	3.53	4.7
	0.225	810	3.57	4.8
	0.227	818	3.60	4.9
	0.229	825	3.60	5.0

Accuracy: Greatest of either ±5% of controlled flow rate or ±2% of maximum flow rate

20mm · 3/4" · E-JUST · G-type · Grey pawl				
Pressure range. ΔP: 30-400 kPaD · 4.4-58 psid				
Nominal flow rate	Model no.			E-JUST1.G.R
	l/sec	l/hr	GPM	Red
				Setting
	0.113	406	1.79	1.0
	0.119	427	1.88	1.1
	0.125	449	1.98	1.2
	0.131	470	2.07	1.3
	0.137	492	2.17	1.4
	0.143	513	2.26	1.5
	0.149	535	2.36	1.6
	0.155	556	2.45	1.7
	0.161	578	2.54	1.8
	0.167	599	2.64	1.9
	0.172	621	2.73	2.0
	0.178	642	2.83	2.1
	0.184	664	2.92	2.2
	0.190	685	3.02	2.3
	0.196	707	3.11	2.4
	0.202	728	3.21	2.5
	0.208	750	3.30	2.6
	0.214	771	3.40	2.7
	0.220	793	3.49	2.8
	0.226	814	3.59	2.9
	0.232	836	3.68	3.0
	0.238	857	3.78	3.1
	0.244	879	3.87	3.2
	0.250	900	3.96	3.3
	0.256	922	4.06	3.4
	0.262	943	4.15	3.5
	0.268	965	4.25	3.6
	0.274	987	4.34	3.7
	0.280	1010	4.44	3.8
	0.286	1030	4.53	3.9
	0.292	1050	4.63	4.0
	0.298	1070	4.72	4.1
	0.304	1090	4.82	4.2
	0.310	1120	4.91	4.3
	0.316	1140	5.01	4.4
	0.322	1160	5.10	4.5
	0.328	1180	5.20	4.6
	0.334	1200	5.29	4.7
	0.340	1220	5.38	4.8
	0.346	1240	5.48	4.9
	0.352	1270	5.57	5.0

Accuracy: Greatest of either ±5% of controlled flow rate or ±2% of maximum flow rate

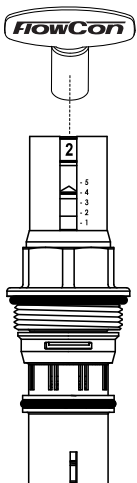
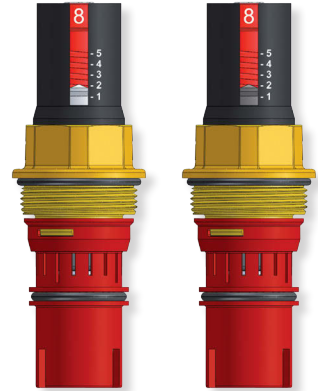

Use the FlowCon adjustment key (part number ACC0001) for adjusting the flow rate.

A setting of 4.2 corresponds to a flow rate of 0.304 l/sec for the 20mm red insert, range 30-400 kPaD.

## FLOW RATE SETTING - E-JUST INSERT - FOR VALVES DN15-DN25 (continued)

20mm · 3/4" · E-JUST · G-type · Grey pawl					
Pressure range, ΔP: 35-400 kPaD · 5.1-58 psid					
Nominal flow rate	Model no.			E-JUST1.G.B	E-JUST1.G.G
	l/sec	l/hr	GPM	Black	Green
				Setting	Setting
	0.0383	138	0.607	1.0	
	0.0416	150	0.660	1.1	
	0.0449	162	0.712	1.2	
	0.0483	174	0.765	1.3	
	0.0516	186	0.817	1.4	
	0.0549	198	0.870	1.5	
	0.0582	210	0.922	1.6	
	0.0615	221	0.975	1.7	
	0.0648	233	1.03	1.8	
	0.0660	238	1.05		1.0
	0.0681	245	1.08	1.9	
	0.0706	254	1.12		1.1
	0.0714	257	1.13	2.0	
	0.0748	269	1.18	2.1	
	0.0751	271	1.19		1.2
	0.0781	281	1.24	2.2	
	0.0797	287	1.26		1.3
	0.0814	293	1.29	2.3	
	0.0843	304	1.34		1.4
	0.0847	305	1.34	2.4	
	0.0880	317	1.40	2.5	
	0.0889	320	1.41		1.5
	0.0913	329	1.45	2.6	
	0.0934	336	1.48		1.6
	0.0946	341	1.50	2.7	
	0.0979	353	1.55	2.8	
	0.0980	353	1.55		1.7
	0.101	365	1.61	2.9	
	0.103	369	1.63		1.8
	0.105	377	1.66	3.0	
	0.107	386	1.70		1.9
	0.108	388	1.71	3.1	
	0.111	400	1.76	3.2	
	0.112	402	1.77		2.0
	0.115	412	1.82	3.3	
	0.116	419	1.84		2.1
	0.118	424	1.87	3.4	
	0.121	435	1.92		2.2
	0.121	436	1.92	3.5	
	0.124	448	1.97	3.6	
	0.125	452	1.99		2.3
	0.128	460	2.03	3.7	
	0.130	468	2.06		2.4
	0.131	472	2.08	3.8	

Continue next column...

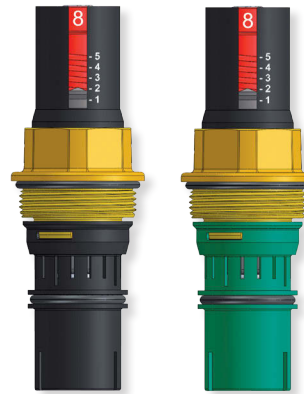

20mm · 3/4" · E-JUST · G-type · Grey pawl					
Pressure range, ΔP: 35-400 kPaD · 5.1-58 psid					
Nominal flow rate	Model no.			E-JUST1.G.B	E-JUST1.G.G
	l/sec	l/hr	GPM	Black	Green
				Setting	Setting
	0.134	484	2.13	3.9	
	0.135	485	2.13		2.5
	0.138	496	2.18	4.0	
	0.139	501	2.21		2.6
	0.141	508	2.24	4.1	
	0.144	517	2.28		2.7
	0.144	520	2.29	4.2	
	0.148	532	2.34	4.3	
	0.148	534	2.35		2.8
	0.151	544	2.39	4.4	
	0.153	550	2.42		2.9
	0.154	556	2.45	4.5	
	0.157	567	2.50		3.0
	0.158	567	2.50	4.6	
	0.161	579	2.55	4.7	
	0.162	583	2.57		3.1
	0.164	591	2.60	4.8	
	0.167	600	2.64		3.2
	0.168	603	2.66	4.9	
	0.171	615	2.71	5.0	
	0.171	616	2.71		3.3
	0.176	633	2.79		3.4
	0.180	649	2.86		3.5
	0.185	666	2.93		3.6
	0.189	682	3.00		3.7
	0.194	699	3.08		3.8
	0.199	715	3.15		3.9
	0.203	731	3.22		4.0
	0.208	748	3.29		4.1
	0.212	764	3.37		4.2
	0.217	781	3.44		4.3
	0.221	797	3.51		4.4
	0.226	814	3.58		4.5
	0.231	830	3.66		4.6
	0.235	847	3.73		4.7
	0.240	863	3.80		4.8
	0.244	880	3.87		4.9
	0.249	896	3.95		5.0

Accuracy: Greatest of either ±5% of controlled flow rate or ±2% of maximum flow rate

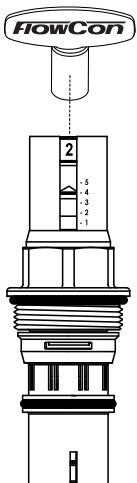

Use the FlowCon adjustment key (part number ACC0001) for adjusting the flow rate.

A setting of 4.2 corresponds to a flow rate of 0.212 l/sec for the 20mm green insert, range 35-400 kPaD.

## ACCESSORIES

- P/t plugs: 2 x ACC00101
- Blind cap: ACC0080 (cap without an insert for flushing out the system)
- Adjustment key: ACC0001 (key for adjusting the flow rate on E-JUST inserts).

## GENERAL DESCRIPTION

The standard actuators available for the FlowCon EVC valve are thermal actuators that operate ON/OFF on 24V AC/DC, 120V AC and 230V AC/DC or modulating on 24V AC respectively. ON/OFF actuators are available with end switches which can be used for controlling the fan in priority to the open position of the valve.

The EVC valves provide temperature control and dynamic balancing for use in cooling ceilings, fan coil units in air-condition or as zone valve in heating systems.

## GENERAL SPECIFICATIONS

### 1. AUTOMATIC BALANCING AND TEMPERATURE CONTROL VALVES - FLOWCON EVC

- 1.1. Contractor shall install balancing / temperature valves where indicated in drawings.
- 1.2. The valve shall consist of dynamic, accessible, adjustable flow limiting device and integral thermal actuated two-way control valve.

### 2. VALVE ACTUATOR

- 2.1. Actuator shall provide a visual indication of the valve position.
- 2.2. The valve shall be closing when the actuator is not powered.
- 2.3. The valve shall withstand a shut off pressure of at least 400 kPa without allowing internal leakage.
- 2.4. The seat plug shall be manufactured of EPDM rubber.
- 2.5. The packing box for sealing the stem shall be removable with the system in operation, without allowing external leakage.

### 3. VALVE HOUSING

- 3.1. Valve housing shall consist of forged brass ASTM CuZn40Pb2, rated at no less than 1600 kPa static pressure and +120°C.
- 3.2. Valve housing shall be permanently marked to show direction of flow.
- 3.3. Valve housing shall be union end constructed with a range of pipe connections available for the appropriate pipe size.
- 3.4. Housing shall be configured for flow regulation unit accessibility.
- 3.5. Optional dual pressure/temperature test plugs for verifying accuracy of flow performance shall be available for all valve sizes.

### 4.a. FLOW REGULATOR / AUTOMATIC BALANCING UNIT / COMPOSITE INSERT

- 4.a.1. Flow regulation unit assembly shall be manufactured of polyoxymethylene with a hydrogenated acrylnitrile-butadiene rubber or EPDM diaphragm and stainless steel 18-8 spring.
- 4.a.2. Flow regulation unit shall be readily accessible for change-out or maintenance.
- 4.a.3. Flow regulation unit shall be adjustable to 1 of 8 different flow rates; shall be available in 2 different kPaD operational ranges; minimum range shall be capable of being activated by minimum 15 kPaD. Further, the flow regulation unit shall be capable of controlling the flow within  $\pm 10\%$  of rated flow rate or 20l/hr.
- 4.a.4. Identification tags shall be available for all valves; tags shall be indelibly marked with flow rate, color and dial setting.

## GENERAL SPECIFICATIONS (continued)

OR...

### 4.b. FLOW REGULATOR / AUTOMATIC BALANCING UNIT / E-JUST INSERT

- 4.b.1. Flow regulation unit assembly shall be manufactured of polysulfone with a hydrogenated acrylonitrile-butadiene rubber or EPDM diaphragm and stainless steel 18-8 spring.
- 4.b.2. Flow regulation unit shall be readily accessible for change-out or maintenance.
- 4.b.3. Flow regulation unit shall be adjustable with the valve in-line and the system in operation.
- 4.b.4. Flow regulation unit shall be externally adjustable to 1 of 41 different flow rates; shall be available in 4 different kPaD operational ranges for DN15/20/25; minimum range shall be capable of being activated by minimum 17 kPaD. Further, the flow regulation unit shall be capable of controlling flow within  $\pm 5\%$  of rated flow or  $\pm 2\%$  of maximum flow.
- 4.b.5. Identification tags shall be available for all valves; tags shall be indelibly marked with flow rate, color and dial setting.

## APPLICATION AND SCHEMATIC EXAMPLE

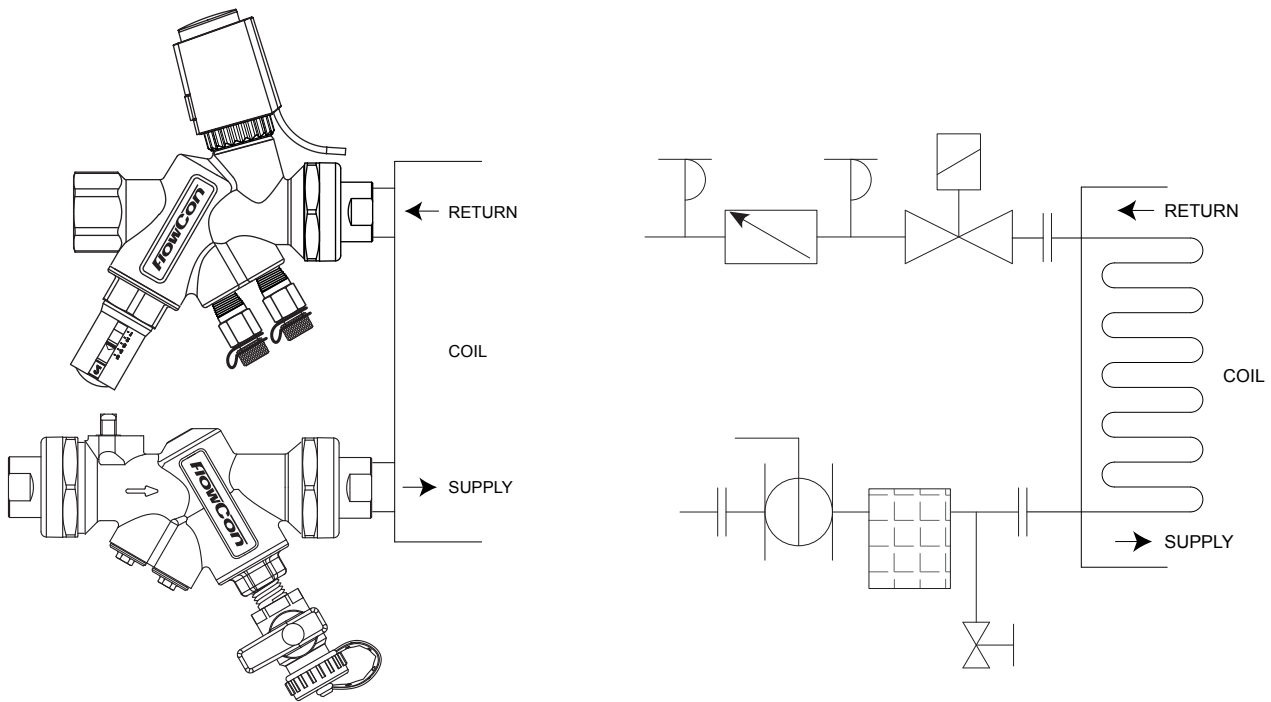

## UPDATES

For latest updates please see [www.flowcon.com](http://www.flowcon.com)

FlowCon International can accept no responsibility for possible errors in any printed material.  
All rights reserved.

# FlowCon ABM 15-40mm

## Balanced Temperature Control Valve

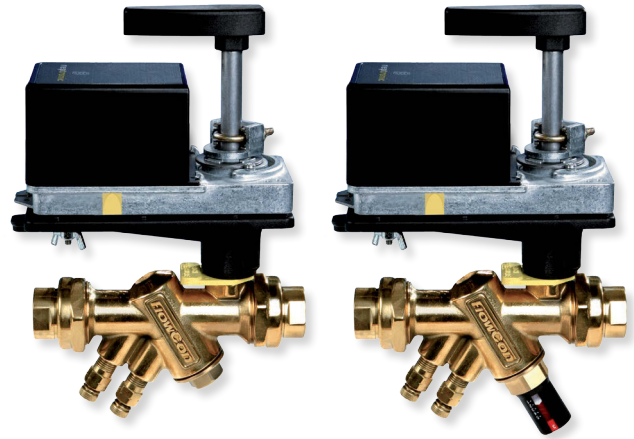

### SPECIFICATIONS

Pressure rating:	2500 kPa / 360 psi
Temperature rating, media:	-20°C to +120°C / -4°F to +248°F
Temperature rating, ambient:	-20°C to +50°C / -4°F to +122°F
Materials:	
- Insert:	Composite inserts: POM (Polyoxymethylene) E-JUST inserts: PSU (Polysulfone)
- Diaphragm:	Hydrogenated acrylonitrile-butadiene-rubber or EPDM depending on type
- Body:	Forged brass ASTM CuZn40Pb2
- Ball valve:	Chemically nickel plated brass ball
- OPTIMIZER insert:	NORYL, glass filled polymer
- Ball seals:	Reinforced teflon (PTFE)
- Union end connection:	Brass alloy ISO or NPT
- Stem seals and o-rings:	EPDM
Body tappings:	1/4" ISO
Max. close off pressure:	700 kPa / 101.5 psi
Flow rate range:	0.0081-1.43 l/sec (standard composite insert) 0.0278-1.62 l/sec (E-JUST insert)

**DIMENSIONS AND WEIGHTS (NOMINAL) (measured in mm unless noted)**

Model no.	Valve size	Insert size	Optimizer®	Kvs <sup>1</sup> (m <sup>3</sup> /hr)	L	H1	H2	H3	End connections C <sup>2</sup>			Weight (kgs.) w/o end conn.	Kv <sup>3</sup> (m <sup>3</sup> /hr)
									ISO female	ISO male	Sweat		
ABM1	15	20	1	0.345	122	186	66	78	22	24	20	1.55	2.6
			3	1.121									
			5	3.190									
			6 <sup>4</sup>	5.345									
	20		1	0.345									
			3	1.121									
			5	3.707									
			6 <sup>4</sup>	6.379									
	25		1	0.259									
			3	1.121									
			5	3.276									
			6 <sup>4</sup>	5.948									
ABM2	25	40	3	3.621	162	192	86	102	35	40	34	3.25	12.5
			4	6.121									
			1	9.052									
			2 <sup>4</sup>	12.414									
	32		3	3.448									
			4	6.293									
			1	8.966									
			2 <sup>4</sup>	12.586									
	40		3	3.448									
			4	6.293									
			1	8.793									
			2 <sup>4</sup>	12.500									

Note 1: For ball and Optimizer® insert.  
 Note 2: Add end connection length to body length.  
 Note 3: For valve body.  
 Note 4: Ball without Optimizer® insert.

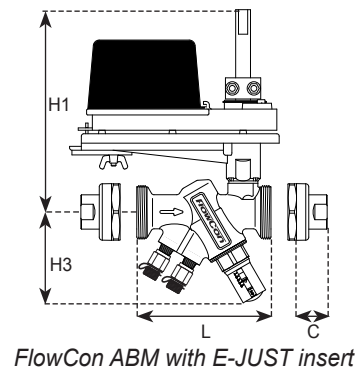
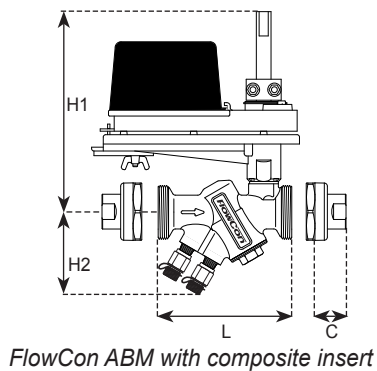

## MODEL NUMBER SELECTION<sup>5</sup>

**ABM .**

Insert body size:

**1**=ABM1 body (15/20/25mm) **2**=ABM2 body (25/32/40mm)

Insert Optimizer® insert:

Insert **1, 2, 3, 4, 5** or **6**  
(Determine from dimension chart)

Insert p/t plug requirement:

**0**=taps open **B**=pressure temperature plugs **P**=taps plugged

Insert power supply, actuator:

**0**=if no actuator required

**1**=24V 2-position or 3-point floating (without end switches) (BBTS1000)

**2**=240V 2-position or 3-point floating (without end switches) (BBTHV1200A)

**3**=24V modulating (without end switches) (BBMS2000)

**4**=24V 2-position or 3-point floating incl. auxiliary switches (BBTS1021)

**5**=240V 2-position or 3-point floating incl. auxiliary switches (BBTHV1221A)

**6**=24V modulating incl. auxiliary switches (BBMS2021)

Insert inlet x outlet union end connections:

Body size	Female threaded	Male treaded	Sweat
Union end 15-20mm, 1/2"-1"	<b>E</b> =15mm=1/2" <b>F</b> =20mm=3/4"	<b>H</b> =15mm=1/2" <b>I</b> =20mm=3/4" <b>J</b> =25mm=1"	<b>K</b> =15mm <b>L</b> =18mm <b>M</b> =22mm
Union end 25-40mm, 1"-1 1/2"	<b>G</b> =25mm=1" <b>P</b> =32mm=1 1/4" <b>Q</b> =40mm=1 1/2"	<b>J</b> =25mm=1" <b>S</b> =32mm=1 1/4" <b>T</b> =40mm=1 1/2"	<b>N</b> =28mm <b>W</b> =35mm

Insert connection standard:

**I**=ISO **N**=NPT

Insert a kPaD control range:

**0** if no insert required

**Y**= 15-130 kPaD (20mm standard composite insert)

17-200 kPaD (20mm E-JUST red - white pawl)

17-210 kPaD (20mm E-JUST black or green - white pawl)

17-400 kPaD (40mm E-JUST - white pawl)

**G**=30-400 kPaD (20mm standard composite insert)

30-400 kPaD (20mm E-JUST red - grey pawl)

35-400 kPaD (20mm E-JUST black or green - grey pawl)

**X**= 15-130 kPaD (40mm standard composite insert)

**C**= 22-300 kPaD (40mm standard composite insert)

**D**= 30-410 kPaD (40mm standard composite insert)

(Determine from insert selection chart)

Insert automatic flow limiting insert code:

**0** if no insert required **Y**=grey **R**=red **U**=blue **B**=black **G**=green **W**=white

(Determine from insert selection chart)

Insert insert dial setting/type:

**1 to 8**=dial setting on standard composite insert

**0**=standard pre-setting of 2 on standard composite insert

**E**=E-JUST insert

(Determine from insert selection chart)

Example: ABM.1.1.B.1.E.E.I.Y.Y.0=ABM1-body with Optimizer® insert 1, p/t plugs and 24V actuator, 15mm ISO female threaded union connections and a Y-type grey standard composite insert - pre-setting 2.

Note 5: Flow rate, color and dial setting of insert are indicated on label affixed to body.

## EQUAL PERCENTAGE CHARACTERISTIC

The Flow Optimizer® provides equal percentage control so that the heat output at the coil is linear when compared to the open area of the ball.

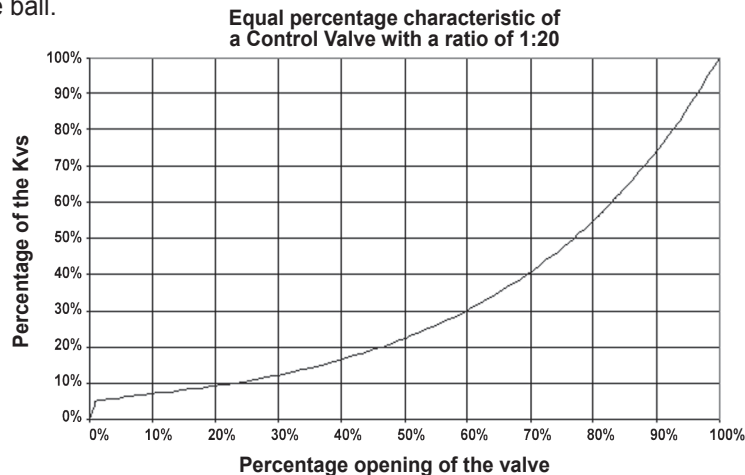

## FLOW RATE SETTING - COMPOSITE INSERT - FOR VALVES DN15-DN25 SMALL

20mm · 3/4" · composite insert · Y-type								
Pressure range, ΔP: 20-130 kPaD (15-130 kPaD)* · 2.9-18.9 psid (2.2-18.9 psid)*								
	Model no.			ABV1.Y.Y	ABV1.Y.R	ABV1.Y.U	ABV1.Y.B	ABV1.Y.G
	l/sec	l/hr	GPM	Grey*	Red	Blue	Black	Green
Nominal flow rate	0.0081	29.2	0.128	1				
	0.0133	47.9	0.211	2				
	0.0175	63.0	0.277	3				
	0.0222	79.9	0.352	4				
	0.0311	112	0.493	5				
	0.0353	127	0.560	6				
	0.0383	138	0.607	7				
	0.0431	155	0.683	8				
	0.0450	162	0.713					3
	0.0575	207	0.911		4			
	0.0619	223	0.981			4		
	0.0669	241	1.06				4	
	0.0922	332	1.46		5			
	0.0978	352	1.55					1
	0.105	378	1.66		6			
	0.114	409	1.80		7			
	0.115	415	1.83			5		
	0.118	426	1.88					2
	0.119	430	1.89		8			
	0.136	489	2.15					3
	0.137	492	2.17			6		
	0.138	498	2.19					4
	0.146	524	2.31			7		
	0.146	526	2.32			8		
	0.155	557	2.45				5	
	0.176	635	2.80				6	
	0.180	647	2.85				7	
	0.193	695	3.06				8	
	0.231	830	3.66					5
	0.237	854	3.76					6
0.253	909	4.00					7	
0.273	984	4.33					8	

Accuracy: Greatest of either ±10% of controlled flow rate or 20 l/hr (0.0056 l/sec or 0.088 GPM).

20mm · 3/4" · composite insert · G-type								
Pressure range, ΔP: 40-400 kPaD (30-400 kPaD)* · 5.8-58 psid (4.4-58 psid)*								
	Model no.			ABV1.G.Y	ABV1.G.R	ABV1.G.U	ABV1.G.B	ABV1.G.G
	l/sec	l/hr	GPM	Grey*	Red	Blue	Black	Green
Nominal flow rate	0.0117	42.1	0.185	1				
	0.0189	68.0	0.300	2				
	0.0247	88.9	0.392	3				
	0.0325	117	0.515	4				
	0.0472	170	0.748	5				
	0.0528	190	0.837	6				
	0.0564	203	0.894			3		
	0.0597	215	0.946				3	
	0.0639	230	1.01	7				
	0.0694	250	1.10	8				
	0.0781	281	1.24		4			
	0.0908	327	1.44			4		
	0.0958	345	1.52				4	
	0.137	493	2.17		5			
	0.147	529	2.33					1
	0.161	581	2.56		6			
	0.173	624	2.75		7			
	0.181	652	2.87			5		
	0.181	653	2.88		8			
	0.186	670	2.95					2
	0.210	755	3.32					3
	0.216	779	3.43			6		
	0.218	785	3.46			7		
	0.220	792	3.49			8		
	0.237	853	3.75				5	
	0.241	869	3.83					4
	0.266	957	4.21				6	
	0.269	968	4.26				7	
	0.277	998	4.39				8	
	0.365	1320	5.79					5
0.369	1330	5.85					6	
0.392	1410	6.21					7	
0.408	1470	6.46					8	

Accuracy: Greatest of either ±10% of controlled flow rate or 20 l/hr (0.0056 l/sec or 0.088 GPM).



## FLOW RATE SETTING - COMPOSITE INSERT - FOR VALVES DN25 LARGE-DN40

40mm · 1 1/2" · composite insert · X-type					
Pressure range, ΔP: 15-130 kPaD · 2.2-18.9 psid					
Nominal flow rate	Model no.		ABV2.X.W	ABV2.X.R	
	I/sec	I/hr	GPM	White	Red
	0.17	612	2.69	1	
	0.23	828	3.64	2	
	0.26	936	4.12		1
	0.33	1190	5.23	3	
	0.38	1370	6.02	4	
	0.39	1400	6.18		2
	0.48	1730	7.61	5	3
	0.54	1940	8.56	6	
	0.62	2230	9.83	7	
	0.63	2270	9.99		4
0.66	2380	10.5	8		
0.67	2410	10.6		5	
0.76	2740	12.0		6	
0.85	3060	13.5		7	



Accuracy: Greatest of either ±10% of controlled flow rate or 20 l/hr (0.0056 l/sec or 0.088 GPM).

40mm · 1 1/2" · composite insert · C-type					
Pressure range, ΔP: 22-300 kPaD · 3.2-43.5 psid					
Nominal flow rate	Model no.		ABV2.C.W	ABV2.C.R	
	I/sec	I/hr	GPM	White	Red
	0.23	828	3.65	1	
	0.31	1120	4.91	2	
	0.38	1370	6.02		1
	0.42	1510	6.66	3	
	0.47	1690	7.45	4	
	0.50	1800	7.93		2
	0.60	2160	9.51	5	
	0.64	2300	10.1		3
	0.68	2450	10.8	6	
	0.78	2810	12.4	7	
	0.83	2990	13.2		4
	0.84	3020	13.3	8	
	0.90	3240	14.3		5
1.07	3850	17.0		6	
1.17	4210	18.5		7	
1.21	4360	19.2		8	

Accuracy: Greatest of either ±10% of controlled flow rate or 20 l/hr (0.0056 l/sec or 0.088 GPM).

40mm · 1 1/2" · composite insert · D-type					
Pressure range, ΔP: 30-410 kPaD · 4.4-59.5 psid					
Nominal flow rate	Model no.		ABV2.D.W	ABV2.D.R	
	I/sec	I/hr	GPM	White	Red
	0.27	972	4.28	1	
	0.36	1300	5.71	2	
	0.44	1580	6.97		1
	0.52	1870	8.24	3	
	0.58	2090	9.19	4	
	0.60	2160	9.51		2
	0.74	2660	11.7	5	
	0.76	2740	12.0		3
	0.83	2990	13.2	6	
	0.93	3350	14.7	7	
	0.99	3560	15.7	8	4
	1.07	3850	17.0		5
1.28	4610	20.3		6	
1.39	5000	22.0		7	
1.43	5150	22.7		8	

Accuracy: Greatest of either ±10% of controlled flow rate or 20 l/hr (0.0056 l/sec or 0.088 GPM).

## FLOW RATE SETTING - E-JUST INSERT - FOR VALVES DN15-DN25 SMALL

20mm · 3/4" · E-JUST · Y-type · White pawl					
Pressure range, ΔP: 17-210 kPaD · 2.5-30 psid					
Nominal flow rate	Model no.			E-JUST1.Y.B	E-JUST1.Y.G
	l/sec	l/hr	GPM	Black	Green
				Setting	Setting
	0.0278	100	0.440	1.0	
	0.0299	108	0.475	1.1	
	0.0321	116	0.509	1.2	
	0.0343	123	0.543	1.3	
	0.0364	131	0.578	1.4	
	0.0386	139	0.612	1.5	
	0.0408	147	0.646	1.6	
	0.0429	155	0.681	1.7	
	0.0436	157	0.691		1.0
	0.0451	162	0.715	1.8	
	0.0468	168	0.741		1.1
	0.0473	170	0.749	1.9	
	0.0494	178	0.784	2.0	
	0.0499	180	0.791		1.2
	0.0516	186	0.818	2.1	
	0.0530	191	0.841		1.3
	0.0538	194	0.852	2.2	
	0.0559	201	0.887	2.3	
	0.0562	202	0.890		1.4
	0.0581	209	0.921	2.4	
	0.0593	214	0.940		1.5
	0.0603	217	0.955	2.5	
	0.0624	225	0.990	2.6	1.6
	0.0646	233	1.02	2.7	
	0.0656	236	1.04		1.7
	0.0668	240	1.06	2.8	
	0.0687	247	1.09		1.8
	0.0689	248	1.09	2.9	
	0.0711	256	1.13	3.0	
	0.0719	259	1.14		1.9
	0.0733	264	1.16	3.1	
	0.0750	270	1.19		2.0
	0.0754	272	1.20	3.2	
	0.0776	279	1.23	3.3	
	0.0781	281	1.24		2.1
	0.0798	287	1.26	3.4	
	0.0813	293	1.29		2.2
	0.0819	295	1.30	3.5	
	0.0841	303	1.33	3.6	
	0.0844	304	1.34		2.3
	0.0863	311	1.37	3.7	
	0.0876	315	1.39		2.4
	0.0884	318	1.40	3.8	

Continue next column...

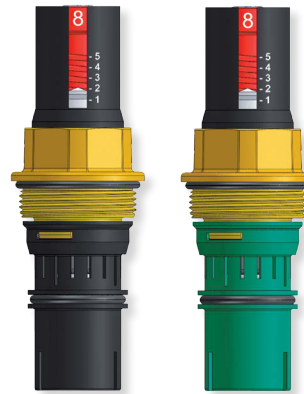

20mm · 3/4" · E-JUST · Y-type · White pawl					
Pressure range, ΔP: 17-210 kPaD · 2.5-30 psid					
Nominal flow rate	Model no.			E-JUST1.Y.B	E-JUST1.Y.G
	l/sec	l/hr	GPM	Black	Green
				Setting	Setting
	0.0906	326	1.44	3.9	
	0.0907	327	1.44		2.5
	0.0928	334	1.47	4.0	
	0.0938	338	1.49		2.6
	0.0949	342	1.50	4.1	
	0.0970	349	1.54		2.7
	0.0971	350	1.54	4.2	
	0.0993	357	1.57	4.3	
	0.100	360	1.59		2.8
	0.101	365	1.61	4.4	
	0.103	372	1.64		2.9
	0.104	373	1.64	4.5	
	0.106	381	1.68	4.6	
	0.106	383	1.69		3.0
	0.108	389	1.71	4.7	
	0.110	394	1.74		3.1
	0.110	396	1.75	4.8	
	0.112	404	1.78	4.9	
	0.113	406	1.79		3.2
	0.114	412	1.81	5.0	
	0.116	417	1.84		3.3
	0.119	428	1.89		3.4
	0.122	440	1.94		3.5
	0.125	451	1.98		3.6
	0.128	462	2.03		3.7
	0.132	473	2.08		3.8
	0.135	485	2.13		3.9
	0.138	496	2.18		4.0
	0.141	507	2.23		4.1
	0.144	519	2.28		4.2
	0.147	530	2.33		4.3
	0.150	541	2.38		4.4
	0.153	553	2.43		4.5
	0.157	564	2.48		4.6
	0.160	575	2.53		4.7
	0.163	586	2.58		4.8
	0.166	598	2.63		4.9
	0.169	609	2.68		5.0

Accuracy: Greatest of either ±5% of controlled flow rate or ±2% of maximum flow rate

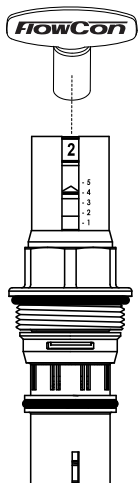

Use the FlowCon adjustment key (part number ACC0001) for adjusting the flow rate.

A setting of 4.2 corresponds to a flow rate of 0.144 l/sec for the 20mm green insert, range 17-210 kPaD.

## FLOW RATE SETTING - E-JUST INSERT - FOR VALVES DN15-DN25 SMALL (continued)

20mm · 3/4" · E-JUST · Y-type · White pawl				
Pressure range. ΔP: 17-200 kPaD · 2.5-29 psid				
	Model no.			E-JUST1.Y.R
	l/sec	l/hr	GPM	Red
				Setting
Nominal flow rate	0.0767	276	1.22	1.0
	0.0813	293	1.29	1.1
	0.0860	310	1.36	1.2
	0.0907	326	1.44	1.3
	0.0953	343	1.51	1.4
	0.100	360	1.58	1.5
	0.105	377	1.66	1.6
	0.109	393	1.73	1.7
	0.114	410	1.80	1.8
	0.118	426	1.88	1.9
	0.123	443	1.95	2.0
	0.128	459	2.02	2.1
	0.132	475	2.09	2.2
	0.136	491	2.16	2.3
	0.141	507	2.23	2.4
	0.145	523	2.30	2.5
	0.150	539	2.37	2.6
	0.154	554	2.44	2.7
	0.158	569	2.51	2.8
	0.162	584	2.57	2.9
	0.166	599	2.64	3.0
	0.170	614	2.70	3.1
	0.174	628	2.76	3.2
	0.178	642	2.83	3.3
	0.182	655	2.89	3.4
	0.186	669	2.94	3.5
	0.189	682	3.00	3.6
	0.193	695	3.06	3.7
	0.196	707	3.11	3.8
	0.200	719	3.17	3.9
0.203	731	3.22	4.0	
0.206	742	3.27	4.1	
0.209	753	3.32	4.2	
0.212	764	3.36	4.3	
0.215	774	3.41	4.4	
0.218	784	3.45	4.5	
0.220	793	3.49	4.6	
0.223	802	3.53	4.7	
0.225	810	3.57	4.8	
0.227	818	3.60	4.9	
0.229	825	3.60	5.0	

Accuracy: Greatest of either ±5% of controlled flow rate or ±2% of maximum flow rate

20mm · 3/4" · E-JUST · G-type · Grey pawl				
Pressure range. ΔP: 30-400 kPaD · 4.4-58 psid				
	Model no.			E-JUST1.G.R
	l/sec	l/hr	GPM	Red
				Setting
Nominal flow rate	0.113	406	1.79	1.0
	0.119	427	1.88	1.1
	0.125	449	1.98	1.2
	0.131	470	2.07	1.3
	0.137	492	2.17	1.4
	0.143	513	2.26	1.5
	0.149	535	2.36	1.6
	0.155	556	2.45	1.7
	0.161	578	2.54	1.8
	0.167	599	2.64	1.9
	0.172	621	2.73	2.0
	0.178	642	2.83	2.1
	0.184	664	2.92	2.2
	0.190	685	3.02	2.3
	0.196	707	3.11	2.4
	0.202	728	3.21	2.5
	0.208	750	3.30	2.6
	0.214	771	3.40	2.7
	0.220	793	3.49	2.8
	0.226	814	3.59	2.9
	0.232	836	3.68	3.0
	0.238	857	3.78	3.1
	0.244	879	3.87	3.2
	0.250	900	3.96	3.3
	0.256	922	4.06	3.4
	0.262	943	4.15	3.5
	0.268	965	4.25	3.6
	0.274	987	4.34	3.7
	0.280	1010	4.44	3.8
	0.286	1030	4.53	3.9
0.292	1050	4.63	4.0	
0.298	1070	4.72	4.1	
0.304	1090	4.82	4.2	
0.310	1120	4.91	4.3	
0.316	1140	5.01	4.4	
0.322	1160	5.10	4.5	
0.328	1180	5.20	4.6	
0.334	1200	5.29	4.7	
0.340	1220	5.38	4.8	
0.346	1240	5.48	4.9	
0.352	1270	5.57	5.0	

Accuracy: Greatest of either ±5% of controlled flow rate or ±2% of maximum flow rate

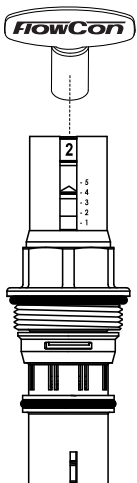
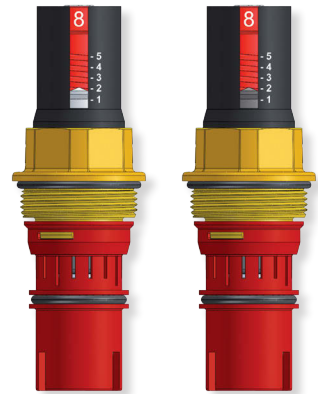

Use the FlowCon adjustment key (part number ACC0001) for adjusting the flow rate.

A setting of 4.2 corresponds to a flow rate of 0.304 l/sec for the 20mm red insert, range 30-400 kPaD.

**FLOW RATE SETTING - E-JUST INSERT - FOR VALVES DN15-DN25 SMALL (continued)**

20mm · 3/4" · E-JUST · G-type · Grey pawl					
Pressure range, ΔP: 35-400 kPaD · 5.1-58 psid					
Nominal flow rate	Model no.		E-JUST1.G.B	E-JUST1.G.G	
	l/sec	l/hr	GPM	Black	Green
				Setting	Setting
	0.0383	138	0.607	1.0	
	0.0416	150	0.660	1.1	
	0.0449	162	0.712	1.2	
	0.0483	174	0.765	1.3	
	0.0516	186	0.817	1.4	
	0.0549	198	0.870	1.5	
	0.0582	210	0.922	1.6	
	0.0615	221	0.975	1.7	
	0.0648	233	1.03	1.8	
	0.0660	238	1.05		1.0
	0.0681	245	1.08	1.9	
	0.0706	254	1.12		1.1
	0.0714	257	1.13	2.0	
	0.0748	269	1.18	2.1	
	0.0751	271	1.19		1.2
	0.0781	281	1.24	2.2	
	0.0797	287	1.26		1.3
	0.0814	293	1.29	2.3	
	0.0843	304	1.34		1.4
	0.0847	305	1.34	2.4	
	0.0880	317	1.40	2.5	
	0.0889	320	1.41		1.5
	0.0913	329	1.45	2.6	
	0.0934	336	1.48		1.6
	0.0946	341	1.50	2.7	
	0.0979	353	1.55	2.8	
	0.0980	353	1.55		1.7
	0.101	365	1.61	2.9	
	0.103	369	1.63		1.8
	0.105	377	1.66	3.0	
	0.107	386	1.70		1.9
	0.108	388	1.71	3.1	
	0.111	400	1.76	3.2	
	0.112	402	1.77		2.0
	0.115	412	1.82	3.3	
	0.116	419	1.84		2.1
	0.118	424	1.87	3.4	
	0.121	435	1.92		2.2
	0.121	436	1.92	3.5	
	0.124	448	1.97	3.6	
	0.125	452	1.99		2.3
	0.128	460	2.03	3.7	
	0.130	468	2.06		2.4
	0.131	472	2.08	3.8	

Continue next column...

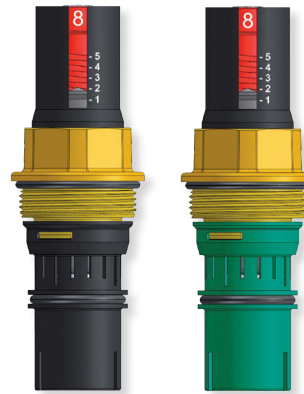

20mm · 3/4" · E-JUST · G-type · Grey pawl					
Pressure range, ΔP: 35-400 kPaD · 5.1-58 psid					
Nominal flow rate	Model no.		E-JUST1.G.B	E-JUST1.G.G	
	l/sec	l/hr	GPM	Black	Green
				Setting	Setting
	0.134	484	2.13	3.9	
	0.135	485	2.13		2.5
	0.138	496	2.18	4.0	
	0.139	501	2.21		2.6
	0.141	508	2.24	4.1	
	0.144	517	2.28		2.7
	0.144	520	2.29	4.2	
	0.148	532	2.34	4.3	
	0.148	534	2.35		2.8
	0.151	544	2.39	4.4	
	0.153	550	2.42		2.9
	0.154	556	2.45	4.5	
	0.157	567	2.50		3.0
	0.158	567	2.50	4.6	
	0.161	579	2.55	4.7	
	0.162	583	2.57		3.1
	0.164	591	2.60	4.8	
	0.167	600	2.64		3.2
	0.168	603	2.66	4.9	
	0.171	615	2.71	5.0	
	0.171	616	2.71		3.3
	0.176	633	2.79		3.4
	0.180	649	2.86		3.5
	0.185	666	2.93		3.6
	0.189	682	3.00		3.7
	0.194	699	3.08		3.8
	0.199	715	3.15		3.9
	0.203	731	3.22		4.0
	0.208	748	3.29		4.1
	0.212	764	3.37		4.2
	0.217	781	3.44		4.3
	0.221	797	3.51		4.4
	0.226	814	3.58		4.5
	0.231	830	3.66		4.6
	0.235	847	3.73		4.7
	0.240	863	3.80		4.8
	0.244	880	3.87		4.9
	0.249	896	3.95		5.0

Accuracy: Greatest of either ±5% of controlled flow rate or ±2% of maximum flow rate

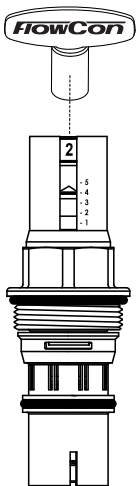

Use the FlowCon adjustment key (part number ACC0001) for adjusting the flow rate.

A setting of 4.2 corresponds to a flow rate of 0.212 l/sec for the 20mm green insert, range 35-400 kPaD.

## FLOW RATE SETTING - E-JUST INSERT - FOR VALVES DN25 LARGE-DN40

40mm · 1 1/2" · E-JUST · Y-type · White pawl					
Pressure range. ΔP: 17-400 kPaD · 2.5-58 psid					
		Model no.	E-JUST2.Y.G		
Nominal flow rate		l/sec	l/hr	GPM	Setting
		0.149	535	2.36	1.0
		0.220	793	3.49	1.1
		0.289	1040	4.58	1.2
		0.355	1280	5.63	1.3
		0.418	1510	6.63	1.4
		0.479	1730	7.60	1.5
		0.538	1940	8.52	1.6
		0.594	2140	9.41	1.7
		0.647	2330	10.3	1.8
		0.699	2520	11.1	1.9
		0.748	2690	11.9	2.0
		0.795	2860	12.6	2.1
		0.841	3030	13.3	2.2
		0.884	3180	14.0	2.3
		0.925	3330	14.7	2.4
		0.965	3470	15.3	2.5
		1.00	3610	15.9	2.6
		1.04	3740	16.5	2.7
		1.07	3870	17.0	2.8
	1.11	3990	17.6	2.9	
	1.14	4100	18.1	3.0	
	1.17	4220	18.6	3.1	
	1.20	4320	19.0	3.2	
	1.23	4420	19.5	3.3	
	1.26	4520	19.9	3.4	
	1.28	4620	20.3	3.5	
	1.31	4710	20.7	3.6	
	1.33	4800	21.1	3.7	
	1.36	4890	21.5	3.8	
	1.38	4970	21.9	3.9	
	1.40	5050	22.3	4.0	
	1.43	5130	22.6	4.1	
	1.45	5210	23.0	4.2	
	1.47	5290	23.3	4.3	
	1.49	5370	23.6	4.4	
	1.51	5440	24.0	4.5	
	1.53	5520	24.3	4.6	
	1.55	5600	24.6	4.7	
	1.58	5670	25.0	4.8	
	1.60	5750	25.3	4.9	
	1.62	5830	25.7	5.0	

Accuracy: Greatest of either ±5% of controlled flow rate or ±2% of maximum flow rate

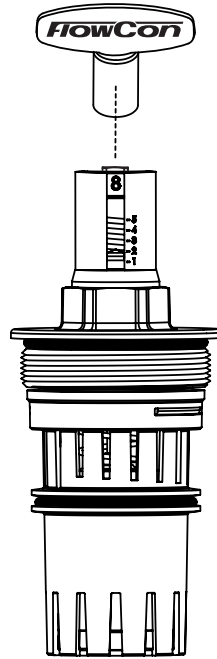
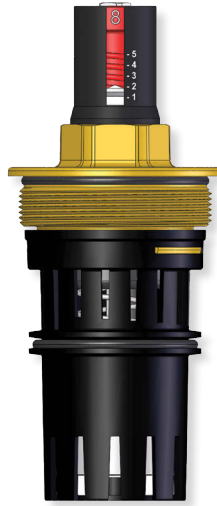

Use the FlowCon adjustment key (part number ACC0001) for adjusting the flow rate.

A setting of 4.2 corresponds to a flow rate of 1.45 l/sec for the 40mm insert, range 17-400 kPaD.

## ACTUATOR SPECIFICATIONS<sup>6</sup>

Supply voltage:	24V: 22-26V AC / 28-32V DC 240V: 220-250V AC 50/60Hz Modulating: 22-26V AC / 28-32V DC
Control signal:	2-position / 3-point-floating or modulating 2-10V DC / 4-20mA
Max. power consumption:	24V: 6VA 240V: 7 watts at 240V AC Modulating: 6VA
Electrical connection:	18 AWG (0.8mm <sup>2</sup> ) minimum
Angle of rotation:	0°-90°, mechanically adjustable
Torque at rated voltage:	5.6 Nm
Direction of rotation:	Reversible
Rotation time through 90°:	24V: 90-110 sec 240V: 20-30 sec, torque dependent Modulating: 90-110 sec
Auxiliary switches:	2 mechanical, fixed at 10° and 80° (only on types 4, 5 and 6)
Auxiliary switch rating:	1 Amp resistive, 24V AC
Housing material:	Electronic enclosure: flammability rating UL94-5V
Gear train enclosure:	Die cast zinc with a steel base
Ambient temperature:	-20°C to +50°C
Humidity rating:	5 to 95% non condensing
Protection:	IP22, NEMA type 2
Weight:	1.4 kg
Cable:	Actuators do not include length of cable. Actuators can be field wired up to 45 mtr.

Note 6: FlowCon warranty is voided using other actuators than supplied or recommended by FlowCon International.

## ACTUATOR DESCRIPTION

The three standard actuators available for the FlowCon ABM valve are basic digital actuators that operate on 24V AC and 240V AC or a modulating version operating on 24V AC respectively. All models deliver a minimum of 5.6 Nm torque at rated voltage. The direction of rotation is reversible and the angle of rotation may be mechanically limited. Actuators are available with 2 mechanical auxiliary switches.

Note: Do not press clutch on actuator, when actuator is powered.

# WIRING SCHEMATICS

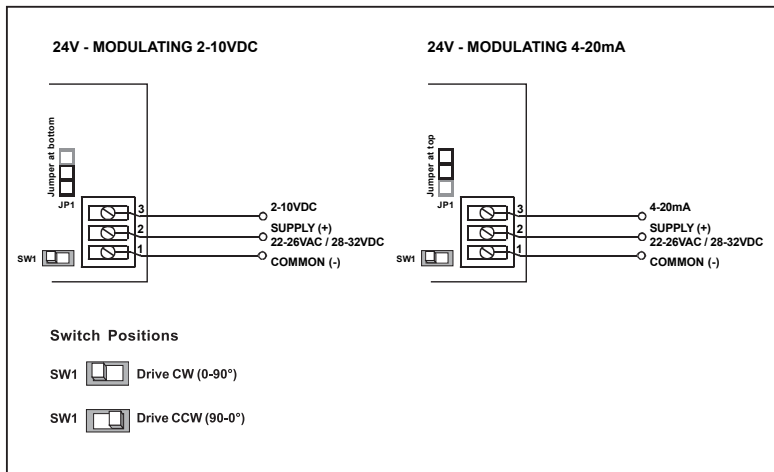
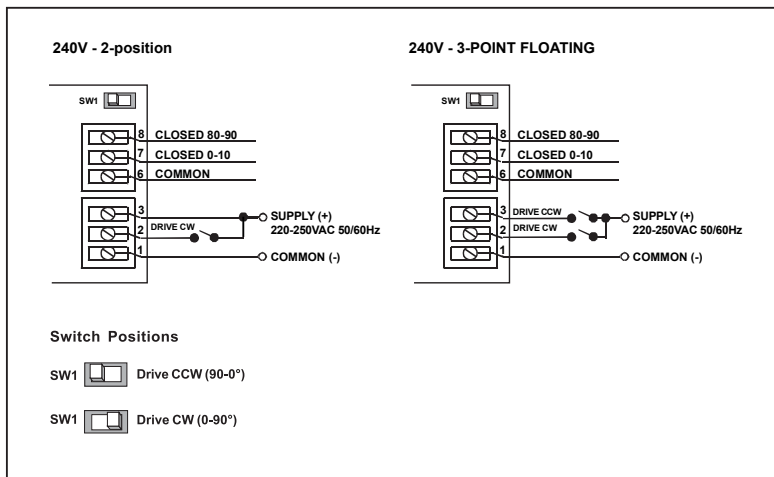
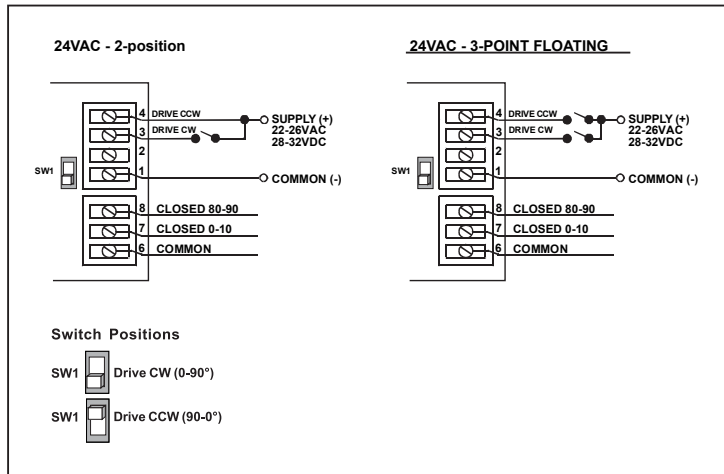

## ACCESSORIES

- P/t plugs: 2 x ACC00101
- Blind cap: ACC0080 / ACC0081 (cap (small / medium) without an insert for flushing out the system)
- Adjustment key: ACC0001 (key for adjusting the flow rate on E-JUST inserts and turning the ball valve).

## GENERAL SPECIFICATIONS

### 1. AUTOMATIC BALANCING AND TEMPERATURE CONTROL VALVES - FLOWCON ABM

- 1.1. Contractor shall install balancing / temperature control valves where indicated in drawings.
- 1.2. Valve shall consist of dynamic, accessible, adjustable flow limiting device and integral electrically actuated two-way control valve.

### 2. VALVE ACTUATOR

- 2.1. Actuator housing shall be rated to IP22.
- 2.2. Actuator shall be driven by a 22-26V AC / 28-32V DC or 220-250V AC 50/60Hz motor and shall accept 2-10V DC, 4-20mA, 3-point-floating or 2-position electric signal depending on actuator selection.
- 2.3. Actuator shall have a power consumption not exceeding 6VA at 24V AC or 7 watts at 240V AC depending on actuator selection.
- 2.4. Actuator shall provide minimum torque required for full valve shut off position.

### 3. VALVE HOUSING AND ACTUATED BALL VALVE

- 3.1. Valve housing shall consist of forged brass ASTM CuZn40Pb2, rated at no less than 2500 kPa at +120°C.
- 3.2. Valve ball shall consist of chemically nickel plated brass (CuZn40Pb2). A range of inserts made of glass filled polymer providing equal percentage control shall be available from the manufacturer.
- 3.3. Each valve size shall be available with the choice of 4 unique Kvs values for the ball valve.
- 3.4. Valve housing shall be permanently marked to show direction of flow.
- 3.5. Valve housing shall be double union end constructed with a range of pipe connections available for the appropriate pipe size.
- 3.6. Optional dual pressure/temperature test plugs for verifying accuracy of flow performance shall be available for all valve sizes.
- 3.7. Housing shall be configured for flow regulation unit accessibility.

### 4.a. FLOW REGULATOR / AUTOMATIC BALANCING UNIT / COMPOSITE INSERT

- 4.a.1. Flow regulation unit assembly shall be manufactured of polyoxymethylene with a hydrogenated acrylonitrile-butadiene rubber or EPDM diaphragm and stainless steel 18-8 spring.
- 4.a.2. Flow regulation unit shall be readily accessible for change-out or maintenance.
- 4.a.3. Flow regulation unit shall be adjustable to 1 of 8 different flow rates; shall be available in 2 different kPaD operational ranges for DN15/20/25 and 3 different kPaD operational ranges for DN25/32/40; minimum range shall be capable of being activated by minimum 15 kPaD. Further, the flow regulation unit shall be capable of controlling flow within  $\pm 10\%$  of rated flow rate or 20l/hr.
- 4.a.4. Identification tags shall be available for all valves; tags shall be indelibly marked with flow rate, color and dial setting.

OR....

### 4.b. FLOW REGULATOR / AUTOMATIC BALANCING UNIT / E-JUST INSERT

- 4.b.1. Flow regulation unit assembly shall be manufactured of polysulfone with a hydrogenated acrylonitrile-butadiene rubber or EPDM diaphragm and stainless steel 18-8 spring.
- 4.b.2. Flow regulation unit shall be readily accessible for change-out or maintenance.
- 4.b.3. Flow regulation unit shall be adjustable with the valve in-line and the system in operation.
- 4.b.4. Flow regulation unit shall be externally adjustable to 1 of 41 different flow rates; shall be available in 4 different kPaD operational ranges for DN15/20/25 and 1 kPaD operational range for DN25/32/40; minimum range shall be capable of being activated by minimum 17 kPaD. Further, the flow regulation unit shall be capable of controlling flow within  $\pm 5\%$  of rated flow or  $\pm 2\%$  of maximum flow.
- 4.b.5. Identification tags shall be available for all valves; tags shall be indelibly marked with flow rate, color and dial setting.

## APPLICATION AND SCHEMATIC EXAMPLE

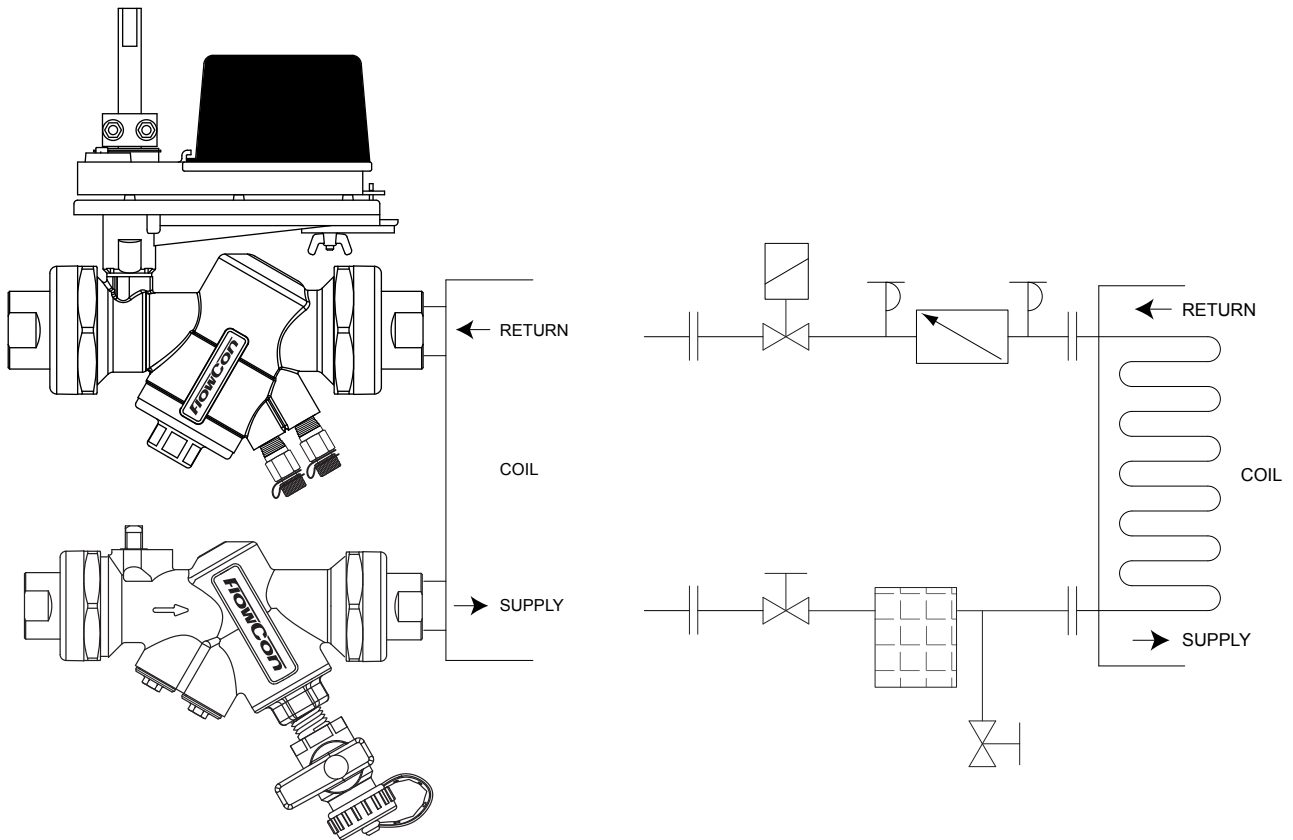

## UPDATES

For latest updates please see [www.flowcon.com](http://www.flowcon.com)

FlowCon International can accept no responsibility for possible errors in any printed material. All rights reserved.

# FlowCon Unimizer 2-way 15-80mm

## Actuated Control Valves



### SPECIFICATIONS

Pressure rating:	2400 kPa / 360 psi
Temperature rating, media:	-20°C to +120°C / -4°F to +248°F
Temperature rating, ambient:	-20°C to +50°C / -4°F to +122°F
Media:	Chilled water, hot water (Fluid grp. 2) For higher glycol content than 50% or additional fluids, please consult factory
Material:	
- Flow Optimizer:	Glass filled polymer
- Body:	Forged brass DZR CW602
- End connections <sup>1</sup> :	Brass - ISO or NPT <sup>1</sup>
- Field repairable stem:	Dual teflon seals and EPDM o-ring
- Stem seals:	EPDM o-rings
- Ball valve:	Nickel-plated brass ball Optional: Stainless steel ball
- Ball seals:	Teflon seals with EPDM o-rings
Angel of rotation:	0-90°
Leakage rates:	IEC 60534-1 Class IV

Note 1: NPT only available ex. US-factory.

## DIMENSIONS AND WEIGHTS (NOMINAL) (measured in mm unless noted)

Model no.	Size (mm)	Size (")	Kv (m <sup>3</sup> /h)	L1	L2	H1	H2	D depth (not shown)	E (handle)	Weight <sup>2</sup> (kgs)
				ISO/NPT	ISO/NPT					
FUR2.A_	15	1/2	0.33 0.59 1.12 2.24 4.05 6.90 10.09	60.2	168.9	96.0	211.3	76.2	51.3	0.5
FUR2.B_	20	3/4	0.27 0.54 1.03 2.16 3.71 12.67	61.2	168.9	96.0	218.9	76.2	51.3	0.5
			8.71 24.66	70.1	168.9	102.9				
FUR2.C_	25	1	7.76 24.48	70.1	168.9	104.1	219.5	76.2	51.3	0.5
			3.79 13.19 22.50 37.84 46.72	77.2	170.9	111.5	227.6			0.7
FUR2.D_	32	1 1/4	3.79 7.16 12.84 35.43	76.5	170.4	114.1	229.1	76.2	51.3	0.7
			31.47 88.19	92.0	179.1	123.7	240.0			1.2
FUR2.E_	40	1 1/2	19.66 63.71	87.1	176.8	123.7	240.0	76.2	51.3	1.2
			35.60 148.02	103.1	184.7	138.2	254.5			1.5
FUR2.F_	50	2	35.95 93.10	101.1	183.1	138.2	254.5	88.9	51.3	1.5
			49.14 61.29 86.21 181.03 220.69	124.5	195.3	153.9	270.5			2.3
FUR2.G_	65	2 1/2	38.79 47.41 62.33 87.07 139.66 174.14	135.9	200.9	153.9	270.5	88.9	51.3	2.5
FUR2.H_	80	3	42.24 54.31 70.69 106.90 125.00	145.5	205.7	162.1	277.1	101.6	51.3	2.9

Note 2: The weight is without actuator.

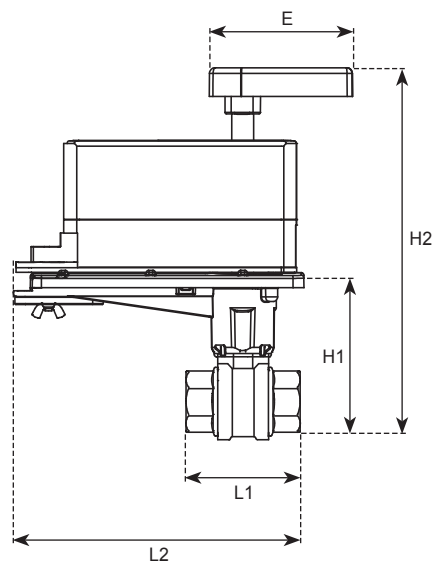

## MODEL NUMBER SELECTION

**FUR2** .

Insert ball size:

**A**=15mm, 1/2"   **B**=20mm, 3/4"   **C**=25mm, 1"   **D**=32mm, 1 1/4"  
**E**=40mm, 1 1/2"   **F**=50mm, 2"   **G**=65mm, 2 1/2"   **H**=80mm, 3"

Insert a Kv value (**1, 2, 3, 4, 5, 6, 7** or **8**) (see flow rate table next page):

Select connection standard:

**I**=ISO   **N**=NPT (NPT only available ex. US-factory)

Select ball and stem:

**B**=Standard   **S**=Optional 316 SS   **C**=Standard ball with SS stem

Insert mounting kit number:

**1**=FlowCon  
**2**=Johnson Controls  
**3**=Invensys  
**4**=Honeywell  
**5**=Siemens  
**6**=Belimo  
**7**=KMC Controls

Insert power supply, actuator:

**0**=if no actuator required  
**10**=24V 2-position or 3-point floating (without end switches) (BBTS1000)  
**20**=240V 2-position or 3-point floating (without end switches) (BBTHV1200A)  
**30**=24V modulating (without end switches) (BBMS2000)  
**40**=24V 2-position or 3-point floating incl. auxiliary switches (BBTS1021)  
**50**=240V 2-position or 3-point floating incl. auxiliary switches (BBTHV1221A)  
**60**=24V modulating incl. auxiliary switches (BBMS2021)

**T**=Optional aluminum hanging ID tag

Example: FUR2.A.3.I.B.1.10.T=Unimixer 2-way 15mm (Kv equal to 1.12 m<sup>3</sup>/h) with ISO end connections, standard ball and stem, FlowCon mounting kit, 24V 2-position actuator and ID-tag.

## Kv SELECTION AND FLOW RATE TABLE (l/h)

Line size (mm)	Model no	Full <sup>3</sup> port	Close OFF $\Delta P^4$ (bar)	Flow rate (l/h) differential pressure (kPa) across valve												Kv <sup>5</sup> (m <sup>3</sup> /h)	Through Kv
				5	10	15	20	25	30	40	50	60	70	80	90		
15	FUR2.A.1_		9	72	101	124	143	160	175	202	226	248	268	286	304	0.32	1
	FUR2.A.2_			132	187	229	264	295	323	373	417	457	494	528	560	0.59	2
	FUR2.A.3_			250	354	434	501	560	613	708	792	868	937	1002	1063	1.12	3
	FUR2.A.4_			501	708	868	1002	1120	1227	1417	1584	1735	1874	2004	2125	2.24	4
	FUR2.A.5_			906	1281	1569	1811	2025	2218	2561	2864	3137	3388	3622	3842	4.05	5
	FUR2.A.6_	•		2254	3188	3904	4508	5040	5521	6375	7128	7808	8434	9016	9563	10.08	6
	FUR2.A.7_			1543	2182	2672	3086	3450	3779	4364	4879	5345	5773	6172	6546	6.90	7
20	FUR2.B.6_		9	60	85	105	121	135	148	171	191	209	226	241	256	0.27	6
	FUR2.B.7_			121	171	209	241	270	296	342	382	418	452	483	512	0.54	7
	FUR2.B.8_			230	326	399	461	515	564	651	728	798	862	921	977	1.03	8
	FUR2.B.1_			483	683	837	966	1080	1183	1366	1527	1673	1807	1932	2049	2.16	1
	FUR2.B.2_			827	1170	1433	1655	1850	2027	2340	2616	2866	3096	3309	3510	3.70	2
	FUR2.B.3_	•		2833	4007	4907	5666	6335	6940	8013	8959	9814	10600	11332	12020	12.67	3
	FUR2.B.4_			1948	2754	3373	3895	4355	4771	5509	6159	6747	7287	7790	8263	8.71	4
FUR2.B.5_	•	5514	7798	9551	11028	12330	13507	15596	17437	19102	20632	22057	23395	24.66	5		
25	FUR2.C.1_		7	1735	2454	3005	3470	3880	4250	4908	5487	6011	6492	6941	7362	7.76	1
	FUR2.C.2_	•		5474	7741	9481	10948	12240	13408	15483	17310	18962	20481	21896	23224	24.48	2
	FUR2.C.7_			847	1199	1468	1695	1895	2076	2397	2680	2936	3171	3390	3596	3.79	7
	FUR2.C.3_			2949	4171	5108	5899	6595	7224	8342	9327	10217	11036	11797	12513	13.19	3
	FUR2.C.4_	•		10447	14774	18095	20894	23360	25590	29548	33036	36189	39089	41788	44322	46.72	4
	FUR2.C.5_			5031	7115	8714	10062	11250	12324	14230	15910	17428	18825	20125	21345	22.50	5
	FUR2.C.6_			8461	11966	14655	16923	18920	20726	23932	26757	29311	31659	33845	35898	37.84	6
32	FUR2.D.5_		7	847	1199	1468	1695	1895	2076	2397	2680	2936	3171	3390	3596	3.79	5
	FUR2.D.6_			1601	2264	2773	3202	3580	3922	4528	5063	5546	5990	6404	6793	7.16	6
	FUR2.D.1_			2871	4060	4973	5742	6420	7033	8121	9079	9946	10743	11484	12181	12.84	1
	FUR2.D.2_	•		7922	11204	13722	15845	17715	19406	22408	25053	27444	29643	31690	33612	35.43	2
	FUR2.D.3_			7035	9949	12184	14069	15730	17231	19897	22246	24369	26321	28139	29846	31.46	3
	FUR2.D.4_	•		19720	27888	34156	39440	44095	48304	55776	62360	68312	73785	78880	83664	88.19	4
40	FUR2.E.1_		7	4396	6217	7614	8792	9830	10768	12434	13902	15229	16449	17584	18651	19.66	1
	FUR2.E.2_	•		14244	20144	24671	28488	31850	34890	40287	45043	49342	53295	56975	60431	63.70	2
	FUR2.E.3_			7960	11258	13788	15921	17800	19499	22515	25173	27576	29785	31842	33773	35.60	3
	FUR2.E.4_	•		33094	46802	57320	66188	74000	81063	93603	104652	114640	123826	132375	140405	148.00	4
50	FUR2.F.1_		7	8039	11368	13923	16077	17975	19691	22737	25420	27847	30078	32155	34105	35.95	1
	FUR2.F.2_	•		20818	29441	36057	41636	46550	50993	58882	65832	72115	77893	83271	88322	93.10	2
	FUR2.F.5_			10988	15539	19032	21976	24570	26915	31079	34747	38064	41113	43952	46618	49.14	5
	FUR2.F.3_			13705	19382	23738	27410	30645	33570	38763	43339	47475	51279	54819	58145	61.29	3
	FUR2.F.6_			19275	27259	33385	38550	43100	47214	54518	60953	66770	72120	77100	81777	86.20	6
	FUR2.F.7_			40473	57237	70101	80946	90500	99138	114474	127986	140202	151435	161891	171712	181.00	7
	FUR2.F.4_	•		51273	72511	88808	102546	114650	125593	145022	162140	177615	191846	205092	217533	229.30	4
65	FUR2.G.2_		7	8676	12270	15027	17352	19400	21252	24539	27436	30054	32462	34704	36809	38.80	2
	FUR2.G.3_			10601	14992	18362	21202	23705	25968	29985	33524	36724	39666	42405	44977	47.41	3
	FUR2.G.4_			13864	19606	24012	27727	31000	33959	39212	43841	48025	51873	55454	58818	62.00	4
	FUR2.G.5_			19454	27512	33695	38908	43500	47652	55024	61518	67390	72789	77815	82535	87.00	5
	FUR2.G.6_			31229	44164	54090	62458	69830	76495	88329	98755	108180	116848	124916	132493	139.66	6
	FUR2.G.7_	•		38930	55055	67429	77860	87050	95358	110111	123107	134857	145663	155720	165166	174.10	7
80	FUR2.H.1_		7	9445	13357	16359	18890	21120	23136	26715	29868	32719	35341	37781	40072	42.24	1
	FUR2.H.2_			12142	17171	21030	24284	27150	29741	34342	38396	42061	45431	48567	51514	54.30	2
	FUR2.H.3_			15807	22354	27378	31614	35345	38719	44708	49985	54756	59143	63227	67062	70.69	3
	FUR2.H.4_			23904	33805	41402	47807	53450	58552	67609	75590	82804	89439	95614	101414	106.90	4
	FUR2.H.5_	•		27951	39528	48412	55902	62500	68465	79057	88388	96825	104583	111803	118585	125.00	5

Note 3: These valves are full port and do not have the Optimizer insert.

Note 4: Close OFF pressures measured with 4 Nm actuator. The "Close OFF pressure" is the maximum allowable pressure drop across the valve body when the valve is fully closed. (Do not use actuators with torques higher than 10 Nm).

Note 5: Kv is defined as the quantity of water in m<sup>3</sup>/h at 15°C that will flow through a given valve with a pressure drop of 1 bar. Hence the 1.0 bar pressure differential column in the table above is equivalent to the Kv value.

## GENERAL SPECIFICATIONS

### 1. ACTUATED BALL VALVE

- 1.1. Valve housing shall consist of forged brass DZR CW602 rated at no less than 2400 kPa at 120°C.
- 1.2. Manufacturer shall be able to provide glass-filled polymer ball insert to make flow control equal percentage.
- 1.3. Valve ball shall consist of chemically nickel-plated brass. Manufacturer shall be able to provide optional 316 SS ball and stem.
- 1.4. Valve shall have EPDM O-Rings behind ball seals to allow for a minimum close-off pressure of 690 kPa with 4 Nm of torque for 15mm-50mm sizes.
- 1.5. Valve shall be available with a minimum of 25 unique Kv values.
- 1.6. Stem shall be removable/replaceable without removing valve from line and shall include both teflon seals and EPDM O-ring.

### 2. VALVE ACTUATOR

- 2.1. Control valve actuator shall be analog modulating (4-20 mA or 2-10 V), floating (tri-state), pulse width modulation, or two position as indicated in the control sequence.
- 2.2. Actuator shall provide minimum torque required for full valve shutoff position.
- 2.3. A 0.9 m cable shall be provided for installation to electrical junction box.
- 2.4. A universal mounting plate shall allow installation of actuators meeting the system electrical requirements and valve torque requirements as provided by FlowCon, Belimo, ELO Drive, Honeywell, Invensys, Johnson Controls, KMC, Neponics or Siemens. The control valve actuator may be furnished by the controls contractor under Section 15970 or by the valve manufacturer.

### 3. ACCESSORIES

- 3.1. Identification tags shall be available for all valves; tags shall be indelibly marked with Kv, model number and location; tags shall be aluminum.

## UPDATES

**For latest updates please see [www.flowcon.com](http://www.flowcon.com)**

FlowCon International can accept no responsibility for possible errors in any printed material.  
All rights reserved.

# FlowCon Unimizer 2-way 100-150mm

## *Actuated Control Valves*

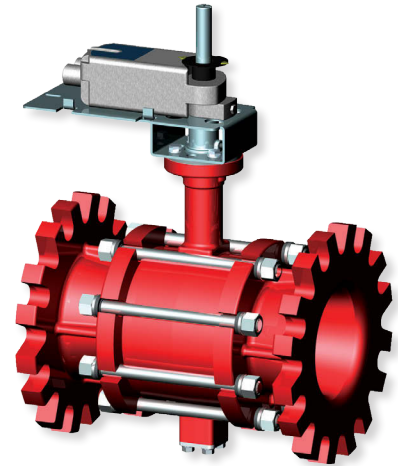

### SPECIFICATIONS

Pressure rating:	1600 kPa / 240 psi
Temperature rating, media:	-20°C to +120°C / -4°F to +248°F
Temperature rating, ambient:	-20°C to +50°C / -4°F to +122°F
Media:	Chilled water, hot water (Fluid grp. 2) For higher glycol content than 50% or additional fluids, please consult factory
Material:	
- Body:	Cast iron ASTM A395, 60-40-18
- End connections:	EN 1092-1 flanges
- Stem:	Stainless steel
- Stem seals:	EPDM o-rings
- Ball valve:	Stainless steel
- Ball seals:	Teflon seals
Angel of rotation:	0-90°
Leakage rate:	IEC 60534-1 Class IV

## DIMENSIONS AND WEIGHTS (NOMINAL) (measured in mm unless noted)

Model no.	Size (mm)	Size (")	Kv (m <sup>3</sup> /h)	L1	L2'	H1	H2	D depth (not shown)	Weight <sup>2</sup> (kgs)
F3UR.J_	100	4	78 102 131 170 219	279.4	337.8	228.6	477.5	228.6	29.5
F3UR.K_	125	5	124 159 207 266 345	315.0	363.2	254.0	482.6	254.0	34.0
F3UR.L_	150	6	179 231 298 380 497 560	353.1	383.5	279.4	505.5	279.4	40.8

Note 1: L2 is maximum length, which is measured from end flange or mounting plate, whichever extends farther.  
 Note 2: The weight is without actuator.

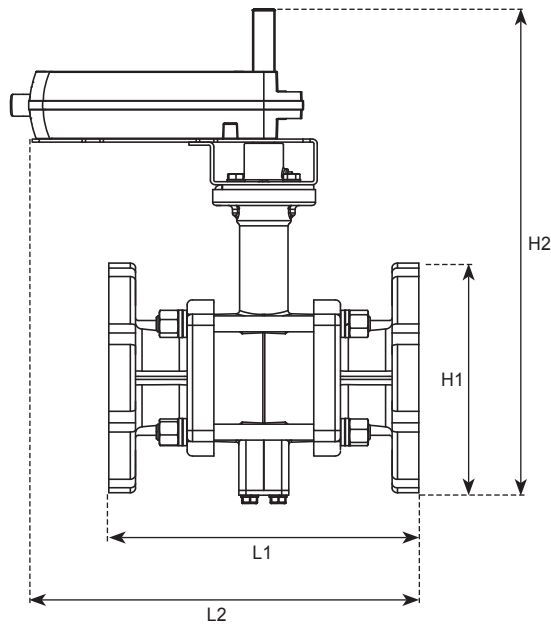

## FLANGE MATCH UNIMIZER

Model no.	Unimizer DN (mm)	EN 1092-1:2007 flanges			
		PN 10	PN 16	PN 25	PN 40
F3UR.J_	100	✓	✓	✓	✓
F3UR.K_	125	✓	✓	✓	✓
F3UR.L_	150	✓	✓	✓	✓

## MODEL NUMBER SELECTION

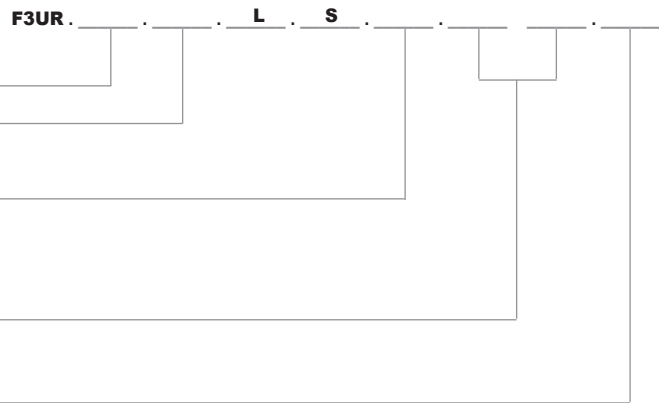

Insert ball size:

**J**=100mm, 4" **K**=125mm, 5" **L**=150mm, 6"

Insert a Kv value (**1, 2, 3, 4, 5** or **6**) (see flow rate table below):

Insert mounting kit number:

**1**=FlowCon  
**4**=Honeywell  
**5**=Siemens

Insert power supply, actuator:

**0**=if no actuator required  
**10**=24V 2-position or 3-point floating (without end switches) (TT000)  
**20**=240V 2-position or 3-point floating (without end switches) (TT300)  
**40**=24V 2-position or 3-point floating incl. auxiliary switches (TT020)  
**50**=240V 2-position or 3-point floating incl. auxiliary switches (TM300)  
**60**=24V modulating incl. auxiliary switches (TM000)

**T**=Optional aluminum hanging ID tag

Example: F3UR.J.3.L.S.1.10.T=Unimizer 2-way 100mm (Kv equal to 131 m<sup>3</sup>/h) with FlowCon mounting kit, 24V 2-position actuator and ID-tag.

## Kv SELECTION AND FLOW RATE TABLE (l/h)

Line size (mm)	Model no	Close OFF $\Delta P^3$ (bar)	Flow rate (l/h) differential pressure (kPa) across valve											Kv <sup>4</sup> m <sup>3</sup> /h	Kv for model no. selection	
			5	10	15	20	25	30	40	50	60	70	80			90
100	F3UR.J.1_	5	17350	24536	30050	34699	38795	42498	49072	54864	60101	64916	69399	73608	78	1
	F3UR.J.2_		22748	32170	39400	45495	50865	55720	64340	71934	78800	85113	90990	96510	102	2
	F3UR.J.3_		29299	41435	50748	58598	65515	71768	82871	92652	101495	109628	117197	124306	131	3
	F3UR.J.4_		37975	53705	65775	75950	84915	93020	107410	120088	131550	142090	151901	161115	170	4
	F3UR.J.5_		48970	69254	84818	97940	109500	119951	138508	154856	169637	183229	195880	207762 <sup>5</sup>	219	5
125	F3UR.K.1_	5	27759	39257	48079	55517	62070	67994	78513	87780	96158	103863	111034	117770	124	1
	F3UR.K.2_		35665	50438	61774	71331	79750	87362	100877	112784	123548	133447	142661	151315	159	2
	F3UR.K.3_		46264	65428	80132	92528	103450	113324	130855	146300	160264	173105	185057	196283	207	3
	F3UR.K.4_		59569	84243	103176	119138	133200	145913	168486	188373	206353 <sup>5</sup>	222886 <sup>5</sup>	238275 <sup>5</sup>	-	266	4
	F3UR.K.5_		77106	109045	133552	154213	172415	188871	218090 <sup>5</sup>	243832 <sup>5</sup>	267104 <sup>5</sup>	288505 <sup>5</sup>	-	-	345	5
150	F3UR.L.1_	5	40093	56700	69443	80185	89650	98207	113399	126784	138885	150013	160371	170099	179	1
	F3UR.L.2_		51653	73049	89466	103306	115500	126524	146097	163342	178932	193268	206613 <sup>5</sup>	219146 <sup>5</sup>	231	2
	F3UR.L.3_		66702	94331	115531	133404	149150	163386	188661	210930 <sup>5</sup>	231062 <sup>5</sup>	249576 <sup>5</sup>	266808 <sup>5</sup>	-	298	3
	F3UR.L.4_		85015	120230	147251	170031	190100	208244 <sup>5</sup>	240460 <sup>5</sup>	268842 <sup>5</sup>	294502 <sup>5</sup>	-	-	-	380	4
	F3UR.L.5_		111222	157292	192642	222444 <sup>5</sup>	248700 <sup>5</sup>	272437 <sup>5</sup>	-	-	-	-	-	-	497	5
	F3UR.L.6_		125287	177182	217003 <sup>5</sup>	250574 <sup>5</sup>	-	-	-	-	-	-	-	-	560	6

Note 3: Close OFF pressures measured with 10 Nm actuator for 100-125mm valves. Close OFF pressures measured with 15 Nm actuator for 150mm valve, up to 159000 l/h. For flowrates greater than 159000 l/h a 22 Nm actuator is recommended.

The "Close OFF pressure" is the maximum allowable pressure drop across the valve body when the valve is fully closed.

Note 4: Kv is defined as the quantity of water in m<sup>3</sup>/h at 15°C that will flow through a given valve with a pressure drop of 1 bar.

Hence the 1.0 bar pressure differential column in the table above is equivalent to the Kv value.

Note 5: Due to high velocity, flowrates of 204500 l/h and higher may result in water noise.

## GENERAL SPECIFICATIONS

### 1. ACTUATED BALL VALVE

- 1.1. Valve housing shall consist of cast iron ASTM A395, 60-40-18 rated at no less than 1600 kPa at 120°C. Valve housing shall have EN 1092-1 flanges.
- 1.2. Valve ball shall consist of stainless steel with parabolic ports to make flow control equal percentage.
- 1.3. Valve shall have a blow-out proof stem with two EPDM O-Rings.
- 1.4. Valve shall have EPDM O-Rings behind ball seals to allow for a minimum close-off pressure of 480 kPa with 10 Nm of torque for 100mm and 125 mm valves. 150mm valves shall require actuators with 15 Nm of torque for flowrates under 159000 l/h.
- 1.5. Valve shall be available with a minimum of 5 unique Kv values for each size.

### 2. VALVE ACTUATOR

- 2.1. Control valve actuator shall be analog modulating (4-20 mA or 2-10 V), floating (tri-state), pulse width modulation, or two position as indicated in the control sequence.
- 2.2. Actuator shall provide minimum torque required for full valve shutoff position.
- 2.3. A 0.9 m cable shall be provided for installation to electrical junction box.
- 2.4. A universal mounting plate shall allow installation of actuators meeting the system electrical requirements and valve torque requirements as provided by FlowCon, Honeywell, Neponics, or Siemens. The control valve actuator may be furnished by the controls contractor under Section 15970 or by the valve manufacturer.

### 3. ACCESSORIES

- 3.1. Identification tags shall be available for all valves; tags shall be indelibly marked with Kv, model number and location; tags shall be aluminum.

## UPDATES

**For latest updates please see [www.flowcon.com](http://www.flowcon.com)**

FlowCon International can accept no responsibility for possible errors in any printed material.  
All rights reserved.

# FlowCon Unimizer 3-way 15-80mm

## Actuated Control Valves

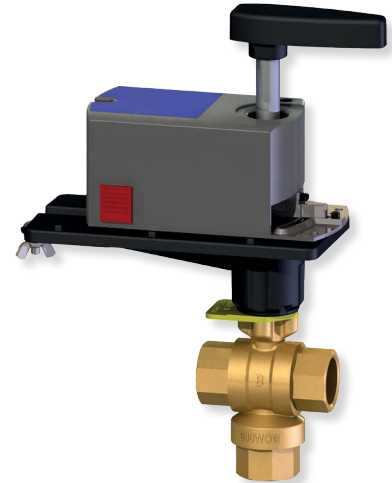

### SPECIFICATIONS

Pressure rating:	2400 kPa / 360 psi
Temperature rating, media:	-20°C to +120°C / -4°F to +248°F
Temperature rating, ambient:	-20°C to +50°C / -4°F to +122°F
Media:	Chilled water, hot water (Fluid grp. 2) For higher glycol content than 50% or additional fluids, please consult factory
Material:	
- Flow Optimizer:	Glass filled polymer
- Body:	Forged brass DZR CW602
- End connections <sup>1</sup> :	Brass - ISO or NPT <sup>1</sup>
- Field repairable stem:	Dual teflon seals and EPDM o-ring
- Stem seals:	EPDM o-rings
- Ball valve:	Nickel-plated brass ball
- Ball seals:	Teflon seals with EPDM o-rings
Angle of rotation:	0-90°
Installation:	Valve can be installed in mixing or diverting installations.
Leakage rates:	IEC 60534-1 Class IV

Note1: NPT only available ex. US-factory

## DIMENSIONS AND WEIGHTS (NOMINAL) (measured in mm unless noted)

Model no.	Size (mm)	Size (")	Kv (m <sup>3</sup> /h)	L1	L2	H1	H2	H3	D depth (not shown)	E (handle)	Weight <sup>2</sup> (kgs)
				ISO/NPT	ISO/NPT						
FUR3.A_	15	1/2	0.28 0.51 0.86 2.1 3.7 6.9	68.6	177.8	86.4	241.3	50.8	76.2	50.8	0.7
FUR3.B_	20	3/4	0.34 0.57 1.1 2.1 3.3 9.5	71.1	165.1	86.4	226.1	50.8	76.2	50.8	0.7
FUR3.C_	25	1	0.34 0.56 1.1 2.0 3.0 8.6	71.1	185.4	86.4	243.8	53.3	76.2	50.8	0.7
			7.4 19.2	76.2	172.7	99.1	251.5	61.0			1.0
			3.9 12.8 26.6	109.2	198.1	104.1	276.9	83.8			1.6
FUR3.D_	32	1 1/4	3.5 7.5 16.7	76.2	172.7	99.1	251.5	61.0	76.2	50.8	1.5
			11.0 23.1 29.4	91.4	185.4	104.1	264.2	71.1			1.6
FUR3.E_	40	1 1/2	3.5 7.2 11.6 27.6	86.4	198.1	104.1	276.9	68.6	76.2	50.8	1.6
			20.3 52.7	101.6	185.4	116.8	281.9	81.3			2.4
FUR3.F_	50	2	20.6 32.9 48.9	101.6	185.4	116.8	281.9	81.3	76.2	50.8	2.4
			71.2 95.5	127.0	198.1	149.9	315.0	96.5			3.9
FUR3.G_	65	2 1/2	32.8 63.9 85.8	134.6	198.1	149.9	315.0	104.1	76.2	50.8	4.1
FUR3.H_	80 <sup>3</sup>	3 <sup>3</sup>	64.7 86.2 107.8 129.3 150.9 172.4	238.8	256.5	114.3	312.4	71.1	180.3	50.8	10.0

Note 2: The weight is without actuator.

Note 3: Valve shown is 15mm to 65mm. 80mm valve has bypass port in Z plane.

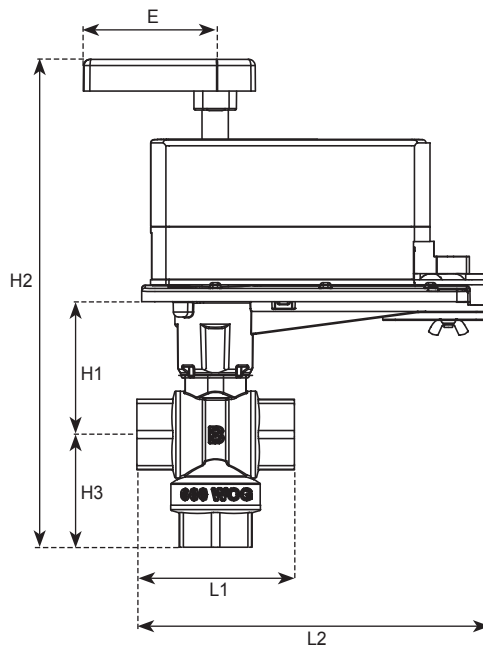

## MODEL NUMBER SELECTION

**FUR3** . . . . .

**M** . . . . .

Insert ball size:

**A**=15mm, 1/2"   **B**=20mm, 3/4"   **C**=25mm, 1"   **D**=32mm, 1 1/4"  
**E**=40mm, 1 1/2"   **F**=50mm, 2"   **G**=65mm, 2 1/2"   **H**=80mm, 3"

Insert a Kv value (**A, B, C, D, E, F, G, H, J, K or M**) (see flow rate table next page):

Select connection standard:

**I**=ISO   **N**=NPT (NPT only available ex. US-factory)

Select ball and stem:

**B**=Standard   **S**=Optional 316 SS   **C**=Standard ball with SS stem

Insert mounting kit number:

**1**=FlowCon  
**2**=Johnson Controls  
**3**=Invensys  
**4**=Honeywell  
**5**=Siemens  
**6**=Belimo  
**7**=KMC Controls

Insert power supply, actuator:

**0**=if no actuator required  
**10**=24V 2-position or 3-point floating (without end switches) (BBTS1000)  
**20**=240V 2-position or 3-point floating (without end switches) (BBTHV1200A)  
**30**=24V modulating (without end switches) (BBMS2000)  
**40**=24V 2-position or 3-point floating incl. auxiliary switches (BBTS1021)  
**50**=240V 2-position or 3-point floating incl. auxiliary switches (BBTHV1221A)  
**60**=24V modulating incl. auxiliary switches (BBMS2021)

**T**=Optional aluminum hanging ID tag

Example: FUR3.A.C.I.B.M.1.10.T=Unimizer 3-way 15mm (Kv equal to 0.86 m³/h) with ISO end connections, standard ball and stem, FlowCon mounting kit, 24V 2-position actuator and ID-tag.

## Kv SELECTION AND FLOW RATE TABLE (l/h)

Line size (mm)	Model no	Full <sup>4</sup> port	Close OFF $\Delta P^5$ (bar)	Flow rate (l/h) differential pressure (kPa) across valve												Kv <sup>6</sup> (m <sup>3</sup> /h)	Through Kv
				5	10	15	20	25	30	40	50	60	70	80	90		
15	FUR3.A_		3.5	63	89	108	125	140	153	177	198	217	234	250	266	0.28	A
	FUR3.A_			114	161	198	228	255	279	323	361	395	427	456	484	0.51	B
	FUR3.A_			192	272	333	385	430	471	544	608	666	720	769	816	0.86	C
	FUR3.A_			463	655	802	926	1035	1134	1309	1464	1603	1732	1851	1964	2.07	D
	FUR3.A_			830	1173	1437	1659	1855	2032	2346	2623	2874	3104	3318	3520	3.71	E
	FUR3.A_			1543	2182	2672	3086	3450	3779	4364	4879	5345	5773	6172	6546	6.90	F
20	FUR3.B_		3.5	76	108	132	152	170	186	215	240	263	284	304	323	0.34	A
	FUR3.B_			127	180	221	255	285	312	360	403	442	477	510	541	0.57	B
	FUR3.B_			25	35	43	50	56	61	71	79	87	94	100	106	0.11	C
	FUR3.B_			463	655	802	926	1035	1134	1309	1464	1603	1732	1851	1964	2.07	D
	FUR3.B_			733	1037	1270	1467	1640	1797	2074	2319	2541	2744	2934	3112	3.28	E
	FUR3.B_	•		2120	2998	3672	4240	4740	5192	5996	6703	7343	7932	8479	8994	9.48	F
25	FUR3.C_		3.5	76	108	132	152	170	186	215	240	263	284	304	323	0.34	A
	FUR3.C_			125	177	217	250	280	307	354	396	434	469	501	531	0.56	B
	FUR3.C_			250	354	434	501	560	613	708	792	868	937	1002	1063	1.12	C
	FUR3.C_			443	626	767	885	990	1084	1252	1400	1534	1657	1771	1878	1.98	D
	FUR3.C_			675	955	1170	1351	1510	1654	1910	2135	2339	2527	2701	2865	3.02	E
	FUR3.C_			1927	2726	3339	3855	4310	4721	5452	6095	6677	7212	7710	8178	8.62	F
	FUR3.C_			1657	2343	2870	3314	3705	4059	4686	5240	5740	6200	6628	7030	7.41	G
	FUR3.C_			4298	6078	7444	8595	9610	10527	12156	13591	14888	16081	17191	18234	19.22	H
	FUR3.C_			2871	4060	4973	5742	6420	7033	8121	9079	9946	10743	11484	12181	12.84	J
	FUR3.C_			868	1227	1503	1735	1940	2125	2454	2744	3005	3246	3470	3681	3.88	K
	FUR3.C_			5937	8396	10283	11874	13275	14542	16792	18774	20566	22213	23747	25188	26.55	M
32	FUR3.D_	•	3	3739	5287	6476	7477	8360	9158	10575	11823	12951	13989	14955	15862	16.72	B
	FUR3.D_			2448	3463	4241	4897	5475	5998	6925	7743	8482	9161	9794	10388	10.95	C
	FUR3.D_			792	1119	1371	1583	1770	1939	2239	2503	2742	2962	3166	3358	3.54	D
	FUR3.D_			1677	2372	2905	3354	3750	4108	4743	5303	5809	6275	6708	7115	7.50	E
	FUR3.D_	•		6574	9297	11387	13148	14700	16103	18594	20789	22773	24598	26296	27891	29.40	F
	FUR3.D_			5165	7305	8947	10331	11550	12652	14610	16334	17893	19327	20661	21915	23.10	G
40	FUR3.E_		3	2583	3652	4473	5165	5775	6326	7305	8167	8947	9663	10331	10957	11.55	A
	FUR3.E_			771	1091	1336	1543	1725	1890	2182	2440	2672	2886	3086	3273	3.45	B
	FUR3.E_			1601	2264	2773	3202	3580	3922	4528	5063	5546	5990	6404	6793	7.16	C
	FUR3.E_	•		6169	8725	10686	12339	13795	15112	17449	19509	21371	23083	24677	26174	27.59	D
	FUR3.E_			4530	6407	7847	9061	10130	11097	12814	14326	15693	16951	18121	19220	20.26	E
	FUR3.E_			11777	16656	20399	23555	26335	28849	33311	37243	40798	44067	47109	49967	52.67	F
50	FUR3.F_		3	4606	6514	7978	9213	10300	11283	13029	14566	15957	17235	18425	19543	20.60	A
	FUR3.F_			10930	15457	18931	21860	24440	26773	30914	34563	37862	40896	43720	46372	48.88	B
	FUR3.F_			7363	10413	12754	14727	16465	18037	20827	23285	25507	27551	29453	31240	32.93	C
	FUR3.F_			20914	29577	36224	41828	46765	51228	59154	66136	72448	78253	83656	88730	93.53	D
	FUR3.F_			15923	22519	27580	31846	35605	39003	45037	50353	55159	59579	63692	67556	71.21	E
65	FUR3.G_		3	7343	10385	12719	14686	16420	17987	20770	23221	25438	27476	29373	31155	32.84	A
	FUR3.G_			14284	20201	24741	28568	31940	34989	40401	45170	49481	53446	57136	60602	63.88	B
	FUR3.G_	•		19181	27126	33222	38362	42890	46984	54252	60656	66445	71769	76724	81378	85.78	C
80	FUR3.H_		5	14458	20447	25043	28917	32330	35416	40895	45722	50085	54098	57834	61342	64.66	A
	FUR3.H_			19277	27262	33389	38554	43105	47219	54524	60960	66778	72128	77109	81786	86.21	B
	FUR3.H_			24096	34077	41735	48192	53880	59023	68153	76198	83471	90158	96383	102230	107.76	C
	FUR3.H_			28915	40891	50082	57829	64655	70826	81783	91436	100163	108189	115658	122674	129.31	D
	FUR3.H_			33733	47706	58428	67467	75430	82629	95412	106674	116856	126219	134933	143118	150.86	E
	FUR3.H_	•		38552	54521	66774	77104	86205	94433	109042	121912	133548	144249	154208	163562	172.41	F

Note 4: These valves are full port and do not have the Optimizer insert.

Note 5: Close OFF pressures measured with 4 Nm actuator. The "Close OFF pressure" is the maximum allowable pressure drop across the valve body when the valve is fully closed. (Do not use actuators with torques higher than 10 Nm).

Note 6: Kv is defined as the quantity of water in m<sup>3</sup>/h at 15°C that will flow through a given valve with a pressure drop of 1 bar. Hence the 1.0 bar pressure differential column in the table above is equivalent to the Kv value.

## GENERAL SPECIFICATIONS

### 1. ACTUATED BALL VALVE

- 1.1. Valve housing shall consist of forged brass DZR CW602 rated at no less than 2400 kPa at +120°C.
- 1.2. Manufacturer shall be able to provide glass-filled polymer ball insert to make flow control equal percentage.
- 1.3. Valve ball shall consist of chemically nickel-plated brass.
- 1.4. Valve shall have EPDM O-Rings behind ball seals to allow for a minimum close-off pressure of 275 kPa with 4 Nm of torque for 15mm-50mm sizes.
- 1.5. Bypass Kv shall be 80% of through Kv.
- 1.6. Stem shall be removable/replaceable without removing valve from line and shall include both teflon seals and EPDM O-ring.
- 1.7. Valves shall be installed in Tee configuration with actuator perpendicular to shaft. Valve shall not require elbows of any kind.

### 2. VALVE ACTUATOR

- 2.1. Control valve actuator shall be analog modulating (4-20 mA or 2-10 V), floating (tri-state), pulse width modulation, or two position as indicated in the control sequence.
- 2.2. Actuator shall provide minimum torque required for full valve shutoff position.
- 2.3. A 90 cm cable shall be provided for installation to electrical junction box.
- 2.4. A universal mounting plate shall allow installation of actuators meeting the system electrical requirements and valve torque requirements as provided by FlowCon, Belimo, ELO Drive, Honeywell, Invensys, Johnson Controls, KMC, Neptronics or Siemens. The control valve actuator may be furnished by the controls contractor under Section 15970 or by the valve manufacturer.

### 3. ACCESSORIES

- 3.1. Identification tags shall be available for all valves; tags shall be indelibly marked with Kv, model number and location; tags shall be aluminum.

## UPDATES

**For latest updates please see [www.flowcon.com](http://www.flowcon.com)**

FlowCon International can accept no responsibility for possible errors in any printed material.  
All rights reserved.

# FlowCon Unimizer 3-way 100-150mm

## Actuated Control Valves

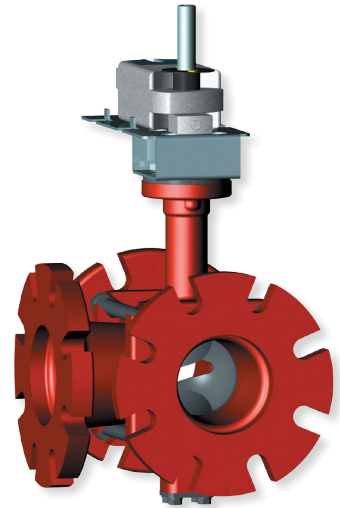

### SPECIFICATIONS

Pressure rating:	1600 kPa / 240 psi
Temperature rating, media:	-20°C to +120°C / -4°F to +248°F
Temperature rating, ambient:	-20°C to +50°C / -4°F to +122°F
Media:	Chilled water, hot water (Fluid grp. 2) For higher glycol content than 50% or additional fluids, please consult factory
Material:	
- Body:	Cast iron ASTM A395, 60-40-18
- End connections:	EN 1092-1 flanges
- Stem:	Stainless steel
- Stem seals:	EPDM o-rings
- Ball valve:	Stainless steel
- Ball seals:	Teflon seals
Angle of rotation:	0-90°
Leakage:	Bypass port has IEC 60534-1 Class III Leakage rate when valve is in straight through position <sup>1</sup>

Note 1: Bypass flow leakage rate based on largest Kv of the ball

## DIMENSIONS AND WEIGHTS (NOMINAL) (measured in mm unless noted)

Model no.	Size (mm)	Size (")	Kv (m <sup>3</sup> /h)	L1	L2 <sup>2</sup>	H1	H2	D depth (not shown)	Weight <sup>3</sup> (kgs)
F3WR.J_	100	4	78 102 131 170 219 282	302	363	229	493	267	34.0
F3WR.K_	125	5	124 159 207 266 345	353	389	254	516	305	40.8
F3WR.L_	150	6	179 231 298 380 497 560	404	414	279	544	340	47.6

Note 2: L2 is maximum length, which is measured from end flange or mounting plate, whichever extends farther.  
 Note 3: The weight is without actuator.

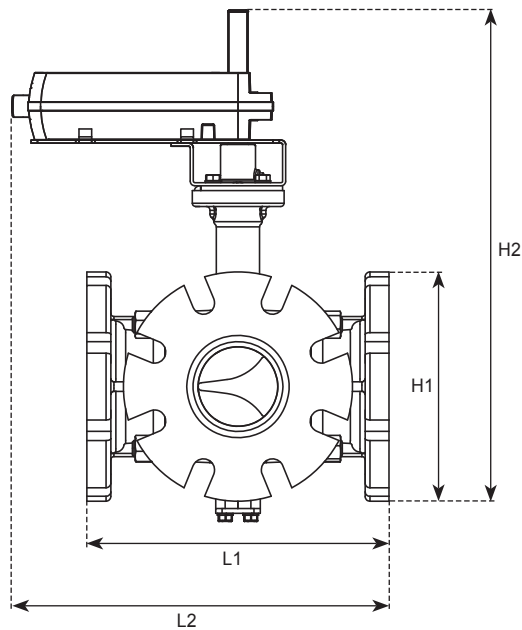

## FLANGE MATCH UNIMIZER

Model no.	Unimizer DN (mm)	EN 1092-1:2007 flanges			
		PN 10	PN 16	PN 25	PN 40
F3WR.J_	100	✓	✓	✓	✓
F3WR.K_	125	✓	✓	✓	✓
F3WR.L_	150	✓	✓	✓	✓

## MODEL NUMBER SELECTION

F3WR . . . . . L . S . M . . . . .

Insert ball size:

**J**=100mm, 4" **K**=125mm, 5" **L**=150mm, 6"

Insert a Kv value (**A, B, C, D, E** or **F**) (see flow rate table below):

Insert mounting kit number:

**1**=FlowCon  
**4**=Honeywell  
**5**=Siemens

Insert power supply, actuator:

**0**=if no actuator required  
**10**=24V 2-position or 3-point floating (without end switches) (TT000)  
**20**=240V 2-position or 3-point floating (without end switches) (TT300)  
**40**=24V 2-position or 3-point floating incl. auxiliary switches (TT020)  
**50**=240V 2-position or 3-point floating incl. auxiliary switches (TM300)  
**60**=24V modulating incl. auxiliary switches (TM000)

**T**=Optional aluminum hanging ID tag

Example: F3WR.J.C.L.S.M.1.10.T=Unimizer 3-way 100mm (Kv equal to 131 m<sup>3</sup>/h) with FlowCon mounting kit, 24V 2-position actuator and ID-tag.

## Kv SELECTION AND FLOW RATE TABLE (l/h)

Line size (mm)	Model no	Close OFF $\Delta P^4$ (bar)	Flow rate (l/h) differential pressure (kPa) across valve											Kv <sup>5</sup> m <sup>3</sup> /h	Kv for model no. selection	
			5	10	15	20	25	30	40	50	60	70	80			90
100	F3WR.J.A_	5	17350	24536	30050	34699	38795	42498	49072	54864	60101	64916	69399	73608	78	A
	F3WR.J.B_		22748	32170	39400	45495	50865	55720	64340	71934	78800	85113	90990	96510	102	B
	F3WR.J.C_		29299	41435	50748	58598	65515	71768	82871	92652	101495	109628	117197	124306	131	C
	F3WR.J.D_		37975	53705	65775	75950	84915	93020	107410	120088	131550	142090	151901	161115	170	D
	F3WR.J.E_		48970	69254	84818	97940	109500	119951	138508	154856	169637	183229	195880	207762 <sup>6</sup>	219	E
	F3WR.J.F_		63035	89145	109179	126070	140950	154403	178289	199333	218359 <sup>6</sup>	235854 <sup>6</sup>	252139 <sup>6</sup>	-	282	F
125	F3WR.K.A_	5	27759	39257	48079	55517	62070	67994	78513	87780	96158	103863	111034	117770	124	A
	F3WR.K.B_		35665	50438	61774	71331	79750	87362	100877	112784	123548	133447	142661	151315	159	B
	F3WR.K.C_		46264	65428	80132	92528	103450	113324	130855	146300	160264	173105	185057	196283	207	C
	F3WR.K.D_		59569	84243	103176	119138	133200	145913	168486	188373	206353 <sup>6</sup>	222886 <sup>6</sup>	238275 <sup>6</sup>	-	266	D
	F3WR.K.E_		77106	109045	133552	154213	172415	188871	218090 <sup>6</sup>	243832 <sup>6</sup>	267104 <sup>6</sup>	288505 <sup>6</sup>	308425 <sup>6</sup>	-	345	E
150	F3WR.L.A_	5	40093	56700	69443	80185	89650	98207	113399	126784	138885	150013	160371	170099	179	A
	F3WR.L.B_		51653	73049	89466	103306	115500	126524	146097	163342	178932	193268	206613 <sup>6</sup>	219146 <sup>6</sup>	231	B
	F3WR.L.C_		66702	94331	115531	133404	149150	163386	188661	210930 <sup>6</sup>	231062 <sup>6</sup>	249576 <sup>6</sup>	266808 <sup>6</sup>	282992 <sup>6</sup>	298	C
	F3WR.L.D_		85015	120230	147251	170031	190100	208244 <sup>6</sup>	240460 <sup>6</sup>	268842 <sup>6</sup>	294502 <sup>6</sup>	318098 <sup>6</sup>	-	-	380	D
	F3WR.L.E_		111222	157292	192642	222444 <sup>6</sup>	248700 <sup>6</sup>	272437 <sup>6</sup>	-	-	-	-	-	-	497	E
	F3WR.L.F_		125287	177182	217003 <sup>6</sup>	250574 <sup>6</sup>	-	-	-	-	-	-	-	-	560	F

Note 4: Close OFF pressures measured with 10 Nm actuator for 100-125mm valves. Close OFF pressures measured with 15 Nm actuator for 150mm valve, up to 159000 l/h. For flowrates greater than 159000 l/h a 22 Nm actuator is recommended.

The "Close OFF pressure" is the maximum allowable pressure drop across the valve body when the valve is fully closed.

Note 5: Kv is defined as the quantity of water in m<sup>3</sup>/h at 15°C that will flow through a given valve with a pressure drop of 1 bar.

Hence the 1.0 bar pressure differential column in the table above is equivalent to the Kv value.

Note 6: Due to high velocity, flowrates of 204500 l/h and higher may result in water noise.

## GENERAL SPECIFICATIONS

### 1. ACTUATED BALL VALVE

- 1.1. Valve housing shall consist of cast iron ASTM A395, 60-40-18 rated at no less than 1600 kPa at +120°C. Valve housing shall have EN 1092-1 flanges.
- 1.2. Valve ball shall consist of stainless steel with parabolic ports to make flow control equal percentage.
- 1.3. Valve shall have a blow-out proof stem with two EPDM O-Rings.
- 1.4. Valve shall have EPDM O-Rings behind ball seals to allow for a minimum close-off pressure of 480 kPa with 10 Nm of torque for 100mm and 125mm valves. 150mm valves shall require actuators with 15 Nm of torque for flowrates under 159000 l/h.
- 1.5. Bypass Kv shall be 80% of through Kv.

### 2. VALVE ACTUATOR

- 2.1. Control valve actuator shall be analog modulating (4-20 mA or 2-10 V), floating (tri-state), pulse width modulation, or two position as indicated in the control sequence.
- 2.2. Actuator shall provide minimum torque required for full valve shutoff position.
- 2.3. A 0.9 m cable shall be provided for installation to electrical junction box.
- 2.4. A universal mounting plate shall allow installation of actuators meeting the system electrical requirements and valve torque requirements as provided by FlowCon, Honeywell, Neptronics or Siemens.  
The control valve actuator may be furnished by the controls contractor under Section 15970 or by the valve manufacturer.

### 3. ACCESSORIES

- 3.1. Identification tags shall be available for all valves; tags shall be indelibly marked with Kv, model number and location; tags shall be aluminum.

## UPDATES

**For latest updates please see [www.flowcon.com](http://www.flowcon.com)**

FlowCon International can accept no responsibility for possible errors in any printed material.  
All rights reserved.

# FlowCon A / AB / ABV

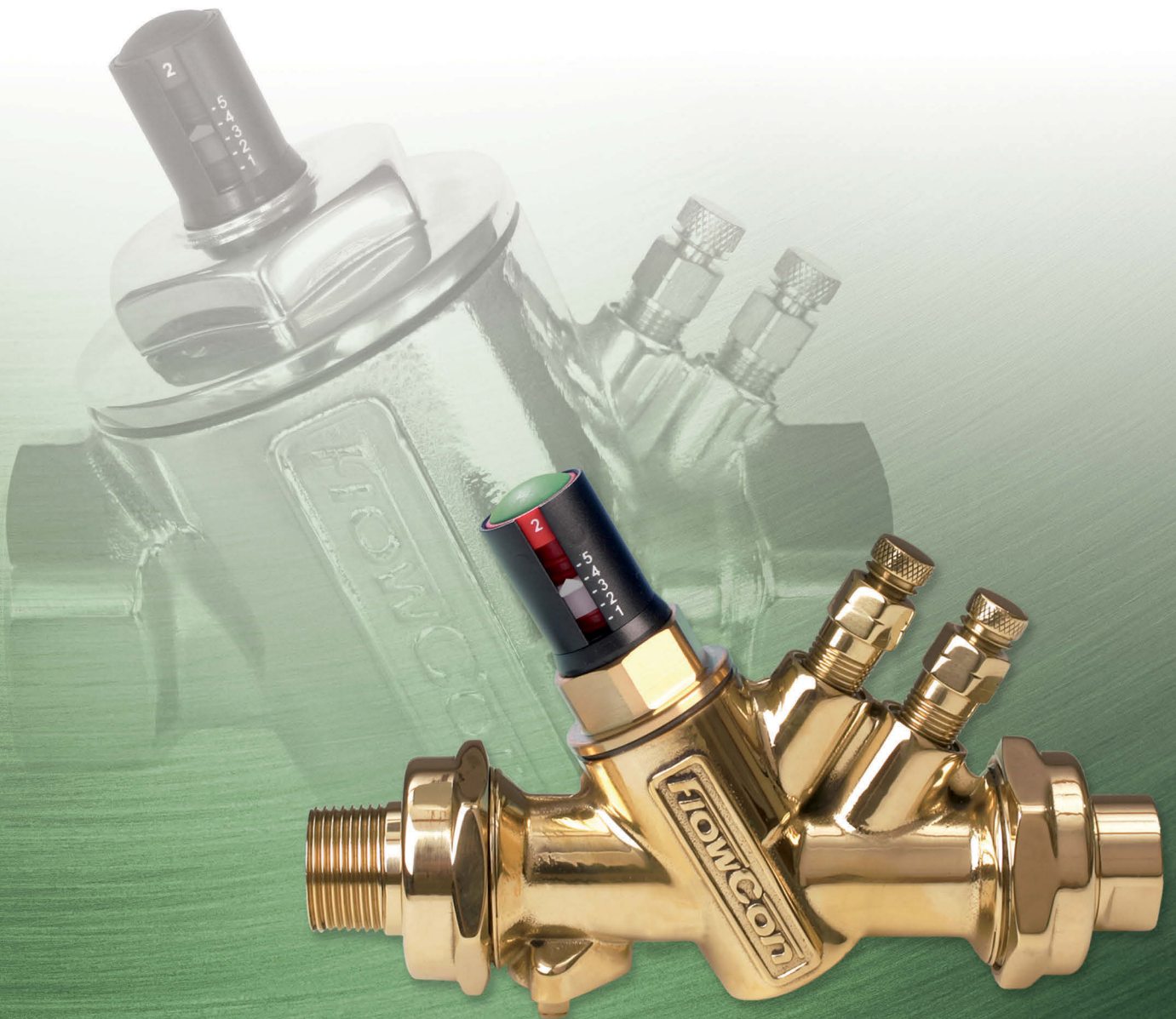

*The “Adjustable” Automatic Flow Control Valves*

# FlowCon A, AB and ABV

*Dynamic Balancing Valve with Adjustable Flow Insert*



The FlowCon A, AB and ABV automatic balancing valves are designed for balancing heating and air-conditioning terminal units by providing a constant flow rate with the added feature of being adjustable.

With these automatic balancing valves flow can be controlled with one of two different inserts; either an internal composite insert or an externally adjustable E-JUST insert. Both insert-types keep the flow rate constant, even with system pressure conditions changing.

The main difference between these and other automatic balancing valves is that each flow control insert can be easily adjusted to a new flow rate if necessary.

## **Standard Composite Insert**

The standard composite insert is easily removed from the valve body and adjusted to one of eight different flow rates by means of a Hex key. There are 14 different adjustable inserts, totalling nearly 100 different flow rates available for valve sizes 15mm through 40mm.

## **E-JUST Insert**

The E-JUST insert can be externally adjusted to one of 41 flow rates even when the system is operating. The E-JUST insert is tamper-proof since adjustment is carried out by means of a special FlowCon key. Further the setting can be sealed with a top cover.

## **Stainless Steel Insert**

Alternatively, a factory pre-set stainless steel insert can be used together with an adaptor. These inserts are single flow inserts, but exchanging of the insert and adaptor is straight forward.

## **Features and Benefits**

- **Automatic balancing**, the correct flow rate for each circuit is achieved automatically.
- **Dynamic balancing**, the correct flow rate is maintained as each valve compensates for pressure fluctuations in the system.
- **Field adjustable**, flow rate can be changed on demand, either internally or externally adjustment or insert exchange.
- **Elimination of branch or "partner" balancing valves** which results in fewer total valves used in each project.
- **Easily accessible insert** for flow rate adjustment or maintenance.
- **Accuracy** of  $\pm 10\%$  or 20 l/hr (standard composite insert) alternatively  $\pm 5\%$  of controlled flow rate or  $\pm 2\%$  of maximum flow rate (E-JUST insert). For stainless steel inserts accuracy is  $\pm 5\%$ .
- **Built-in isolation ball valve** (FlowCon ABV).
- **Pressure/temperature measurement plugs** available for verifying operating differential pressure or checking  $\Delta T$  across the coil (FlowCon AB/ABV).
- **Double union end connection** for ease of installation and wide selection of end fittings (FlowCon ABV) or **fixed female threaded ends** (FlowCon A/AB).



**Principle of Insert Operation  
- FlowCon Composite  
and FlowCon E-JUST Inserts**

The flow control insert of FlowCon A/AB/ABV contains two interacting components; one that has an adjustable orifice, and one that regulates the pressure differential across the adjustable orifice.

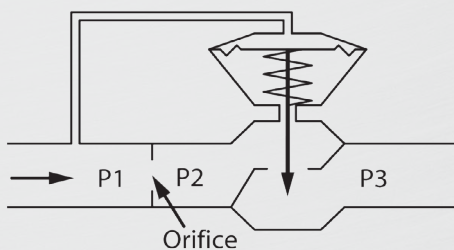

For the FlowCon A/AB/ABV, the principle of operation is shown above and the principle of construction is shown below. P1 and P3 are system pressures,  $P1+P3$  is the total pressure drop across the valve. P2 is set by the diaphragm acting in reaction to P1 in the upper diaphragm chamber. Interacting with the spring,  $P1+P2$  remains constant, keeping a constant  $\Delta P$  across the orifice areas. The result is a constant flow rate through the valve, independent of pressure fluctuations.

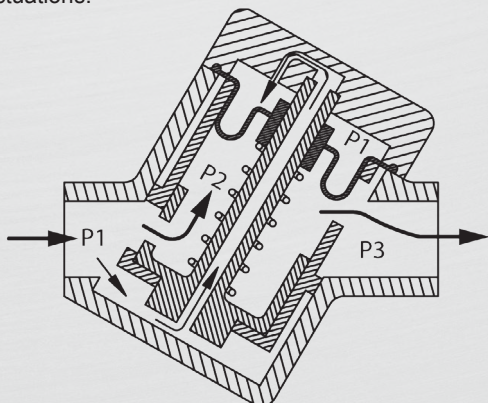

Below its pressure differential range, the valve acts as a fixed orifice. This allows a temperature control valve in the same circuit to operate with valve authority up to the set flow rate maximum.

In case the differential pressure is higher than the defined max.  $\Delta P$  for the insert, the diaphragm may be damaged.

**Principle of Insert Operation  
- Stainless Steel Inserts**

Below its pressure differential range the stainless steel insert acts as a fixed orifice. This allows a modulating valve in the same circuit to operate with valve authority up to the flow rate specified for the FlowCon A/AB/ABV.

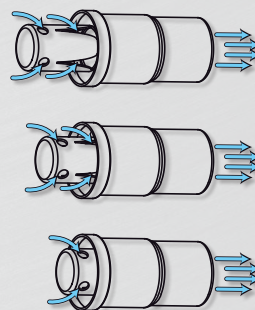

Within operating pressure differential range, the effective open orifice area of the insert is automatically adjusted to the point where the specified flow rate will be delivered (as the pressure differential increases, the open area closes and as it decreases, the area opens).

When the pressure differential range is exceeded, the valve again becomes a fixed orifice device. This ensures that no part of the system is starved or shut down.

## Automatic vs. Manual System Layout Comparison

### Manually balanced system.

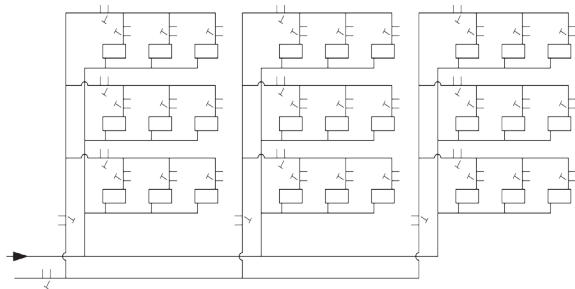

Total number of valves (manual) 40.

In addition to terminal unit valves, manual balancing requires "partner valves" located on the branches, raisers and main.

### Automatic balanced system.

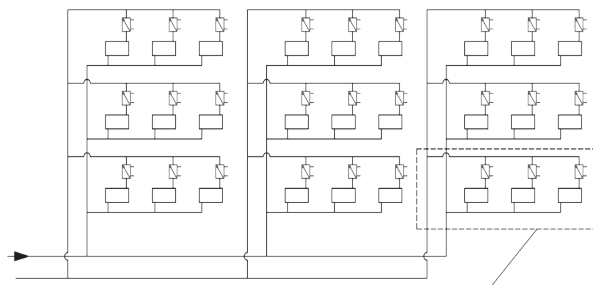

Total number of valves (automatic) 27.

Each branch is automatically balanced due to the correct balance of each coil. Sum total of 0.31 l/sec (branch).

NOTE: The location of the FlowCon A/AB/ABV does not require lengths of pipe before or after the valve.

### Technical Data

For further information and part number selection please see FlowCon tech note and the catalogue: FlowCon Inserts. For latest updates please see [www.flowcon.com](http://www.flowcon.com).

	A/AB DN15/20/25 ABV DN15/20/25	AB DN25/32 ABV DN25/32/40	AB DN40/50
Static Pressure (kPa) (psi)	2500 360		
Temperature Rating (media/ambient) (°C) (°F)	-20 to +120 / 0 to +50 -4 to +248 / +32 to +122		
Pressure Drop Data	NOTE: For pump head calculations, add the minimum pressure differential for the index circuit to the other components pressure losses (i.e. valves, coil, etc.)		
Valve Body (Kv-value) (Cv-value)	3.1 3.6	12.5 14.5	23.0 30.4

Stainless Steel Insert	F3601xx	F3602xx	F3604xx	F3608xx	F3611xx	F3612xx	F3614xx	F3618xx	N/A
Insert Size (mm) (inch)	20 3/4"	20 3/4"	20 3/4"	20 3/4"	40 1 1/2"	40 1 1/2"	40 1 1/2"	40 1 1/2"	
Pressure (kPaD) Differential (psid)	10-95 1-14	22-210 2-32	40-390 4-57	90-880 8-128	10-95 1-14	22-210 2-32	40-390 4-57	90-880 8-128	
Flow Rate (l/sec) (GPM)	0.0210-0.315 0.333-5.00	0.0347-0.505 0.550-8.00	0.0473-0.631 0.750-10.0	0.0694-1.01 1.10-16.0	0.189-0.925 3.00-14.7	0.284-1.39 4.50-22.0	0.379-1.85 6.00-29.3	0.568-2.78 9.00-44.0	

Standard Composite Insert	ABV1.Y.x grey/red/blue/black/green	ABV1.G.x grey/red/blue/black/green	ABV2.X.x red/white	ABV2.C.x red/white	ABV2.D.x red/white	N/A
Insert Size (mm) (inch)	20 3/4"	20 3/4"	40 1 1/2"	40 1 1/2"	40 1 1/2"	
Pressure (kPaD) Differential (psid)	15-130 2.2-18.9	30-400 4.4-58	15-130 2.2-18.9	22-300 3.2-43.5	30-410 4.4-59.5	
Flow Rate (l/sec) (GPM)	0.0081-0.273 0.128-4.33	0.0767-0.229 0.185-6.46	0.117-0.408 2.69-13.5	0.23-1.21 3.65-19.2	0.27-1.43 4.28-22.7	

E-JUST Insert	E-JUST1.Y.x black/green	E-JUST1.Y.R red	E-JUST1.G.R red	E-JUST1.G.x black/green	E-JUST2.Y.G green	E-JUST3.G.B black
Insert Size (mm) (inch)	20 3/4"	20 3/4"	20 3/4"	20 3/4"	40 1 1/2"	50 2"
Pressure (kPaD) Differential (psid)	17-210 2.5-30	17-200 2.5-29	30-400 4.4-58	35-400 5.1-58	17-400 2.5-58	20-400 2.9-58
Flow Rate (l/sec) (GPM)	0.0278-0.169 0.44-2.68	0.0767-0.229 1.22-3.60	0.113-0.352 1.79-5.57	0.0383-0.249 0.607-3.95	0.149-1.62 2.36-25.7	0.883-4.48 14.0-70.9

**FlowCon**  
international

A Griswold Controls LLC./FlowCon International Company

[www.flowcon.com](http://www.flowcon.com)

D E N M A R K · D U B A I · U S A · S I N G A P O R E

# FlowCon A 15-25mm

## *Dynamic Balancing Valve - Adjustable Insert*



### SPECIFICATIONS

Pressure rating:	2500 kPa / 360 psi
Temperature rating, media:	-20°C to +120°C / -4°F to +248°F
Material:	
- Insert:	Composite inserts: POM (Polyoxymethylene) E-JUST inserts: PSU (Polysulfone)
- Diaphragm:	Hydrogenated acrylonitrile-butadiene-rubber or EPDM depending on type
- Body:	Forged brass ASTM CuZn40Pb2
- O-rings:	EPDM
End connections:	Fixed female ISO or NPT (DN25 is only available in ISO)
Flow rate range:	0.0081-0.408 l/sec (standard composite insert) 0.0278-0.352 l/sec (E-JUST insert)

## DIMENSIONS AND WEIGHTS (NOMINAL) (measured in mm unless noted)

Valve size	Insert size	L	H1	H2	H3	Weight (kgs.)	Kv <sup>1</sup> (m <sup>3</sup> /hr)
15	20	80	31	50	80	0.58	3.1
20						0.53	
25		91				0.56	

Note 1: For valve body.

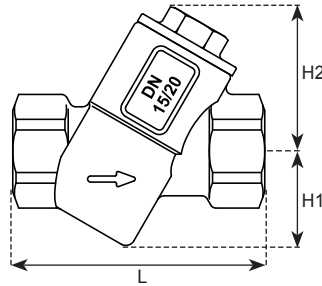

FlowCon A with composite insert

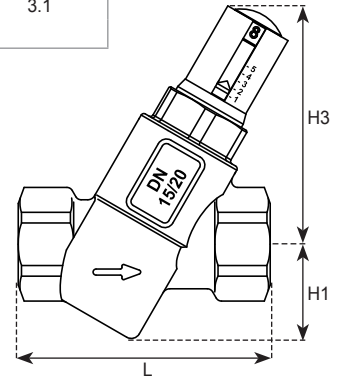

FlowCon A with E-JUST insert

## MODEL NUMBER SELECTION<sup>2</sup>

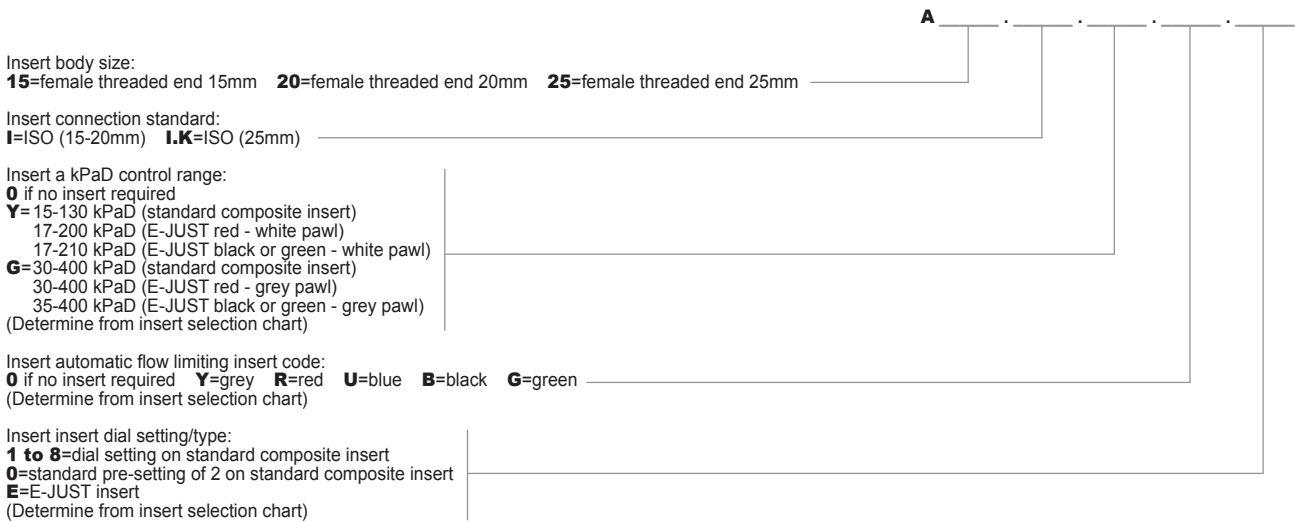

Example: A20.I.Y.Y.0=A 20mm ISO female threaded body with a Y-type grey standard composite insert - pre-setting 2.

Note 2: Flow rate, color and dial setting of insert are indicated on label affixed to body.

## FLOW RATE SETTING - COMPOSITE INSERT - FOR VALVES DN15-DN25

20mm · 3/4" · composite insert · Y-type								
Pressure range, ΔP: 20-130 kPaD (15-130 kPaD)* · 2.9-18.9 psid (2.2-18.9 psid)*								
Nominal flow rate	Model no.			ABV1.Y.Y	ABV1.Y.R	ABV1.Y.U	ABV1.Y.B	ABV1.Y.G
	l/sec	l/hr	GPM	Grey*	Red	Blue	Black	Green
	0.0081	29.2	0.128	1				
	0.0133	47.9	0.211	2				
	0.0175	63.0	0.277	3				
	0.0222	79.9	0.352	4				
	0.0311	112	0.493	5				
	0.0353	127	0.560	6				
	0.0383	138	0.607	7				
	0.0431	155	0.683	8				
	0.0450	162	0.713				3	
	0.0575	207	0.911		4			
	0.0619	223	0.981			4		
	0.0669	241	1.06				4	
	0.0922	332	1.46		5			
	0.0978	352	1.55					1
	0.105	378	1.66		6			
	0.114	409	1.80		7			
	0.115	415	1.83			5		
	0.118	426	1.88					2
	0.119	430	1.89		8			
	0.136	489	2.15					3
	0.137	492	2.17			6		
	0.138	498	2.19					4
	0.146	524	2.31			7		
	0.146	526	2.32			8		
	0.155	557	2.45				5	
	0.176	635	2.80				6	
	0.180	647	2.85				7	
	0.193	695	3.06				8	
	0.231	830	3.66					5
	0.237	854	3.76					6
	0.253	909	4.00					7
	0.273	984	4.33					8

Accuracy: Greatest of either ±10% of controlled flow rate or 20 l/hr (0.0056 l/sec or 0.088 GPM).

20mm · 3/4" · composite insert · G-type								
Pressure range, ΔP: 40-400 kPaD (30-400 kPaD)* · 5.8-58 psid (4.4-58 psid)*								
Nominal flow rate	Model no.			ABV1.G.Y	ABV1.G.R	ABV1.G.U	ABV1.G.B	ABV1.G.G
	l/sec	l/hr	GPM	Grey*	Red	Blue	Black	Green
	0.0117	42.1	0.185	1				
	0.0189	68.0	0.300	2				
	0.0247	88.9	0.392	3				
	0.0325	117	0.515	4				
	0.0472	170	0.748	5				
	0.0528	190	0.837	6				
	0.0564	203	0.894			3		
	0.0597	215	0.946				3	
	0.0639	230	1.01	7				
	0.0694	250	1.10	8				
	0.0781	281	1.24		4			
	0.0908	327	1.44			4		
	0.0958	345	1.52				4	
	0.137	493	2.17		5			
	0.147	529	2.33					1
	0.161	581	2.56		6			
	0.173	624	2.75		7			
	0.181	652	2.87			5		
	0.181	653	2.88		8			
	0.186	670	2.95					2
	0.210	755	3.32					3
	0.216	779	3.43			6		
	0.218	785	3.46			7		
	0.220	792	3.49			8		
	0.237	853	3.75				5	
	0.241	869	3.83					4
	0.266	957	4.21				6	
	0.269	968	4.26				7	
	0.277	998	4.39				8	
	0.365	1320	5.79					5
	0.369	1330	5.85					6
	0.392	1410	6.21					7
	0.408	1470	6.46					8

Accuracy: Greatest of either ±10% of controlled flow rate or 20 l/hr (0.0056 l/sec or 0.088 GPM).



## FLOW RATE SETTING - E-JUST INSERT - FOR VALVES DN15-DN25

20mm · 3/4" · E-JUST · Y-type · White pawl					
Pressure range, ΔP: 17-210 kPaD · 2.5-30 psid					
Nominal flow rate	Model no.			E-JUST1.Y.B	E-JUST1.Y.G
	l/sec	l/hr	GPM	Black	Green
				Setting	Setting
	0.0278	100	0.440	1.0	
	0.0299	108	0.475	1.1	
	0.0321	116	0.509	1.2	
	0.0343	123	0.543	1.3	
	0.0364	131	0.578	1.4	
	0.0386	139	0.612	1.5	
	0.0408	147	0.646	1.6	
	0.0429	155	0.681	1.7	
	0.0436	157	0.691		1.0
	0.0451	162	0.715	1.8	
	0.0468	168	0.741		1.1
	0.0473	170	0.749	1.9	
	0.0494	178	0.784	2.0	
	0.0499	180	0.791		1.2
	0.0516	186	0.818	2.1	
	0.0530	191	0.841		1.3
	0.0538	194	0.852	2.2	
	0.0559	201	0.887	2.3	
	0.0562	202	0.890		1.4
	0.0581	209	0.921	2.4	
	0.0593	214	0.940		1.5
	0.0603	217	0.955	2.5	
	0.0624	225	0.990	2.6	1.6
	0.0646	233	1.02	2.7	
	0.0656	236	1.04		1.7
	0.0668	240	1.06	2.8	
	0.0687	247	1.09		1.8
	0.0689	248	1.09	2.9	
	0.0711	256	1.13	3.0	
	0.0719	259	1.14		1.9
	0.0733	264	1.16	3.1	
	0.0750	270	1.19		2.0
	0.0754	272	1.20	3.2	
	0.0776	279	1.23	3.3	
	0.0781	281	1.24		2.1
	0.0798	287	1.26	3.4	
	0.0813	293	1.29		2.2
	0.0819	295	1.30	3.5	
	0.0841	303	1.33	3.6	
	0.0844	304	1.34		2.3
	0.0863	311	1.37	3.7	
	0.0876	315	1.39		2.4
	0.0884	318	1.40	3.8	

Continue next column...

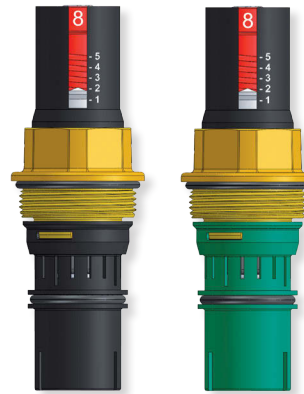

20mm · 3/4" · E-JUST · Y-type · White pawl					
Pressure range, ΔP: 17-210 kPaD · 2.5-30 psid					
Nominal flow rate	Model no.			E-JUST1.Y.B	E-JUST1.Y.G
	l/sec	l/hr	GPM	Black	Green
				Setting	Setting
	0.0906	326	1.44	3.9	
	0.0907	327	1.44		2.5
	0.0928	334	1.47	4.0	
	0.0938	338	1.49		2.6
	0.0949	342	1.50	4.1	
	0.0970	349	1.54		2.7
	0.0971	350	1.54	4.2	
	0.0993	357	1.57	4.3	
	0.100	360	1.59		2.8
	0.101	365	1.61	4.4	
	0.103	372	1.64		2.9
	0.104	373	1.64	4.5	
	0.106	381	1.68	4.6	
	0.106	383	1.69		3.0
	0.108	389	1.71	4.7	
	0.110	394	1.74		3.1
	0.110	396	1.75	4.8	
	0.112	404	1.78	4.9	
	0.113	406	1.79		3.2
	0.114	412	1.81	5.0	
	0.116	417	1.84		3.3
	0.119	428	1.89		3.4
	0.122	440	1.94		3.5
	0.125	451	1.98		3.6
	0.128	462	2.03		3.7
	0.132	473	2.08		3.8
	0.135	485	2.13		3.9
	0.138	496	2.18		4.0
	0.141	507	2.23		4.1
	0.144	519	2.28		4.2
	0.147	530	2.33		4.3
	0.150	541	2.38		4.4
	0.153	553	2.43		4.5
	0.157	564	2.48		4.6
	0.160	575	2.53		4.7
	0.163	586	2.58		4.8
	0.166	598	2.63		4.9
	0.169	609	2.68		5.0

Accuracy: Greatest of either ±5% of controlled flow rate or ±2% of maximum flow rate

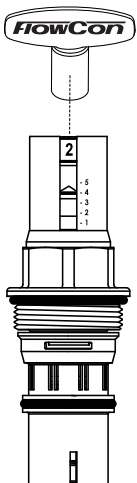

Use the FlowCon adjustment key (part number ACC0001) for adjusting the flow rate.

A setting of 4.2 corresponds to a flow rate of 0.144 l/sec for the 20mm green insert, range 17-210 kPaD.

## FLOW RATE SETTING - E-JUST INSERT - FOR VALVES DN15-DN25 (continued)

20mm · 3/4" · E-JUST · Y-type · White pawl				
Pressure range. ΔP: 17-200 kPaD · 2.5-29 psid				
Nominal flow rate	Model no.			E-JUST1.Y.R
	l/sec	l/hr	GPM	Red
				Setting
	0.0767	276	1.22	1.0
	0.0813	293	1.29	1.1
	0.0860	310	1.36	1.2
	0.0907	326	1.44	1.3
	0.0953	343	1.51	1.4
	0.100	360	1.58	1.5
	0.105	377	1.66	1.6
	0.109	393	1.73	1.7
	0.114	410	1.80	1.8
	0.118	426	1.88	1.9
	0.123	443	1.95	2.0
	0.128	459	2.02	2.1
	0.132	475	2.09	2.2
	0.136	491	2.16	2.3
	0.141	507	2.23	2.4
	0.145	523	2.30	2.5
	0.150	539	2.37	2.6
	0.154	554	2.44	2.7
	0.158	569	2.51	2.8
	0.162	584	2.57	2.9
	0.166	599	2.64	3.0
	0.170	614	2.70	3.1
	0.174	628	2.76	3.2
	0.178	642	2.83	3.3
	0.182	655	2.89	3.4
	0.186	669	2.94	3.5
	0.189	682	3.00	3.6
	0.193	695	3.06	3.7
	0.196	707	3.11	3.8
	0.200	719	3.17	3.9
	0.203	731	3.22	4.0
	0.206	742	3.27	4.1
	0.209	753	3.32	4.2
	0.212	764	3.36	4.3
	0.215	774	3.41	4.4
	0.218	784	3.45	4.5
	0.220	793	3.49	4.6
	0.223	802	3.53	4.7
	0.225	810	3.57	4.8
	0.227	818	3.60	4.9
	0.229	825	3.60	5.0

Accuracy: Greatest of either ±5% of controlled flow rate or ±2% of maximum flow rate

20mm · 3/4" · E-JUST · G-type · Grey pawl				
Pressure range. ΔP: 30-400 kPaD · 4.4-58 psid				
Nominal flow rate	Model no.			E-JUST1.G.R
	l/sec	l/hr	GPM	Red
				Setting
	0.113	406	1.79	1.0
	0.119	427	1.88	1.1
	0.125	449	1.98	1.2
	0.131	470	2.07	1.3
	0.137	492	2.17	1.4
	0.143	513	2.26	1.5
	0.149	535	2.36	1.6
	0.155	556	2.45	1.7
	0.161	578	2.54	1.8
	0.167	599	2.64	1.9
	0.172	621	2.73	2.0
	0.178	642	2.83	2.1
	0.184	664	2.92	2.2
	0.190	685	3.02	2.3
	0.196	707	3.11	2.4
	0.202	728	3.21	2.5
	0.208	750	3.30	2.6
	0.214	771	3.40	2.7
	0.220	793	3.49	2.8
	0.226	814	3.59	2.9
	0.232	836	3.68	3.0
	0.238	857	3.78	3.1
	0.244	879	3.87	3.2
	0.250	900	3.96	3.3
	0.256	922	4.06	3.4
	0.262	943	4.15	3.5
	0.268	965	4.25	3.6
	0.274	987	4.34	3.7
	0.280	1010	4.44	3.8
	0.286	1030	4.53	3.9
	0.292	1050	4.63	4.0
	0.298	1070	4.72	4.1
	0.304	1090	4.82	4.2
	0.310	1120	4.91	4.3
	0.316	1140	5.01	4.4
	0.322	1160	5.10	4.5
	0.328	1180	5.20	4.6
	0.334	1200	5.29	4.7
	0.340	1220	5.38	4.8
	0.346	1240	5.48	4.9
	0.352	1270	5.57	5.0

Accuracy: Greatest of either ±5% of controlled flow rate or ±2% of maximum flow rate

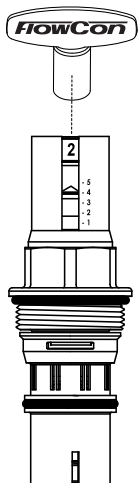
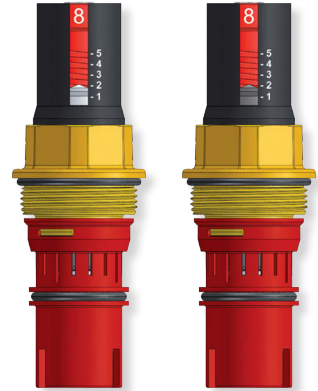

Use the FlowCon adjustment key (part number ACC0001) for adjusting the flow rate.

A setting of 4.2 corresponds to a flow rate of 0.304 l/sec for the 20mm red insert, range 30-400 kPaD.

## FLOW RATE SETTING - E-JUST INSERT - FOR VALVES DN15-DN25 (continued)

20mm · 3/4" · E-JUST · G-type · Grey pawl					
Pressure range, ΔP: 35-400 kPaD · 5.1-58 psid					
Nominal flow rate	Model no.			E-JUST1.G.B	E-JUST1.G.G
	l/sec	l/hr	GPM	Black	Green
				Setting	Setting
	0.0383	138	0.607	1.0	
	0.0416	150	0.660	1.1	
	0.0449	162	0.712	1.2	
	0.0483	174	0.765	1.3	
	0.0516	186	0.817	1.4	
	0.0549	198	0.870	1.5	
	0.0582	210	0.922	1.6	
	0.0615	221	0.975	1.7	
	0.0648	233	1.03	1.8	
	0.0660	238	1.05		1.0
	0.0681	245	1.08	1.9	
	0.0706	254	1.12		1.1
	0.0714	257	1.13	2.0	
	0.0748	269	1.18	2.1	
	0.0751	271	1.19		1.2
	0.0781	281	1.24	2.2	
	0.0797	287	1.26		1.3
	0.0814	293	1.29	2.3	
	0.0843	304	1.34		1.4
	0.0847	305	1.34	2.4	
	0.0880	317	1.40	2.5	
	0.0889	320	1.41		1.5
	0.0913	329	1.45	2.6	
	0.0934	336	1.48		1.6
	0.0946	341	1.50	2.7	
	0.0979	353	1.55	2.8	
	0.0980	353	1.55		1.7
	0.101	365	1.61	2.9	
	0.103	369	1.63		1.8
	0.105	377	1.66	3.0	
	0.107	386	1.70		1.9
	0.108	388	1.71	3.1	
	0.111	400	1.76	3.2	
	0.112	402	1.77		2.0
	0.115	412	1.82	3.3	
	0.116	419	1.84		2.1
	0.118	424	1.87	3.4	
	0.121	435	1.92		2.2
	0.121	436	1.92	3.5	
	0.124	448	1.97	3.6	
	0.125	452	1.99		2.3
	0.128	460	2.03	3.7	
	0.130	468	2.06		2.4
	0.131	472	2.08	3.8	

Continue next column...

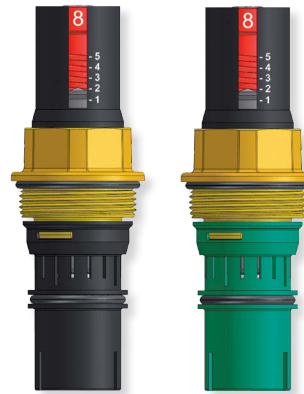

20mm · 3/4" · E-JUST · G-type · Grey pawl					
Pressure range, ΔP: 35-400 kPaD · 5.1-58 psid					
Nominal flow rate	Model no.			E-JUST1.G.B	E-JUST1.G.G
	l/sec	l/hr	GPM	Black	Green
				Setting	Setting
	0.134	484	2.13	3.9	
	0.135	485	2.13		2.5
	0.138	496	2.18	4.0	
	0.139	501	2.21		2.6
	0.141	508	2.24	4.1	
	0.144	517	2.28		2.7
	0.144	520	2.29	4.2	
	0.148	532	2.34	4.3	
	0.148	534	2.35		2.8
	0.151	544	2.39	4.4	
	0.153	550	2.42		2.9
	0.154	556	2.45	4.5	
	0.157	567	2.50		3.0
	0.158	567	2.50	4.6	
	0.161	579	2.55	4.7	
	0.162	583	2.57		3.1
	0.164	591	2.60	4.8	
	0.167	600	2.64		3.2
	0.168	603	2.66	4.9	
	0.171	615	2.71	5.0	
	0.171	616	2.71		3.3
	0.176	633	2.79		3.4
	0.180	649	2.86		3.5
	0.185	666	2.93		3.6
	0.189	682	3.00		3.7
	0.194	699	3.08		3.8
	0.199	715	3.15		3.9
	0.203	731	3.22		4.0
	0.208	748	3.29		4.1
	0.212	764	3.37		4.2
	0.217	781	3.44		4.3
	0.221	797	3.51		4.4
	0.226	814	3.58		4.5
	0.231	830	3.66		4.6
	0.235	847	3.73		4.7
	0.240	863	3.80		4.8
	0.244	880	3.87		4.9
	0.249	896	3.95		5.0

Accuracy: Greatest of either ±5% of controlled flow rate or ±2% of maximum flow rate

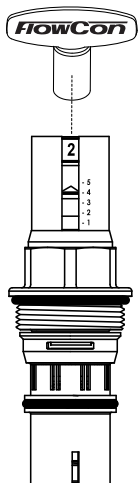

Use the FlowCon adjustment key (part number ACC0001) for adjusting the flow rate.

A setting of 4.2 corresponds to a flow rate of 0.212 l/sec for the 20mm green insert, range 35-400 kPaD.

## ACCESSORIES

- Blind cap: ACC0080 (cap without an insert for flushing out the system)
- Adjustment key: ACC0001 (key for adjusting the flow rate on E-JUST inserts).

## GENERAL SPECIFICATIONS

### 1. AUTOMATIC BALANCING VALVES - FLOWCON A

- 1.1. Contractor shall install automatic balancing valves where indicated in drawings.
- 1.2. Valve shall consist of dynamic, accessible, adjustable flow limiting device.

### 2. VALVE HOUSING

- 2.1. Valve housing shall consist of forged brass ASTM CuZn40Pb2, rated at no less than 2500 kPa static pressure and +120°C.
- 2.2. Valve housing shall be permanently marked to show direction of flow.
- 2.3. Housing shall be configured for flow regulation unit accessibility.

### 3.a. FLOW REGULATOR / AUTOMATIC BALANCING UNIT / COMPOSITE INSERT

- 3.a.1. Flow regulation unit assembly shall be manufactured of polyoxymethylene with a hydrogenated acrylonitrile-butadiene rubber or EPDM diaphragm and stainless steel 18-8 spring.
- 3.a.2. Flow regulation unit shall be readily accessible for change-out or maintenance.
- 3.a.3. Flow regulation unit shall be adjustable to 1 of 8 different flow rates and shall be available in 2 different kPaD operational ranges; minimum range shall be capable of being activated by minimum 15 kPaD. Further, the flow regulation unit shall be capable of controlling the flow within  $\pm 10\%$  of rated flow rate or 20l/hr.
- 3.a.4. Identification tags shall be available for all valves; tags shall be indelibly marked with flow rate, color and dial setting.

OR...

### 3.b. FLOW REGULATOR / AUTOMATIC BALANCING UNIT / E-JUST INSERT

- 3.b.1. Flow regulation unit assembly shall be manufactured of polysulfone with a hydrogenated acrylonitrile-butadiene rubber or EPDM diaphragm and stainless steel 18-8 spring.
- 3.b.2. Flow regulation unit shall be readily accessible for change-out or maintenance.
- 3.b.3. Flow regulation unit shall be adjustable with the valve in-line and the system in operation.
- 3.b.4. Flow regulation unit shall be externally adjustable to 1 of 41 different flow rates; shall be available in 4 different kPaD operational ranges for minimum range shall be capable of being activated by minimum 17 kPaD. Further, the flow regulation unit shall be capable of controlling flow within  $\pm 5\%$  of rated flow or  $\pm 2\%$  of maximum flow.
- 3.b.5. Identification tags shall be available for all valves; tags shall be indelibly marked with flow rate, color and dial setting.

## APPLICATION AND SCHEMATIC EXAMPLE

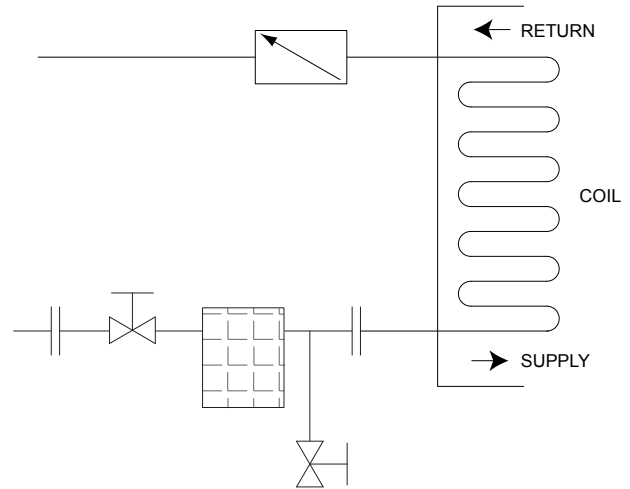
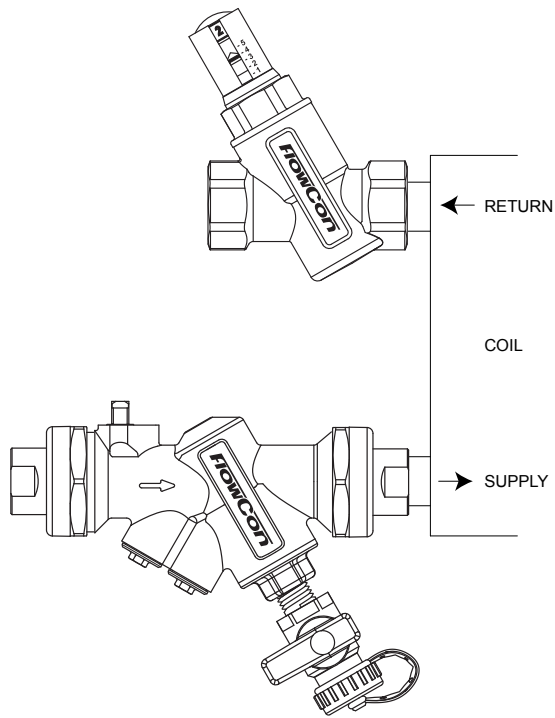

## UPDATES

**For latest updates please see [www.flowcon.com](http://www.flowcon.com)**

FlowCon International can accept no responsibility for possible errors in any printed material. All rights reserved.

# FlowCon AB 15-50mm

## *Dynamic Balancing Valve - Adjustable Insert*



### SPECIFICATIONS

Pressure rating:	2500 kPa / 360 psi
Temperature rating, media:	-20°C to +120°C / -4°F to +248°F
Material:	
- Insert:	Composite inserts: POM (Polyoxymethylene) E-JUST inserts: PSU (Polysulfone)
- Diaphragm:	Hydrogenated acrylonitrile-butadiene-rubber or EPDM depending on type
- Body:	Forged brass ASTM CuZn40Pb2
- O-rings:	EPDM
End connections:	Fixed female ISO or NPT
Body tappings:	1/4" ISO
Flow rate range:	0.0081-1.43 l/sec (standard composite insert) 0.0278-4.48 l/sec (E-JUST insert)



## FLOW RATE SETTING - COMPOSITE INSERT - FOR VALVES DN15-DN25 SMALL

20mm · 3/4" · composite insert · Y-type								
Pressure range, ΔP: 20-130 kPaD (15-130 kPaD)* · 2.9-18.9 psid (2.2-18.9 psid)*								
Nominal flow rate	Model no.			ABV1.Y.Y	ABV1.Y.R	ABV1.Y.U	ABV1.Y.B	ABV1.Y.G
	l/sec	l/hr	GPM	Grey*	Red	Blue	Black	Green
	0.0081	29.2	0.128	1				
	0.0133	47.9	0.211	2				
	0.0175	63.0	0.277	3				
	0.0222	79.9	0.352	4				
	0.0311	112	0.493	5				
	0.0353	127	0.560	6				
	0.0383	138	0.607	7				
	0.0431	155	0.683	8				
	0.0450	162	0.713				3	
	0.0575	207	0.911		4			
	0.0619	223	0.981			4		
	0.0669	241	1.06				4	
	0.0922	332	1.46		5			
	0.0978	352	1.55					1
	0.105	378	1.66		6			
	0.114	409	1.80		7			
	0.115	415	1.83			5		
	0.118	426	1.88					2
	0.119	430	1.89		8			
	0.136	489	2.15					3
	0.137	492	2.17			6		
	0.138	498	2.19					4
	0.146	524	2.31			7		
	0.146	526	2.32			8		
	0.155	557	2.45				5	
	0.176	635	2.80				6	
	0.180	647	2.85				7	
	0.193	695	3.06				8	
	0.231	830	3.66					5
	0.237	854	3.76					6
	0.253	909	4.00					7
	0.273	984	4.33					8

Accuracy: Greatest of either ±10% of controlled flow rate or 20 l/hr (0.0056 l/sec or 0.088 GPM).

20mm · 3/4" · composite insert · G-type								
Pressure range, ΔP: 40-400 kPaD (30-400 kPaD)* · 5.8-58 psid (4.4-58 psid)*								
Nominal flow rate	Model no.			ABV1.G.Y	ABV1.G.R	ABV1.G.U	ABV1.G.B	ABV1.G.G
	l/sec	l/hr	GPM	Grey*	Red	Blue	Black	Green
	0.0117	42.1	0.185	1				
	0.0189	68.0	0.300	2				
	0.0247	88.9	0.392	3				
	0.0325	117	0.515	4				
	0.0472	170	0.748	5				
	0.0528	190	0.837	6				
	0.0564	203	0.894			3		
	0.0597	215	0.946				3	
	0.0639	230	1.01	7				
	0.0694	250	1.10	8				
	0.0781	281	1.24		4			
	0.0908	327	1.44			4		
	0.0958	345	1.52				4	
	0.137	493	2.17		5			
	0.147	529	2.33					1
	0.161	581	2.56		6			
	0.173	624	2.75		7			
	0.181	652	2.87			5		
	0.181	653	2.88		8			
	0.186	670	2.95					2
	0.210	755	3.32					3
	0.216	779	3.43			6		
	0.218	785	3.46			7		
	0.220	792	3.49			8		
	0.237	853	3.75				5	
	0.241	869	3.83					4
	0.266	957	4.21				6	
	0.269	968	4.26				7	
	0.277	998	4.39				8	
	0.365	1320	5.79					5
	0.369	1330	5.85					6
	0.392	1410	6.21					7
	0.408	1470	6.46					8

Accuracy: Greatest of either ±10% of controlled flow rate or 20 l/hr (0.0056 l/sec or 0.088 GPM).



## FLOW RATE SETTING - COMPOSITE INSERT - FOR VALVES DN25 LARGE AND DN32

40mm · 1 1/2" · composite insert · X-type					
Pressure range, ΔP: 15-130 kPaD · 2.2-18.9 psid					
		Model no.		ABV2.X.W	ABV2.X.R
Nominal flow rate	I/sec	I/hr	GPM	White	Red
	0.17	612	2.69	1	
	0.23	828	3.64	2	
	0.26	936	4.12		1
	0.33	1190	5.23	3	
	0.38	1370	6.02	4	
	0.39	1400	6.18		2
	0.48	1730	7.61	5	3
	0.54	1940	8.56	6	
	0.62	2230	9.83	7	
	0.63	2270	9.99		4
	0.66	2380	10.5	8	
	0.67	2410	10.6		5
	0.76	2740	12.0		6
	0.85	3060	13.5		7



Accuracy: Greatest of either ±10% of controlled flow rate or 20 l/hr (0.0056 l/sec or 0.088 GPM).

40mm · 1 1/2" · composite insert · C-type					
Pressure range, ΔP: 22-300 kPaD · 3.2-43.5 psid					
		Model no.		ABV2.C.W	ABV2.C.R
Nominal flow rate	I/sec	I/hr	GPM	White	Red
	0.23	828	3.65	1	
	0.31	1120	4.91	2	
	0.38	1370	6.02		1
	0.42	1510	6.66	3	
	0.47	1690	7.45	4	
	0.50	1800	7.93		2
	0.60	2160	9.51	5	
	0.64	2300	10.1		3
	0.68	2450	10.8	6	
	0.78	2810	12.4	7	
	0.83	2990	13.2		4
	0.84	3020	13.3	8	
	0.90	3240	14.3		5
	1.07	3850	17.0		6
	1.17	4210	18.5		7
	1.21	4360	19.2		8

Accuracy: Greatest of either ±10% of controlled flow rate or 20 l/hr (0.0056 l/sec or 0.088 GPM).

40mm · 1 1/2" · composite insert · D-type					
Pressure range, ΔP: 30-410 kPaD · 4.4-59.5 psid					
		Model no.		ABV2.D.W	ABV2.D.R
Nominal flow rate	I/sec	I/hr	GPM	White	Red
	0.27	972	4.28	1	
	0.36	1300	5.71	2	
	0.44	1580	6.97		1
	0.52	1870	8.24	3	
	0.58	2090	9.19	4	
	0.60	2160	9.51		2
	0.74	2660	11.7	5	
	0.76	2740	12.0		3
	0.83	2990	13.2	6	
	0.93	3350	14.7	7	
	0.99	3560	15.7	8	4
	1.07	3850	17.0		5
	1.28	4610	20.3		6
	1.39	5000	22.0		7
1.43	5150	22.7		8	

Accuracy: Greatest of either ±10% of controlled flow rate or 20 l/hr (0.0056 l/sec or 0.088 GPM).

## FLOW RATE SETTING - E-JUST INSERT - FOR VALVES DN15-DN25 SMALL

20mm · 3/4" · E-JUST · Y-type · White pawl					
Pressure range, ΔP: 17-210 kPaD · 2.5-30 psid					
Nominal flow rate	Model no.			E-JUST1.Y.B	E-JUST1.Y.G
	l/sec	l/hr	GPM	Black	Green
				Setting	Setting
	0.0278	100	0.440	1.0	
	0.0299	108	0.475	1.1	
	0.0321	116	0.509	1.2	
	0.0343	123	0.543	1.3	
	0.0364	131	0.578	1.4	
	0.0386	139	0.612	1.5	
	0.0408	147	0.646	1.6	
	0.0429	155	0.681	1.7	
	0.0436	157	0.691		1.0
	0.0451	162	0.715	1.8	
	0.0468	168	0.741		1.1
	0.0473	170	0.749	1.9	
	0.0494	178	0.784	2.0	
	0.0499	180	0.791		1.2
	0.0516	186	0.818	2.1	
	0.0530	191	0.841		1.3
	0.0538	194	0.852	2.2	
	0.0559	201	0.887	2.3	
	0.0562	202	0.890		1.4
	0.0581	209	0.921	2.4	
	0.0593	214	0.940		1.5
	0.0603	217	0.955	2.5	
	0.0624	225	0.990	2.6	1.6
	0.0646	233	1.02	2.7	
	0.0656	236	1.04		1.7
	0.0668	240	1.06	2.8	
	0.0687	247	1.09		1.8
	0.0689	248	1.09	2.9	
	0.0711	256	1.13	3.0	
	0.0719	259	1.14		1.9
	0.0733	264	1.16	3.1	
	0.0750	270	1.19		2.0
	0.0754	272	1.20	3.2	
	0.0776	279	1.23	3.3	
	0.0781	281	1.24		2.1
	0.0798	287	1.26	3.4	
	0.0813	293	1.29		2.2
	0.0819	295	1.30	3.5	
	0.0841	303	1.33	3.6	
	0.0844	304	1.34		2.3
	0.0863	311	1.37	3.7	
	0.0876	315	1.39		2.4
	0.0884	318	1.40	3.8	

Continue next column...

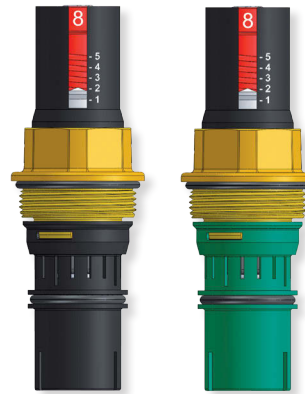

20mm · 3/4" · E-JUST · Y-type · White pawl					
Pressure range, ΔP: 17-210 kPaD · 2.5-30 psid					
Nominal flow rate	Model no.			E-JUST1.Y.B	E-JUST1.Y.G
	l/sec	l/hr	GPM	Black	Green
				Setting	Setting
	0.0906	326	1.44	3.9	
	0.0907	327	1.44		2.5
	0.0928	334	1.47	4.0	
	0.0938	338	1.49		2.6
	0.0949	342	1.50	4.1	
	0.0970	349	1.54		2.7
	0.0971	350	1.54	4.2	
	0.0993	357	1.57	4.3	
	0.100	360	1.59		2.8
	0.101	365	1.61	4.4	
	0.103	372	1.64		2.9
	0.104	373	1.64	4.5	
	0.106	381	1.68	4.6	
	0.106	383	1.69		3.0
	0.108	389	1.71	4.7	
	0.110	394	1.74		3.1
	0.110	396	1.75	4.8	
	0.112	404	1.78	4.9	
	0.113	406	1.79		3.2
	0.114	412	1.81	5.0	
	0.116	417	1.84		3.3
	0.119	428	1.89		3.4
	0.122	440	1.94		3.5
	0.125	451	1.98		3.6
	0.128	462	2.03		3.7
	0.132	473	2.08		3.8
	0.135	485	2.13		3.9
	0.138	496	2.18		4.0
	0.141	507	2.23		4.1
	0.144	519	2.28		4.2
	0.147	530	2.33		4.3
	0.150	541	2.38		4.4
	0.153	553	2.43		4.5
	0.157	564	2.48		4.6
	0.160	575	2.53		4.7
	0.163	586	2.58		4.8
	0.166	598	2.63		4.9
	0.169	609	2.68		5.0

Accuracy: Greatest of either ±5% of controlled flow rate or ±2% of maximum flow rate

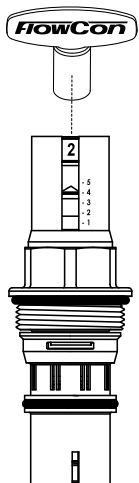

Use the FlowCon adjustment key (part number ACC0001) for adjusting the flow rate.

A setting of 4.2 corresponds to a flow rate of 0.144 l/sec for the 20mm green insert, range 17-210 kPaD.

## FLOW RATE SETTING - E-JUST INSERT - FOR VALVES DN15-DN25 SMALL (continued)

20mm · 3/4" · E-JUST · Y-type · White pawl				
Pressure range. ΔP: 17-200 kPaD · 2.5-29 psid				
Nominal flow rate	Model no.			E-JUST1.Y.R
	l/sec	l/hr	GPM	Red
				Setting
	0.0767	276	1.22	1.0
	0.0813	293	1.29	1.1
	0.0860	310	1.36	1.2
	0.0907	326	1.44	1.3
	0.0953	343	1.51	1.4
	0.100	360	1.58	1.5
	0.105	377	1.66	1.6
	0.109	393	1.73	1.7
	0.114	410	1.80	1.8
	0.118	426	1.88	1.9
	0.123	443	1.95	2.0
	0.128	459	2.02	2.1
	0.132	475	2.09	2.2
	0.136	491	2.16	2.3
	0.141	507	2.23	2.4
	0.145	523	2.30	2.5
	0.150	539	2.37	2.6
	0.154	554	2.44	2.7
	0.158	569	2.51	2.8
	0.162	584	2.57	2.9
	0.166	599	2.64	3.0
	0.170	614	2.70	3.1
	0.174	628	2.76	3.2
	0.178	642	2.83	3.3
	0.182	655	2.89	3.4
	0.186	669	2.94	3.5
	0.189	682	3.00	3.6
	0.193	695	3.06	3.7
	0.196	707	3.11	3.8
	0.200	719	3.17	3.9
	0.203	731	3.22	4.0
	0.206	742	3.27	4.1
	0.209	753	3.32	4.2
	0.212	764	3.36	4.3
	0.215	774	3.41	4.4
	0.218	784	3.45	4.5
	0.220	793	3.49	4.6
	0.223	802	3.53	4.7
	0.225	810	3.57	4.8
	0.227	818	3.60	4.9
	0.229	825	3.60	5.0

Accuracy: Greatest of either ±5% of controlled flow rate or ±2% of maximum flow rate

20mm · 3/4" · E-JUST · G-type · Grey pawl				
Pressure range. ΔP: 30-400 kPaD · 4.4-58 psid				
Nominal flow rate	Model no.			E-JUST1.G.R
	l/sec	l/hr	GPM	Red
				Setting
	0.113	406	1.79	1.0
	0.119	427	1.88	1.1
	0.125	449	1.98	1.2
	0.131	470	2.07	1.3
	0.137	492	2.17	1.4
	0.143	513	2.26	1.5
	0.149	535	2.36	1.6
	0.155	556	2.45	1.7
	0.161	578	2.54	1.8
	0.167	599	2.64	1.9
	0.172	621	2.73	2.0
	0.178	642	2.83	2.1
	0.184	664	2.92	2.2
	0.190	685	3.02	2.3
	0.196	707	3.11	2.4
	0.202	728	3.21	2.5
	0.208	750	3.30	2.6
	0.214	771	3.40	2.7
	0.220	793	3.49	2.8
	0.226	814	3.59	2.9
	0.232	836	3.68	3.0
	0.238	857	3.78	3.1
	0.244	879	3.87	3.2
	0.250	900	3.96	3.3
	0.256	922	4.06	3.4
	0.262	943	4.15	3.5
	0.268	965	4.25	3.6
	0.274	987	4.34	3.7
	0.280	1010	4.44	3.8
	0.286	1030	4.53	3.9
	0.292	1050	4.63	4.0
	0.298	1070	4.72	4.1
	0.304	1090	4.82	4.2
	0.310	1120	4.91	4.3
	0.316	1140	5.01	4.4
	0.322	1160	5.10	4.5
	0.328	1180	5.20	4.6
	0.334	1200	5.29	4.7
	0.340	1220	5.38	4.8
	0.346	1240	5.48	4.9
	0.352	1270	5.57	5.0

Accuracy: Greatest of either ±5% of controlled flow rate or ±2% of maximum flow rate

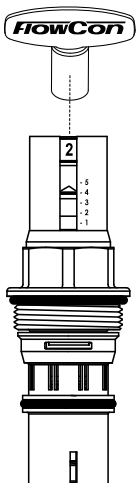
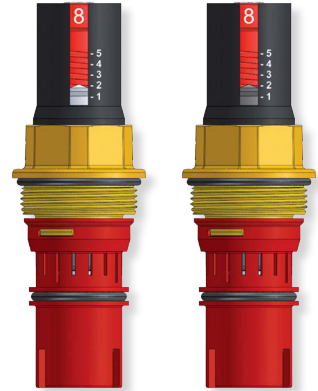

Use the FlowCon adjustment key (part number ACC0001) for adjusting the flow rate.

A setting of 4.2 corresponds to a flow rate of 0.304 l/sec for the 20mm red insert, range 30-400 kPaD.

**FLOW RATE SETTING - E-JUST INSERT - FOR VALVES DN15-DN25 SMALL (continued)**

20mm · 3/4" · E-JUST · G-type · Grey pawl					
Pressure range, ΔP: 35-400 kPaD · 5.1-58 psid					
Nominal flow rate	Model no.			E-JUST1.G.B	E-JUST1.G.G
	l/sec	l/hr	GPM	Black	Green
				Setting	Setting
	0.0383	138	0.607	1.0	
	0.0416	150	0.660	1.1	
	0.0449	162	0.712	1.2	
	0.0483	174	0.765	1.3	
	0.0516	186	0.817	1.4	
	0.0549	198	0.870	1.5	
	0.0582	210	0.922	1.6	
	0.0615	221	0.975	1.7	
	0.0648	233	1.03	1.8	
	0.0660	238	1.05		1.0
	0.0681	245	1.08	1.9	
	0.0706	254	1.12		1.1
	0.0714	257	1.13	2.0	
	0.0748	269	1.18	2.1	
	0.0751	271	1.19		1.2
	0.0781	281	1.24	2.2	
	0.0797	287	1.26		1.3
	0.0814	293	1.29	2.3	
	0.0843	304	1.34		1.4
	0.0847	305	1.34	2.4	
	0.0880	317	1.40	2.5	
	0.0889	320	1.41		1.5
	0.0913	329	1.45	2.6	
	0.0934	336	1.48		1.6
	0.0946	341	1.50	2.7	
	0.0979	353	1.55	2.8	
	0.0980	353	1.55		1.7
	0.101	365	1.61	2.9	
	0.103	369	1.63		1.8
	0.105	377	1.66	3.0	
	0.107	386	1.70		1.9
	0.108	388	1.71	3.1	
	0.111	400	1.76	3.2	
	0.112	402	1.77		2.0
	0.115	412	1.82	3.3	
	0.116	419	1.84		2.1
	0.118	424	1.87	3.4	
	0.121	435	1.92		2.2
	0.121	436	1.92	3.5	
	0.124	448	1.97	3.6	
	0.125	452	1.99		2.3
	0.128	460	2.03	3.7	
	0.130	468	2.06		2.4
	0.131	472	2.08	3.8	

Continue next column...

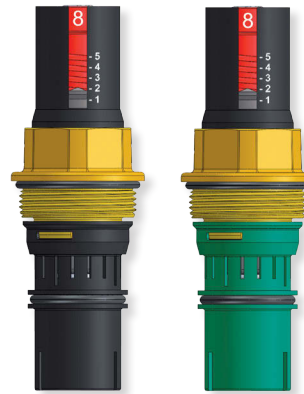

20mm · 3/4" · E-JUST · G-type · Grey pawl					
Pressure range, ΔP: 35-400 kPaD · 5.1-58 psid					
Nominal flow rate	Model no.			E-JUST1.G.B	E-JUST1.G.G
	l/sec	l/hr	GPM	Black	Green
				Setting	Setting
	0.134	484	2.13	3.9	
	0.135	485	2.13		2.5
	0.138	496	2.18	4.0	
	0.139	501	2.21		2.6
	0.141	508	2.24	4.1	
	0.144	517	2.28		2.7
	0.144	520	2.29	4.2	
	0.148	532	2.34	4.3	
	0.148	534	2.35		2.8
	0.151	544	2.39	4.4	
	0.153	550	2.42		2.9
	0.154	556	2.45	4.5	
	0.157	567	2.50		3.0
	0.158	567	2.50	4.6	
	0.161	579	2.55	4.7	
	0.162	583	2.57		3.1
	0.164	591	2.60	4.8	
	0.167	600	2.64		3.2
	0.168	603	2.66	4.9	
	0.171	615	2.71	5.0	
	0.171	616	2.71		3.3
	0.176	633	2.79		3.4
	0.180	649	2.86		3.5
	0.185	666	2.93		3.6
	0.189	682	3.00		3.7
	0.194	699	3.08		3.8
	0.199	715	3.15		3.9
	0.203	731	3.22		4.0
	0.208	748	3.29		4.1
	0.212	764	3.37		4.2
	0.217	781	3.44		4.3
	0.221	797	3.51		4.4
	0.226	814	3.58		4.5
	0.231	830	3.66		4.6
	0.235	847	3.73		4.7
	0.240	863	3.80		4.8
	0.244	880	3.87		4.9
	0.249	896	3.95		5.0

Accuracy: Greatest of either ±5% of controlled flow rate or ±2% of maximum flow rate

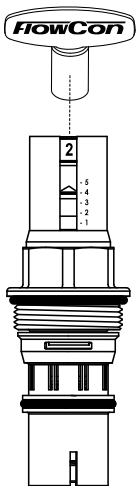

Use the FlowCon adjustment key (part number ACC0001) for adjusting the flow rate.

A setting of 4.2 corresponds to a flow rate of 0.212 l/sec for the 20mm green insert, range 35-400 kPaD.

## FLOW RATE SETTING - E-JUST INSERT - FOR VALVES DN25 LARGE AND DN32

40mm · 1 1/2" · E-JUST · Y-type · White pawl				
Pressure range. ΔP: 17-400 kPaD · 2.5-58 psid				
Model no. E-JUST2.Y.G				
Nominal flow rate	l/sec	l/hr	GPM	Setting
	0.149	535	2.36	1.0
	0.220	793	3.49	1.1
	0.289	1040	4.58	1.2
	0.355	1280	5.63	1.3
	0.418	1510	6.63	1.4
	0.479	1730	7.60	1.5
	0.538	1940	8.52	1.6
	0.594	2140	9.41	1.7
	0.647	2330	10.3	1.8
	0.699	2520	11.1	1.9
	0.748	2690	11.9	2.0
	0.795	2860	12.6	2.1
	0.841	3030	13.3	2.2
	0.884	3180	14.0	2.3
	0.925	3330	14.7	2.4
	0.965	3470	15.3	2.5
	1.00	3610	15.9	2.6
	1.04	3740	16.5	2.7
	1.07	3870	17.0	2.8
	1.11	3990	17.6	2.9
	1.14	4100	18.1	3.0
	1.17	4220	18.6	3.1
	1.20	4320	19.0	3.2
1.23	4420	19.5	3.3	
1.26	4520	19.9	3.4	
1.28	4620	20.3	3.5	
1.31	4710	20.7	3.6	
1.33	4800	21.1	3.7	
1.36	4890	21.5	3.8	
1.38	4970	21.9	3.9	
1.40	5050	22.3	4.0	
1.43	5130	22.6	4.1	
1.45	5210	23.0	4.2	
1.47	5290	23.3	4.3	
1.49	5370	23.6	4.4	
1.51	5440	24.0	4.5	
1.53	5520	24.3	4.6	
1.55	5600	24.6	4.7	
1.58	5670	25.0	4.8	
1.60	5750	25.3	4.9	
1.62	5830	25.7	5.0	

Accuracy: Greatest of either ±5% of controlled flow rate or ±2% of maximum flow rate

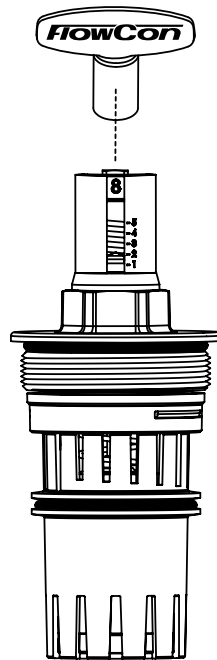
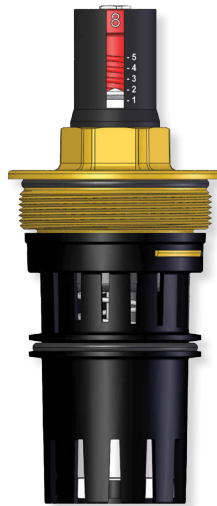

Use the FlowCon adjustment key (part number ACC0001) for adjusting the flow rate.

A setting of 4.2 corresponds to a flow rate of 1.45 l/sec for the 40mm insert, range 17-400 kPaD.

## FLOW RATE SETTING - E-JUST INSERT - FOR VALVES DN40 AND DN50

50mm · 2" · E-JUST · G-type · Grey pawl				
Pressure range. ΔP: 20-400 kPaD · 2.9-58 psid				
Model no. E-JUST3.G.B				
Nominal flow rate	l/sec	l/hr	GPM	Setting
	0.883	3180	14.0	1.0
	1.14	4100	18.0	1.1
	1.37	4940	21.7	1.2
	1.59	5710	25.1	1.3
	1.78	6420	28.3	1.4
	1.96	7070	31.1	1.5
	2.13	7660	33.7	1.6
	2.28	8200	36.1	1.7
	2.42	8700	38.3	1.8
	2.54	9150	40.3	1.9
	2.66	9570	42.1	2.0
	2.77	9960	43.8	2.1
	2.86	10300	45.4	2.2
	2.95	10600	46.8	2.3
	3.04	10900	48.2	2.4
	3.12	11200	49.4	2.5
	3.19	11500	50.6	2.6
	3.26	11700	51.7	2.7
	3.32	12000	52.7	2.8
	3.39	12200	53.7	2.9
	3.45	12400	54.6	3.0
	3.51	12600	55.6	3.1
	3.56	12800	56.5	3.2
	3.62	13000	57.3	3.3
	3.67	13200	58.2	3.4
3.73	13400	59.1	3.5	
3.78	13600	59.9	3.6	
3.83	13800	60.8	3.7	
3.89	14000	61.6	3.8	
3.94	14200	62.4	3.9	
3.99	14400	63.3	4.0	
4.05	14600	64.1	4.1	
4.10	14800	65.0	4.2	
4.15	14900	65.8	4.3	
4.20	15100	66.6	4.4	
4.25	15300	67.4	4.5	
4.30	15500	68.2	4.6	
4.35	15700	68.9	4.7	
4.39	15800	69.6	4.8	
4.44	16000	70.3	4.9	
4.48	16100	70.9	5.0	

Accuracy: Greatest of either ±5% of controlled flow rate or ±2% of maximum flow rate

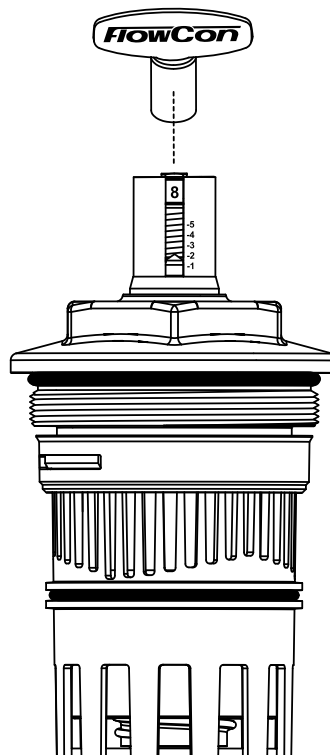
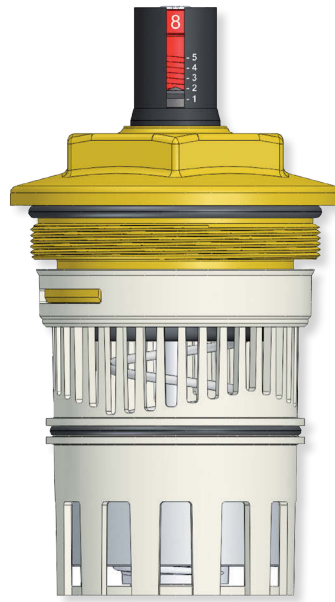

Use the FlowCon adjustment key (part number ACC0001) for adjusting the flow rate.

A setting of 4.2 corresponds to a flow rate of 4.10 l/sec for the 50mm insert, range 20-400 kPaD.

## ACCESSORIES

- P/t plugs: 2 x ACC00101
- Blind cap: ACC0080 / ACC0081 / ACC0084 (cap (small / medium / large) without an insert for flushing out the system)
- Adjustment key: ACC0001 (key for adjusting the flow rate on E-JUST inserts).

## GENERAL SPECIFICATIONS

### 1. AUTOMATIC BALANCING VALVES - FLOWCON AB

- 1.1. Contractor shall install automatic balancing valves where indicated in drawings.
- 1.2. Valve shall consist of dynamic, accessible, adjustable flow limiting device.

### 2. VALVE HOUSING

- 2.1. Valve housing shall consist of forged brass ASTM CuZn40Pb2, rated at no less than 2500 kPa static pressure and +120°C.
- 2.2. Valve housing shall be permanently marked to show direction of flow.
- 2.3. Optional dual pressure/temperature test plugs for verifying accuracy of flow performance shall be available for all valve sizes.
- 2.4. Housing shall be configured for flow regulation unit accessibility.

### 3.a. FLOW REGULATOR / AUTOMATIC BALANCING UNIT / COMPOSITE INSERT

- 3.a.1. Flow regulation unit assembly shall be manufactured of polyoxymethylene with a hydrogenated acrylonitrile-butadiene rubber or EPDM diaphragm and stainless steel 18-8 spring.
- 3.a.2. Flow regulation unit shall be readily accessible for change-out or maintenance.
- 3.a.3. Flow regulation unit shall be adjustable to 1 of 8 different flow rates; shall be available in 2 different kPaD operational ranges for DN15/20/25 and 3 different kPaD operational ranges for DN25/32/40; minimum range shall be capable of being activated by minimum 15 kPaD. Further, the flow regulation unit shall be capable of controlling flow within  $\pm 10\%$  of rated flow rate or 20l/hr.
- 3.a.4. Identification tags shall be available for all valves; tags shall be indelibly marked with flow rate, color and dial setting.

OR...

### 3.b. FLOW REGULATOR / AUTOMATIC BALANCING UNIT / E-JUST INSERT

- 3.b.1. Flow regulation unit assembly shall be manufactured of polysulfone with a hydrogenated acrylonitrile-butadiene rubber or EPDM diaphragm and stainless steel 18-8 spring.
- 3.b.2. Flow regulation unit shall be readily accessible for change-out or maintenance.
- 3.b.3. Flow regulation unit shall be adjustable with the valve in-line and the system in operation.
- 3.b.4. Flow regulation unit shall be externally adjustable to 1 of 41 different flow rates; shall be available in 4 different kPaD operational ranges for DN15/20/25, 1 kPaD operational range for DN25/32/40 and 1 kPaD operational range for DN40/50; minimum range shall be capable of being activated by minimum 17 kPaD. Further, the flow regulation unit shall be capable of controlling flow within  $\pm 5\%$  of rated flow or  $\pm 2\%$  of maximum flow.
- 3.b.5. Identification tags shall be available for all valves; tags shall be indelibly marked with flow rate, colour and dial setting.

## APPLICATION AND SCHEMATIC EXAMPLE

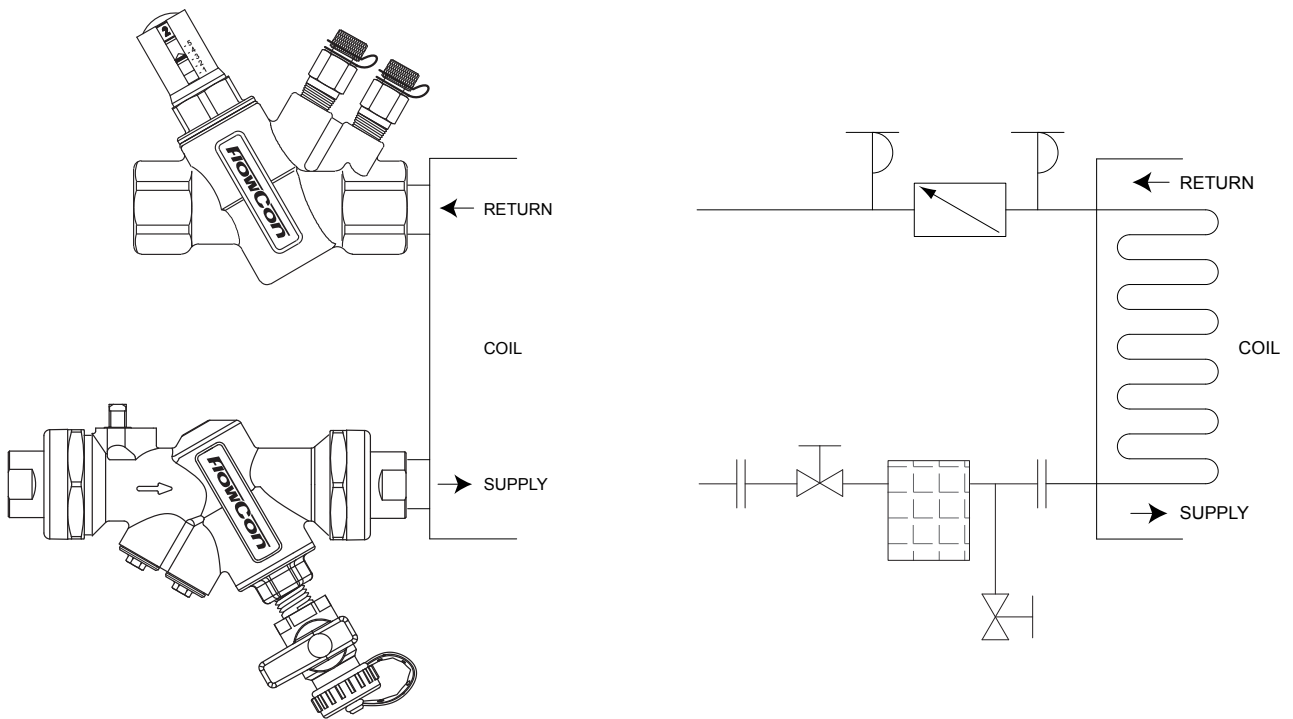

## UPDATES

**For latest updates please see [www.flowcon.com](http://www.flowcon.com)**

FlowCon International can accept no responsibility for possible errors in any printed material.  
All rights reserved.

# FlowCon ABV 15-40mm

## *Dynamic Balancing Valve - Adjustable Insert*



### SPECIFICATIONS

Pressure rating:	2500 kPa / 360 psi
Temperature rating, media:	-20°C to +120°C / -4°F to +248°F
Material:	
- Insert:	Composite inserts: POM (Polyoxymethylene) E-JUST inserts: PSU (Polysulfone)
- Diaphragm:	Hydrogenated acrylonitrile-butadiene-rubber or EPDM depending on type
- Body:	Forged brass ASTM CuZn40Pb2
- Ball valve:	Chemically nickel plated brass ball
- Union end connections:	Brass alloy ISO or NPT
- O-rings:	EPDM
Body tappings:	1/4" ISO
Flow rate range:	0.0081-1.43 l/sec (standard composite insert) 0.0278-1.62 l/sec (E-JUST insert)

## DIMENSIONS AND WEIGHTS (NOMINAL) (measured in mm unless noted)

Model no.	Valve size	Insert size	L	H1	H2	H3	End connections C <sup>1</sup>			Weight (kgs.) w/o end conn.	Kv <sup>2</sup> (m <sup>3</sup> /hr)
							ISO female	ISO male	Sweat		
ABV1	15	20	122	66	33	78	22	24	20	0.8	3.1
	20						22	25	20		
	25						-	39	22		
ABV2	25	40	162	75	42	99	35	40	34	2.5	11.7
	32						33	40	34		
	40						33	42	-		

Note 1: Add end connection length to body length.  
 Note 2: For valve body.

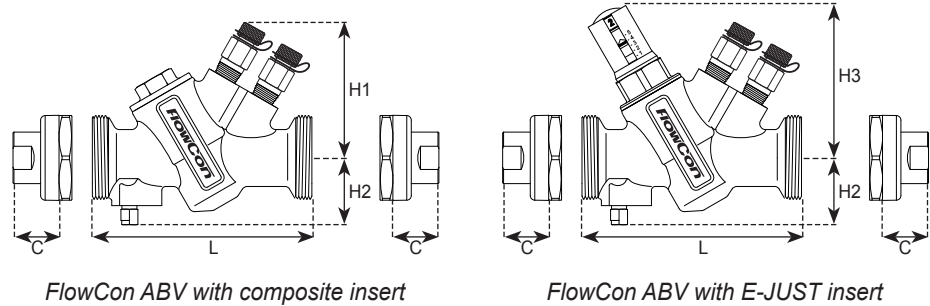

FlowCon ABV with composite insert

FlowCon ABV with E-JUST insert

## MODEL NUMBER SELECTION<sup>3</sup>

**ABV**

Insert body size:  
**1**=ABV1 (union end 15/20/25mm)    **2**=ABV2 (union end 25/32/40mm)

Leave it **blank** if taps open    **B**=pressure temperature plugs    **P**=taps plugged

Insert inlet x outlet union end connections:

Body size	Female threaded	Male treaded	Sweat
Union end 15-20mm, 1/2"-1" with 20mm composite insert or 20mm E-JUST insert	<b>E</b> =15mm=1/2" <b>F</b> =20mm=3/4"	<b>H</b> =15mm=1/2" <b>I</b> =20mm=3/4" <b>J</b> =25mm=1"	<b>K</b> =15mm <b>L</b> =18mm <b>M</b> =22mm
Union end 25-40mm, 1"-1 1/2" with 40mm composite insert or 40mm E-JUST insert	<b>G</b> =25mm=1" <b>P</b> =32mm=1 1/4" <b>Q</b> =40mm=1 1/2"	<b>J</b> =25mm=1" <b>S</b> =32mm=1 1/4" <b>T</b> =40mm=1 1/2"	<b>N</b> =28mm <b>W</b> =35mm

Insert connection standard:  
**I**=ISO    **N**=NPT

Insert a kPaD control range:  
**0** if no insert required  
**Y** = 15-130 kPaD (20mm standard composite insert)  
 17-200 kPaD (20mm E-JUST red - white pawl)  
 17-210 kPaD (20mm E-JUST black or green - white pawl)  
 17-400 kPaD (40mm E-JUST - white pawl)  
**G** = 30-400 kPaD (20mm standard composite insert)  
 30-400 kPaD (20mm E-JUST red - grey pawl)  
 35-400 kPaD (20mm E-JUST black or green - grey pawl)  
**X** = 15-130 kPaD (40mm standard composite insert)  
**C** = 22-300 kPaD (40mm standard composite insert)  
**D** = 30-410 kPaD (40mm standard composite insert)  
 (Determine from insert selection chart)

Insert automatic flow limiting insert code:  
**0** if no insert required    **Y**=grey    **R**=red    **U**=blue    **B**=black    **G**=green    **W**=white  
 (Determine from insert selection chart)

Insert insert dial setting/type:  
**1 to 8**=dial setting on standard composite insert  
**0**=standard pre-setting of 2 on standard composite insert  
**E**=E-JUST insert  
 (Determine from insert selection chart)

Example: ABV1.B.E.E.I.Y.B.E=ABV1-body with p/t plugs, 15mm ISO female threaded union end connections with a Y-type black E-JUST insert.

Note 3: Flow rate, color and dial setting of insert are indicated on label affixed to body.

## FLOW RATE SETTING - COMPOSITE INSERT - FOR VALVES DN15-DN25 SMALL

20mm · 3/4" · composite insert · Y-type								
Pressure range, ΔP: 20-130 kPaD (15-130 kPaD)* · 2.9-18.9 psid (2.2-18.9 psid)*								
Nominal flow rate	Model no.			ABV1.Y.Y	ABV1.Y.R	ABV1.Y.U	ABV1.Y.B	ABV1.Y.G
	l/sec	l/hr	GPM	Grey*	Red	Blue	Black	Green
	0.0081	29.2	0.128	1				
	0.0133	47.9	0.211	2				
	0.0175	63.0	0.277	3				
	0.0222	79.9	0.352	4				
	0.0311	112	0.493	5				
	0.0353	127	0.560	6				
	0.0383	138	0.607	7				
	0.0431	155	0.683	8				
	0.0450	162	0.713				3	
	0.0575	207	0.911		4			
	0.0619	223	0.981			4		
	0.0669	241	1.06				4	
	0.0922	332	1.46		5			
	0.0978	352	1.55					1
	0.105	378	1.66		6			
	0.114	409	1.80		7			
	0.115	415	1.83			5		
	0.118	426	1.88					2
	0.119	430	1.89		8			
	0.136	489	2.15					3
	0.137	492	2.17			6		
	0.138	498	2.19					4
	0.146	524	2.31			7		
	0.146	526	2.32			8		
	0.155	557	2.45				5	
	0.176	635	2.80				6	
	0.180	647	2.85				7	
	0.193	695	3.06				8	
	0.231	830	3.66					5
	0.237	854	3.76					6
	0.253	909	4.00					7
	0.273	984	4.33					8

Accuracy: Greatest of either ±10% of controlled flow rate or 20 l/hr (0.0056 l/sec or 0.088 GPM).

20mm · 3/4" · composite insert · G-type								
Pressure range, ΔP: 40-400 kPaD (30-400 kPaD)* · 5.8-58 psid (4.4-58 psid)*								
Nominal flow rate	Model no.			ABV1.G.Y	ABV1.G.R	ABV1.G.U	ABV1.G.B	ABV1.G.G
	l/sec	l/hr	GPM	Grey*	Red	Blue	Black	Green
	0.0117	42.1	0.185	1				
	0.0189	68.0	0.300	2				
	0.0247	88.9	0.392	3				
	0.0325	117	0.515	4				
	0.0472	170	0.748	5				
	0.0528	190	0.837	6				
	0.0564	203	0.894			3		
	0.0597	215	0.946				3	
	0.0639	230	1.01	7				
	0.0694	250	1.10	8				
	0.0781	281	1.24		4			
	0.0908	327	1.44			4		
	0.0958	345	1.52				4	
	0.137	493	2.17		5			
	0.147	529	2.33					1
	0.161	581	2.56		6			
	0.173	624	2.75		7			
	0.181	652	2.87			5		
	0.181	653	2.88		8			
	0.186	670	2.95					2
	0.210	755	3.32					3
	0.216	779	3.43			6		
	0.218	785	3.46			7		
	0.220	792	3.49			8		
	0.237	853	3.75				5	
	0.241	869	3.83					4
	0.266	957	4.21				6	
	0.269	968	4.26				7	
	0.277	998	4.39				8	
	0.365	1320	5.79					5
	0.369	1330	5.85					6
	0.392	1410	6.21					7
	0.408	1470	6.46					8

Accuracy: Greatest of either ±10% of controlled flow rate or 20 l/hr (0.0056 l/sec or 0.088 GPM).



## FLOW RATE SETTING - COMPOSITE INSERT - FOR VALVES DN25 LARGE-DN40

40mm · 1 1/2" · composite insert · X-type					
Pressure range, ΔP: 15-130 kPaD · 2.2-18.9 psid					
Nominal flow rate	Model no.		ABV2.X.W	ABV2.X.R	
	I/sec	I/hr	GPM	White	Red
	0.17	612	2.69	1	
	0.23	828	3.64	2	
	0.26	936	4.12		1
	0.33	1190	5.23	3	
	0.38	1370	6.02	4	
	0.39	1400	6.18		2
	0.48	1730	7.61	5	3
	0.54	1940	8.56	6	
	0.62	2230	9.83	7	
	0.63	2270	9.99		4
0.66	2380	10.5	8		
0.67	2410	10.6		5	
0.76	2740	12.0		6	
0.85	3060	13.5		7	



Accuracy: Greatest of either ±10% of controlled flow rate or 20 l/hr (0.0056 l/sec or 0.088 GPM).

40mm · 1 1/2" · composite insert · C-type					
Pressure range, ΔP: 22-300 kPaD · 3.2-43.5 psid					
Nominal flow rate	Model no.		ABV2.C.W	ABV2.C.R	
	I/sec	I/hr	GPM	White	Red
	0.23	828	3.65	1	
	0.31	1120	4.91	2	
	0.38	1370	6.02		1
	0.42	1510	6.66	3	
	0.47	1690	7.45	4	
	0.50	1800	7.93		2
	0.60	2160	9.51	5	
	0.64	2300	10.1		3
	0.68	2450	10.8	6	
	0.78	2810	12.4	7	
	0.83	2990	13.2		4
	0.84	3020	13.3	8	
0.90	3240	14.3		5	
1.07	3850	17.0		6	
1.17	4210	18.5		7	
1.21	4360	19.2		8	

Accuracy: Greatest of either ±10% of controlled flow rate or 20 l/hr (0.0056 l/sec or 0.088 GPM).

40mm · 1 1/2" · composite insert · D-type					
Pressure range, ΔP: 30-410 kPaD · 4.4-59.5 psid					
Nominal flow rate	Model no.		ABV2.D.W	ABV2.D.R	
	I/sec	I/hr	GPM	White	Red
	0.27	972	4.28	1	
	0.36	1300	5.71	2	
	0.44	1580	6.97		1
	0.52	1870	8.24	3	
	0.58	2090	9.19	4	
	0.60	2160	9.51		2
	0.74	2660	11.7	5	
	0.76	2740	12.0		3
	0.83	2990	13.2	6	
	0.93	3350	14.7	7	
	0.99	3560	15.7	8	4
	1.07	3850	17.0		5
	1.28	4610	20.3		6
1.39	5000	22.0		7	
1.43	5150	22.7		8	

Accuracy: Greatest of either ±10% of controlled flow rate or 20 l/hr (0.0056 l/sec or 0.088 GPM).

## FLOW RATE SETTING - E-JUST INSERT - FOR VALVES DN15-DN25 SMALL

20mm · 3/4" · E-JUST · Y-type · White pawl					
Pressure range, ΔP: 17-210 kPaD · 2.5-30 psid					
Nominal flow rate	Model no.			E-JUST1.Y.B	E-JUST1.Y.G
	l/sec	l/hr	GPM	Black	Green
				Setting	Setting
	0.0278	100	0.440	1.0	
	0.0299	108	0.475	1.1	
	0.0321	116	0.509	1.2	
	0.0343	123	0.543	1.3	
	0.0364	131	0.578	1.4	
	0.0386	139	0.612	1.5	
	0.0408	147	0.646	1.6	
	0.0429	155	0.681	1.7	
	0.0436	157	0.691		1.0
	0.0451	162	0.715	1.8	
	0.0468	168	0.741		1.1
	0.0473	170	0.749	1.9	
	0.0494	178	0.784	2.0	
	0.0499	180	0.791		1.2
	0.0516	186	0.818	2.1	
	0.0530	191	0.841		1.3
	0.0538	194	0.852	2.2	
	0.0559	201	0.887	2.3	
	0.0562	202	0.890		1.4
	0.0581	209	0.921	2.4	
	0.0593	214	0.940		1.5
	0.0603	217	0.955	2.5	
	0.0624	225	0.990	2.6	1.6
	0.0646	233	1.02	2.7	
	0.0656	236	1.04		1.7
	0.0668	240	1.06	2.8	
	0.0687	247	1.09		1.8
	0.0689	248	1.09	2.9	
	0.0711	256	1.13	3.0	
	0.0719	259	1.14		1.9
	0.0733	264	1.16	3.1	
	0.0750	270	1.19		2.0
	0.0754	272	1.20	3.2	
	0.0776	279	1.23	3.3	
	0.0781	281	1.24		2.1
	0.0798	287	1.26	3.4	
	0.0813	293	1.29		2.2
	0.0819	295	1.30	3.5	
	0.0841	303	1.33	3.6	
	0.0844	304	1.34		2.3
	0.0863	311	1.37	3.7	
	0.0876	315	1.39		2.4
	0.0884	318	1.40	3.8	

Continue next column...

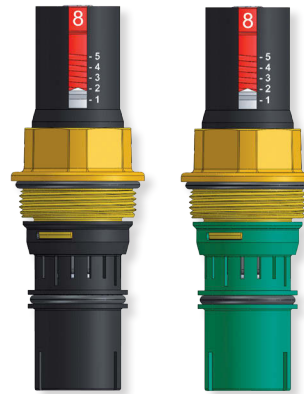

20mm · 3/4" · E-JUST · Y-type · White pawl					
Pressure range, ΔP: 17-210 kPaD · 2.5-30 psid					
Nominal flow rate	Model no.			E-JUST1.Y.B	E-JUST1.Y.G
	l/sec	l/hr	GPM	Black	Green
				Setting	Setting
	0.0906	326	1.44	3.9	
	0.0907	327	1.44		2.5
	0.0928	334	1.47	4.0	
	0.0938	338	1.49		2.6
	0.0949	342	1.50	4.1	
	0.0970	349	1.54		2.7
	0.0971	350	1.54	4.2	
	0.0993	357	1.57	4.3	
	0.100	360	1.59		2.8
	0.101	365	1.61	4.4	
	0.103	372	1.64		2.9
	0.104	373	1.64	4.5	
	0.106	381	1.68	4.6	
	0.106	383	1.69		3.0
	0.108	389	1.71	4.7	
	0.110	394	1.74		3.1
	0.110	396	1.75	4.8	
	0.112	404	1.78	4.9	
	0.113	406	1.79		3.2
	0.114	412	1.81	5.0	
	0.116	417	1.84		3.3
	0.119	428	1.89		3.4
	0.122	440	1.94		3.5
	0.125	451	1.98		3.6
	0.128	462	2.03		3.7
	0.132	473	2.08		3.8
	0.135	485	2.13		3.9
	0.138	496	2.18		4.0
	0.141	507	2.23		4.1
	0.144	519	2.28		4.2
	0.147	530	2.33		4.3
	0.150	541	2.38		4.4
	0.153	553	2.43		4.5
	0.157	564	2.48		4.6
	0.160	575	2.53		4.7
	0.163	586	2.58		4.8
	0.166	598	2.63		4.9
	0.169	609	2.68		5.0

Accuracy: Greatest of either ±5% of controlled flow rate or ±2% of maximum flow rate

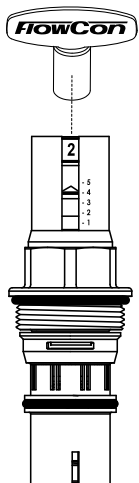

Use the FlowCon adjustment key (part number ACC0001) for adjusting the flow rate.

A setting of 4.2 corresponds to a flow rate of 0.144 l/sec for the 20mm green insert, range 17-210 kPaD.

## FLOW RATE SETTING - E-JUST INSERT - FOR VALVES DN15-DN25 SMALL (continued)

20mm · 3/4" · E-JUST · Y-type · White pawl				
Pressure range. ΔP: 17-200 kPaD · 2.5-29 psid				
	Model no.			E-JUST1.Y.R
	l/sec	l/hr	GPM	Red
				Setting
Nominal flow rate	0.0767	276	1.22	1.0
	0.0813	293	1.29	1.1
	0.0860	310	1.36	1.2
	0.0907	326	1.44	1.3
	0.0953	343	1.51	1.4
	0.100	360	1.58	1.5
	0.105	377	1.66	1.6
	0.109	393	1.73	1.7
	0.114	410	1.80	1.8
	0.118	426	1.88	1.9
	0.123	443	1.95	2.0
	0.128	459	2.02	2.1
	0.132	475	2.09	2.2
	0.136	491	2.16	2.3
	0.141	507	2.23	2.4
	0.145	523	2.30	2.5
	0.150	539	2.37	2.6
	0.154	554	2.44	2.7
	0.158	569	2.51	2.8
	0.162	584	2.57	2.9
	0.166	599	2.64	3.0
	0.170	614	2.70	3.1
	0.174	628	2.76	3.2
	0.178	642	2.83	3.3
	0.182	655	2.89	3.4
	0.186	669	2.94	3.5
	0.189	682	3.00	3.6
	0.193	695	3.06	3.7
	0.196	707	3.11	3.8
	0.200	719	3.17	3.9
0.203	731	3.22	4.0	
0.206	742	3.27	4.1	
0.209	753	3.32	4.2	
0.212	764	3.36	4.3	
0.215	774	3.41	4.4	
0.218	784	3.45	4.5	
0.220	793	3.49	4.6	
0.223	802	3.53	4.7	
0.225	810	3.57	4.8	
0.227	818	3.60	4.9	
0.229	825	3.60	5.0	

Accuracy: Greatest of either ±5% of controlled flow rate or ±2% of maximum flow rate

20mm · 3/4" · E-JUST · G-type · Grey pawl				
Pressure range. ΔP: 30-400 kPaD · 4.4-58 psid				
	Model no.			E-JUST1.G.R
	l/sec	l/hr	GPM	Red
				Setting
Nominal flow rate	0.113	406	1.79	1.0
	0.119	427	1.88	1.1
	0.125	449	1.98	1.2
	0.131	470	2.07	1.3
	0.137	492	2.17	1.4
	0.143	513	2.26	1.5
	0.149	535	2.36	1.6
	0.155	556	2.45	1.7
	0.161	578	2.54	1.8
	0.167	599	2.64	1.9
	0.172	621	2.73	2.0
	0.178	642	2.83	2.1
	0.184	664	2.92	2.2
	0.190	685	3.02	2.3
	0.196	707	3.11	2.4
	0.202	728	3.21	2.5
	0.208	750	3.30	2.6
	0.214	771	3.40	2.7
	0.220	793	3.49	2.8
	0.226	814	3.59	2.9
	0.232	836	3.68	3.0
	0.238	857	3.78	3.1
	0.244	879	3.87	3.2
	0.250	900	3.96	3.3
	0.256	922	4.06	3.4
	0.262	943	4.15	3.5
	0.268	965	4.25	3.6
	0.274	987	4.34	3.7
	0.280	1010	4.44	3.8
	0.286	1030	4.53	3.9
0.292	1050	4.63	4.0	
0.298	1070	4.72	4.1	
0.304	1090	4.82	4.2	
0.310	1120	4.91	4.3	
0.316	1140	5.01	4.4	
0.322	1160	5.10	4.5	
0.328	1180	5.20	4.6	
0.334	1200	5.29	4.7	
0.340	1220	5.38	4.8	
0.346	1240	5.48	4.9	
0.352	1270	5.57	5.0	

Accuracy: Greatest of either ±5% of controlled flow rate or ±2% of maximum flow rate

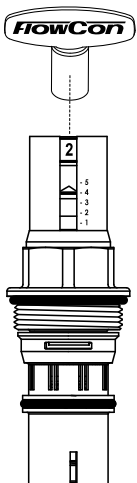
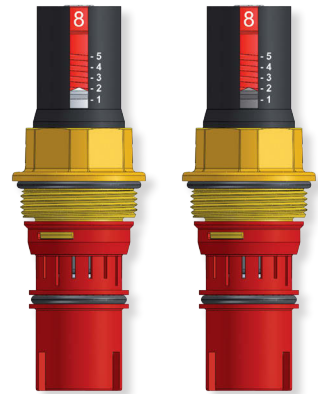

Use the FlowCon adjustment key (part number ACC0001) for adjusting the flow rate.

A setting of 4.2 corresponds to a flow rate of 0.304 l/sec for the 20mm red insert, range 30-400 kPaD.

## FLOW RATE SETTING - E-JUST INSERT - FOR VALVES DN15-DN25 SMALL (continued)

20mm · 3/4" · E-JUST · G-type · Grey pawl					
Pressure range, ΔP: 35-400 kPaD · 5.1-58 psid					
Nominal flow rate	Model no.			E-JUST1.G.B	E-JUST1.G.G
	l/sec	l/hr	GPM	Black	Green
				Setting	Setting
	0.0383	138	0.607	1.0	
	0.0416	150	0.660	1.1	
	0.0449	162	0.712	1.2	
	0.0483	174	0.765	1.3	
	0.0516	186	0.817	1.4	
	0.0549	198	0.870	1.5	
	0.0582	210	0.922	1.6	
	0.0615	221	0.975	1.7	
	0.0648	233	1.03	1.8	
	0.0660	238	1.05		1.0
	0.0681	245	1.08	1.9	
	0.0706	254	1.12		1.1
	0.0714	257	1.13	2.0	
	0.0748	269	1.18	2.1	
	0.0751	271	1.19		1.2
	0.0781	281	1.24	2.2	
	0.0797	287	1.26		1.3
	0.0814	293	1.29	2.3	
	0.0843	304	1.34		1.4
	0.0847	305	1.34	2.4	
	0.0880	317	1.40	2.5	
	0.0889	320	1.41		1.5
	0.0913	329	1.45	2.6	
	0.0934	336	1.48		1.6
	0.0946	341	1.50	2.7	
	0.0979	353	1.55	2.8	
	0.0980	353	1.55		1.7
	0.101	365	1.61	2.9	
	0.103	369	1.63		1.8
	0.105	377	1.66	3.0	
	0.107	386	1.70		1.9
	0.108	388	1.71	3.1	
	0.111	400	1.76	3.2	
	0.112	402	1.77		2.0
	0.115	412	1.82	3.3	
	0.116	419	1.84		2.1
	0.118	424	1.87	3.4	
	0.121	435	1.92		2.2
	0.121	436	1.92	3.5	
	0.124	448	1.97	3.6	
	0.125	452	1.99		2.3
	0.128	460	2.03	3.7	
	0.130	468	2.06		2.4
	0.131	472	2.08	3.8	

Continue next column...

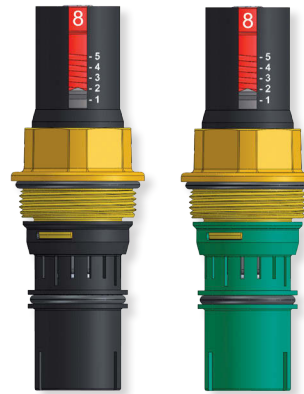

20mm · 3/4" · E-JUST · G-type · Grey pawl					
Pressure range, ΔP: 35-400 kPaD · 5.1-58 psid					
Nominal flow rate	Model no.			E-JUST1.G.B	E-JUST1.G.G
	l/sec	l/hr	GPM	Black	Green
				Setting	Setting
	0.134	484	2.13	3.9	
	0.135	485	2.13		2.5
	0.138	496	2.18	4.0	
	0.139	501	2.21		2.6
	0.141	508	2.24	4.1	
	0.144	517	2.28		2.7
	0.144	520	2.29	4.2	
	0.148	532	2.34	4.3	
	0.148	534	2.35		2.8
	0.151	544	2.39	4.4	
	0.153	550	2.42		2.9
	0.154	556	2.45	4.5	
	0.157	567	2.50		3.0
	0.158	567	2.50	4.6	
	0.161	579	2.55	4.7	
	0.162	583	2.57		3.1
	0.164	591	2.60	4.8	
	0.167	600	2.64		3.2
	0.168	603	2.66	4.9	
	0.171	615	2.71	5.0	
	0.171	616	2.71		3.3
	0.176	633	2.79		3.4
	0.180	649	2.86		3.5
	0.185	666	2.93		3.6
	0.189	682	3.00		3.7
	0.194	699	3.08		3.8
	0.199	715	3.15		3.9
	0.203	731	3.22		4.0
	0.208	748	3.29		4.1
	0.212	764	3.37		4.2
	0.217	781	3.44		4.3
	0.221	797	3.51		4.4
	0.226	814	3.58		4.5
	0.231	830	3.66		4.6
	0.235	847	3.73		4.7
	0.240	863	3.80		4.8
	0.244	880	3.87		4.9
	0.249	896	3.95		5.0

Accuracy: Greatest of either ±5% of controlled flow rate or ±2% of maximum flow rate

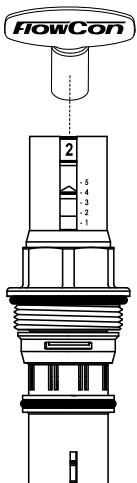

Use the FlowCon adjustment key (part number ACC0001) for adjusting the flow rate.

A setting of 4.2 corresponds to a flow rate of 0.212 l/sec for the 20mm green insert, range 35-400 kPaD.

## FLOW RATE SETTING - E-JUST INSERT - FOR VALVES DN25 LARGE-DN40

40mm · 1 1/2" · E-JUST · Y-type · White pawl				
Pressure range. ΔP: 17-400 kPaD · 2.5-58 psid				
Model no. E-JUST2.Y.G				
Nominal flow rate	l/sec	l/hr	GPM	Setting
	0.149	535	2.36	1.0
	0.220	793	3.49	1.1
	0.289	1040	4.58	1.2
	0.355	1280	5.63	1.3
	0.418	1510	6.63	1.4
	0.479	1730	7.60	1.5
	0.538	1940	8.52	1.6
	0.594	2140	9.41	1.7
	0.647	2330	10.3	1.8
	0.699	2520	11.1	1.9
	0.748	2690	11.9	2.0
	0.795	2860	12.6	2.1
	0.841	3030	13.3	2.2
	0.884	3180	14.0	2.3
	0.925	3330	14.7	2.4
	0.965	3470	15.3	2.5
	1.00	3610	15.9	2.6
	1.04	3740	16.5	2.7
	1.07	3870	17.0	2.8
1.11	3990	17.6	2.9	
1.14	4100	18.1	3.0	
1.17	4220	18.6	3.1	
1.20	4320	19.0	3.2	
1.23	4420	19.5	3.3	
1.26	4520	19.9	3.4	
1.28	4620	20.3	3.5	
1.31	4710	20.7	3.6	
1.33	4800	21.1	3.7	
1.36	4890	21.5	3.8	
1.38	4970	21.9	3.9	
1.40	5050	22.3	4.0	
1.43	5130	22.6	4.1	
1.45	5210	23.0	4.2	
1.47	5290	23.3	4.3	
1.49	5370	23.6	4.4	
1.51	5440	24.0	4.5	
1.53	5520	24.3	4.6	
1.55	5600	24.6	4.7	
1.58	5670	25.0	4.8	
1.60	5750	25.3	4.9	
1.62	5830	25.7	5.0	

Accuracy: Greatest of either ±5% of controlled flow rate or ±2% of maximum flow rate

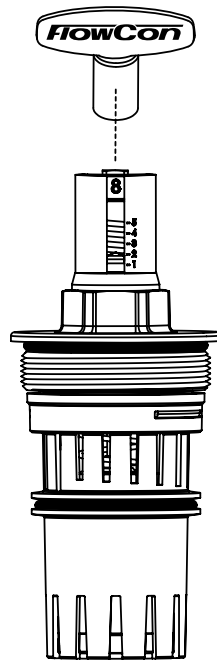
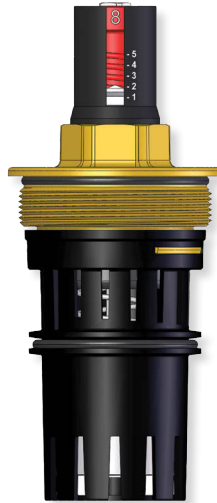

Use the FlowCon adjustment key (part number ACC0001) for adjusting the flow rate.

A setting of 4.2 corresponds to a flow rate of 1.45 l/sec for the 40mm insert, range 17-400 kPaD.

## ACCESSORIES

- P/t plugs: 2 x ACC00101
- Blind cap: ACC0080 / ACC0081 (cap (small / medium) without an insert for flushing out the system)
- Adjustment key: ACC0001 (key for adjusting the flow rate on E-JUST inserts and turning the ball valve).

## GENERAL SPECIFICATIONS

### 1. AUTOMATIC BALANCING VALVES WITH INTEGRAL ISOLATION BALL VALVE - FLOWCON ABV

- 1.1. Contractor shall install automatic balancing valves where indicated in drawings.
- 1.2. Valve shall consist of dynamic, accessible, adjustable flow limiting device and integral isolation ball valve.

### 2. VALVE HOUSING AND BALL VALVE

- 2.1. Valve housing shall consist of forged brass ASTM CuZn40Pb2, rated at no less than 2500 kPa static pressure and +120°C.
- 2.2. Valve ball shall consist of chemically nickel plated brass (ASTM CuZn40Pb2).
- 2.3. Valve housing shall be permanently marked to show direction of flow.
- 2.4. Valve housing shall be double union end constructed with a range of pipe connections available for the appropriate pipe size.
- 2.5. Optional dual pressure/temperature test plugs for verifying accuracy of flow performance shall be available for all valve sizes.
- 2.6. Housing shall be configured for flow regulation unit accessibility.

### 3.a. FLOW REGULATOR / AUTOMATIC BALANCING UNIT / COMPOSITE INSERT

- 3.a.1. Flow regulation unit assembly shall be manufactured of polyoxymethylene with a hydrogenated acrylonitrile-butadiene rubber or EPDM diaphragm and stainless steel 18-8 spring.
- 3.a.2. Flow regulation unit shall be readily accessible for change-out or maintenance.
- 3.a.3. Flow regulation unit shall be adjustable to 1 of 8 different flow rates; shall be available in 2 different kPaD operational ranges for DN15/20/25 and 3 different kPaD operational ranges for DN25/32/40; minimum range shall be capable of being activated by minimum 15 kPaD. Further, the flow regulation unit shall be capable of controlling flow within  $\pm 10\%$  of rated flow rate or 20l/hr.
- 3.a.4. Identification tags shall be available for all valves; tags shall be indelibly marked with flow rate, color and dial setting.

OR...

### 3.b. FLOW REGULATOR / AUTOMATIC BALANCING UNIT / E-JUST INSERT

- 3.b.1. Flow regulation unit assembly shall be manufactured of polysulfone with a hydrogenated acrylonitrile-butadiene rubber or EPDM diaphragm and stainless steel 18-8 spring.
- 3.b.2. Flow regulation unit shall be readily accessible for change-out or maintenance.
- 3.b.3. Flow regulation unit shall be adjustable with the valve in-line and the system in operation.
- 3.b.4. Flow regulation unit shall be externally adjustable to 1 of 41 different flow rates; shall be available in 4 different kPaD operational ranges for DN15/20/25 and 1 kPaD operational ranges for DN25/32/40; minimum range shall be capable of being activated by minimum 17 kPaD. Further, the flow regulation unit shall be capable of controlling flow within  $\pm 5\%$  of rated flow or  $\pm 2\%$  of maximum flow.
- 3.b.5. Identification tags shall be available for all valves; tags shall be indelibly marked with flow rate, color and dial setting.

## APPLICATION EXAMPLE

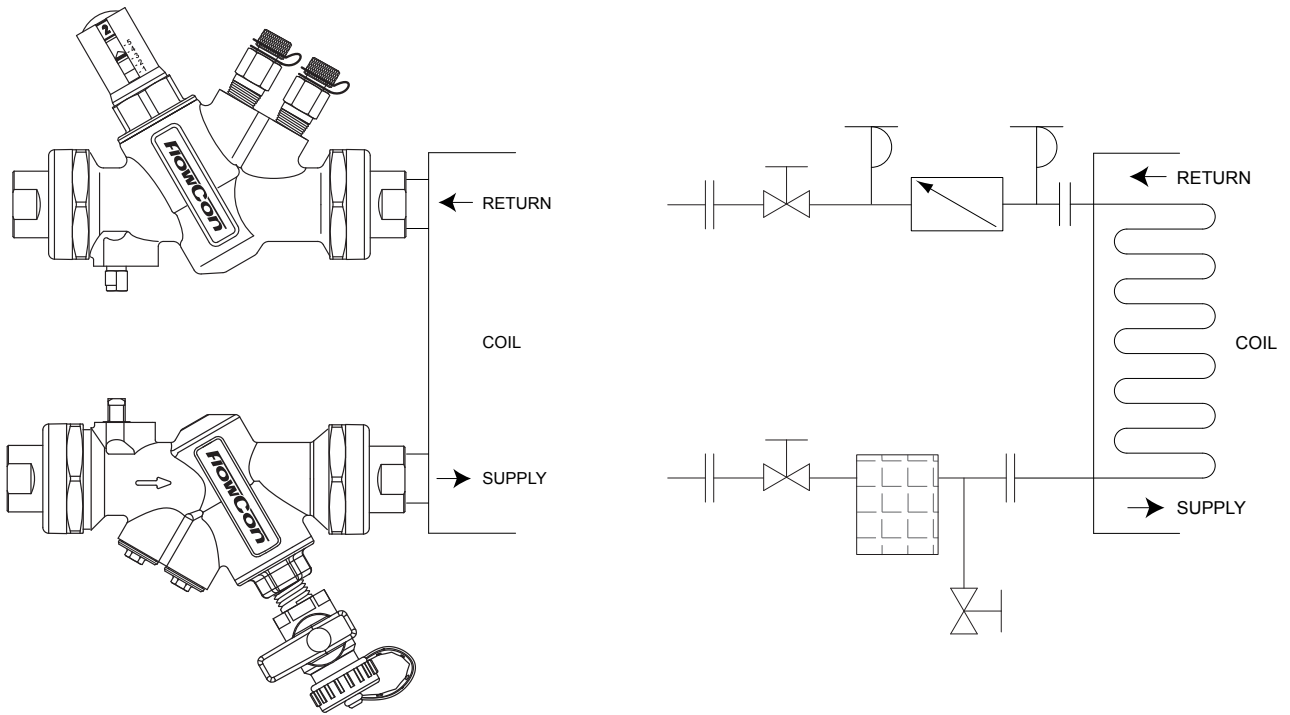

## UPDATES

**For latest updates please see [www.flowcon.com](http://www.flowcon.com)**

FlowCon International can accept no responsibility for possible errors in any printed material.  
All rights reserved.

# FlowCon SH



*Externally Adjustable Dynamic Balancing Valve*

# FlowCon SH

*Externally Adjustable Dynamic Self Balancing Valve*

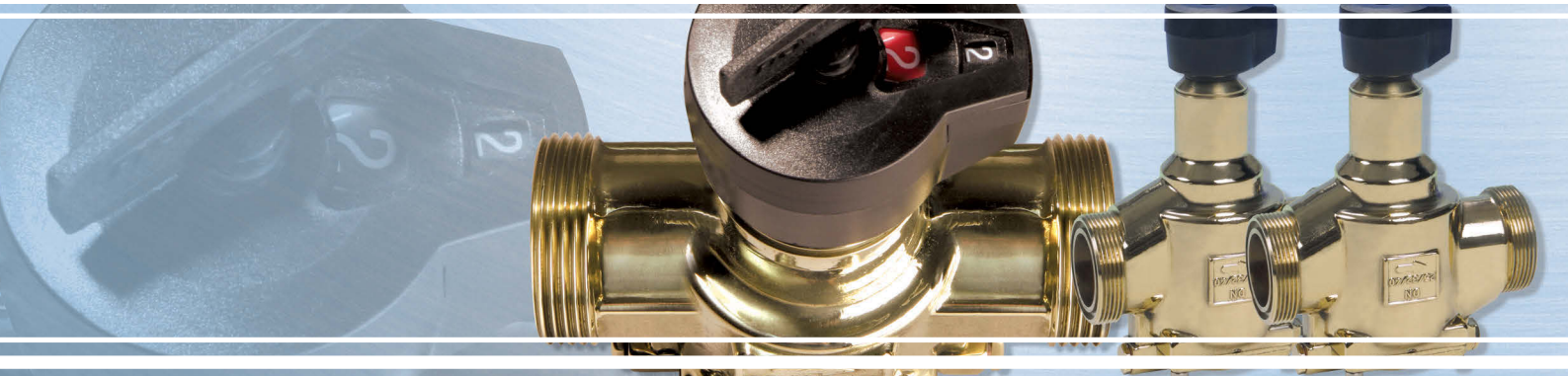

The FlowCon SH series of valves are dynamic flow controls which automatically limit the rate of flow to a pre-set, adjustable maximum.

Used as automatic/dynamic hydraulic balancing valves in multi circuit HVAC systems the more common applications include multiple fan coils, radiators and heat pumps. They can also be used in limiting the flow to individual heat exchangers or domestic water tanks.

Due to the fact that the FlowCon SH valves are externally adjustable, the desired maximum flow rate can be easily changed while the system is operating.

## **Features and Benefits**

- **Automatic flow control**, balance is achieved automatically eliminating the need for manual balancing devices.
- **Easy flow rate setting selection**, determined by one flow rate table without the need of external measurements.
- **Easy adjustment** without disturbing the balance in the rest of the system.
- **51 distinct flow rate settings** per valve size and control range.
- **Accuracy**: Greatest of either  $\pm 5\%$  of controlled flow rate or  $\pm 2\%$  of maximum flow rate.
- **Tamper-proof**, adjustment unit is being operated by means of special FlowCon key.
- **Pressure/temperature measurement plugs** available for verifying operating pressure differential range.
- **Double union end connection** with a wide selection of end fittings, or **double flange connection** for ease of installation.

## **Adjustment**

The internal mechanism is adjusted by an operation key which also turns the display mechanism. The numeric display shows two scales; one black reflecting full turns numbered 1 through 6, and one red reflecting tenths of full turns numbered 0 through 9. The number of turns reflects the flow rate selected (pls. see specific tech note for exact flow rates and settings).

After the flow rate is set, the valve automatically registers the system pressure conditions and adjusts its orifice area to limit the flow rate to the selected maximum. As system pressure conditions change, the valve will automatically adjust to maintain the selected flow rate. This eliminates the need to know exactly the distribution of pressure within a system.

Because of this dynamic reacting feature, one or more of the valves in the system can be re-adjusted without upsetting the other circuits.

The flow rate through the valve can be verified by reading the pressure differential across the valve. The pressure test ports can be supplied with optional pressure/temperature test plugs for connecting conventional mechanical gauges or electronic sensors.



### Principle of Operation

The FlowCon SH valves contain a diaphragm component mounted on a counter-acting spring which adjusts the pressure differential across a pre-set valve opening. The combined components operate very similar to two valves in series, where one is a pressure differential regulator and one an adjustable orifice. This is illustrated below.

### Principle of Construction

On the below drawings P1 and P3 are system pressure,  $P1+P3$  is the total pressure drop across the valve. P2 is set by the diaphragm acting in reaction to P1 in the lower diaphragm chamber. Interacting with the spring,  $P1+P2$  remains constant, keeping a constant  $\Delta P$  across the orifice areas. The result is a constant flow rate through the valve, independent of pressure fluctuations.

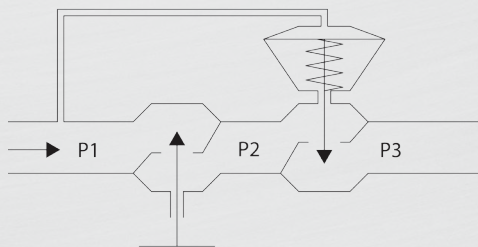

### Installation

Contrary to traditional static balancing systems, dynamic balancing requires no main branch balancing valves. If a FlowCon SH valve is used at each terminal, the total flow rate of the branch will automatically be limited to the sum of the flow rates of the circuits.

The FlowCon SH valve can either be installed in the supply or return line. The valve should be positioned for easy access to the adjustment and pressure measurement devices. Unlike traditional balancing valves, placement of the FlowCon SH does not require lengths of pipe before or after the valve.

### End Fittings

The FlowCon SH valves are available with optional union connections with a range of different end fittings. The end fittings are available in any combination of size and standard. Larger sizes are for flange connection (pls. see tech notes for further information).

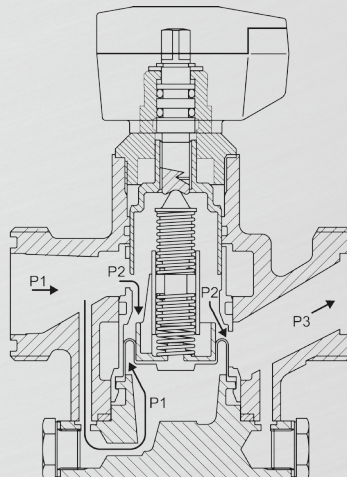

**Flow Verification**

Optional pressure/temperature test plugs are available for verifying the differential pressure across each FlowCon SH valve. They are fitted into 1/4" NPT female threaded ports. With the p/t plugs fitted, a pressure differential reading across the valve can be taken.

**Flow Rate Setting**

For adjusting the flow rate of the FlowCon SH valves use the special designed key (FlowCon part no. ACC0001). As an example, a micrometer setting at 2.4 corresponds to a flow rate of 0.29 l/sec for the valve in size 15/20/25.

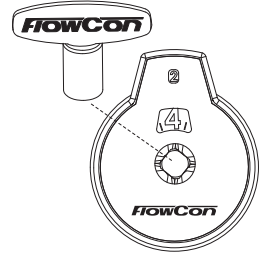

**Technical Data**

For further information please see FlowCon tech note. For latest updates please see [www.flowcon.com](http://www.flowcon.com).

	SH1 DN15/20/25	SH2 DN25/32/40	SH3 DN50/65/80			SH4 DN80/100			SH5 DN125/150		
Pressure Differential	(kPaD)	33-300	33-300	30-600	30-600	35-600	30-600	35-600	50-600	30-600	35-600
	(psid)	4.8-44	4.8-44	4.5-87	4.5-87	5.1-87	4.5-87	5.1-87	7.3-87	4.5-87	5.1-87
Flow Rate	(l/sec)	0.075-0.70	0.11-1.95	1.48-4.16	2.57-7.15	3.55-9.88	3.49-9.38	4.73-14.2	3.68-20.2	6.48-23.3	7.10-29.5
	(GPM)	1.20-11.1	1.70-30.9	23.4-66.0	40.7-113	56.3-157	55.4-149	75.0-225	58.3-320	103-369	113-468
Static Pressure	(kPa)	2500		4000							
	(psi)	360		580							
Temperature Rating (media / ambient)	(°C)	-20 to +120 / -10 to +54									
	(°F)	-4 to +248 / +14 to +131									

NOTE: For pump head calculations, add the minimum pressure differential for the index circuit to the other components pressure losses (i.e. valves, coil, etc.)



A Griswold Controls LLC./FlowCon International Company

[www.flowcon.com](http://www.flowcon.com)

D E N M A R K . D U B A I . U S A . S I N G A P O R E

# FlowCon SH 15-40mm

## Adjustable Dynamic Self Balancing Valve



### SPECIFICATIONS

Pressure rating:	2500 kPa / 360 psi
Temperature rating, media:	-20°C to +120°C / -4°F to +248°F
Material:	
- Diaphragm:	Hydrogenated acrylonitrile-butadiene-rubber
- Body:	Forged brass ASTM CuZn40Pb2
- Union end connections:	Brass alloy ISO or NPT
- O-rings:	EPDM
- Internal components:	Polysylphone (SH1) Poly-vinyl-iden-fluoride (SH2)
Body tappings:	1/4" NPT
Maximum close off pressure:	600 kPa / 87 psi
Maximum operational ΔP:	300 kPaD / 44 psid
Flow rate range:	0.075-1.95 l/sec

## DIMENSIONS AND WEIGHTS (NOMINAL) (measured in mm unless noted)

Model no.	Valve size	L	H1	H2	End connections C <sup>1</sup>			Weight (kgs.) w/o end conn.
					ISO Female	ISO Male	Sweat	
SH.1.1	15	108.0	89.9	58.9	22	24	20	1.8
	20				22	25	20	
	25				-	39	22	
SH.2.1	25	149.1	140.0	66.0	35	40	34	4.5
	32				33	40	34	
	40				33	42	-	

Note 1: Add end connection length to body length.

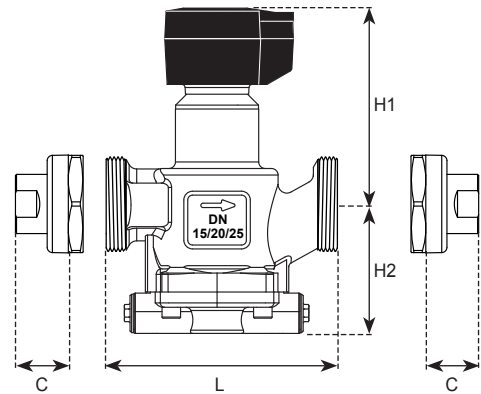

## FLOW RATE TABLE

Model no.	Valve size		Control range		Minimum setting			Maximum setting			Shut-off leakage
	mm	inch	kPaD	psid	l/sec	l/hr	GPM	l/sec	l/hr	GPM	
SH.1.1	15	1/2"	33-300	4.8-44	0.0750	270	1.20	0.700	2520	11.1	Leakage<0.05% of Kvs Kvs=4.2 m <sup>3</sup> /hr
	20	3/4"									
	25	1"									
SH.2.1	25	1"	33-300	4.8-44	0.110	396	1.70	1.95	7020	30.9	Leakage<0.05% of Kvs Kvs=11.6 m <sup>3</sup> /hr
	32	1 1/4"									
	40	1 1/2"									

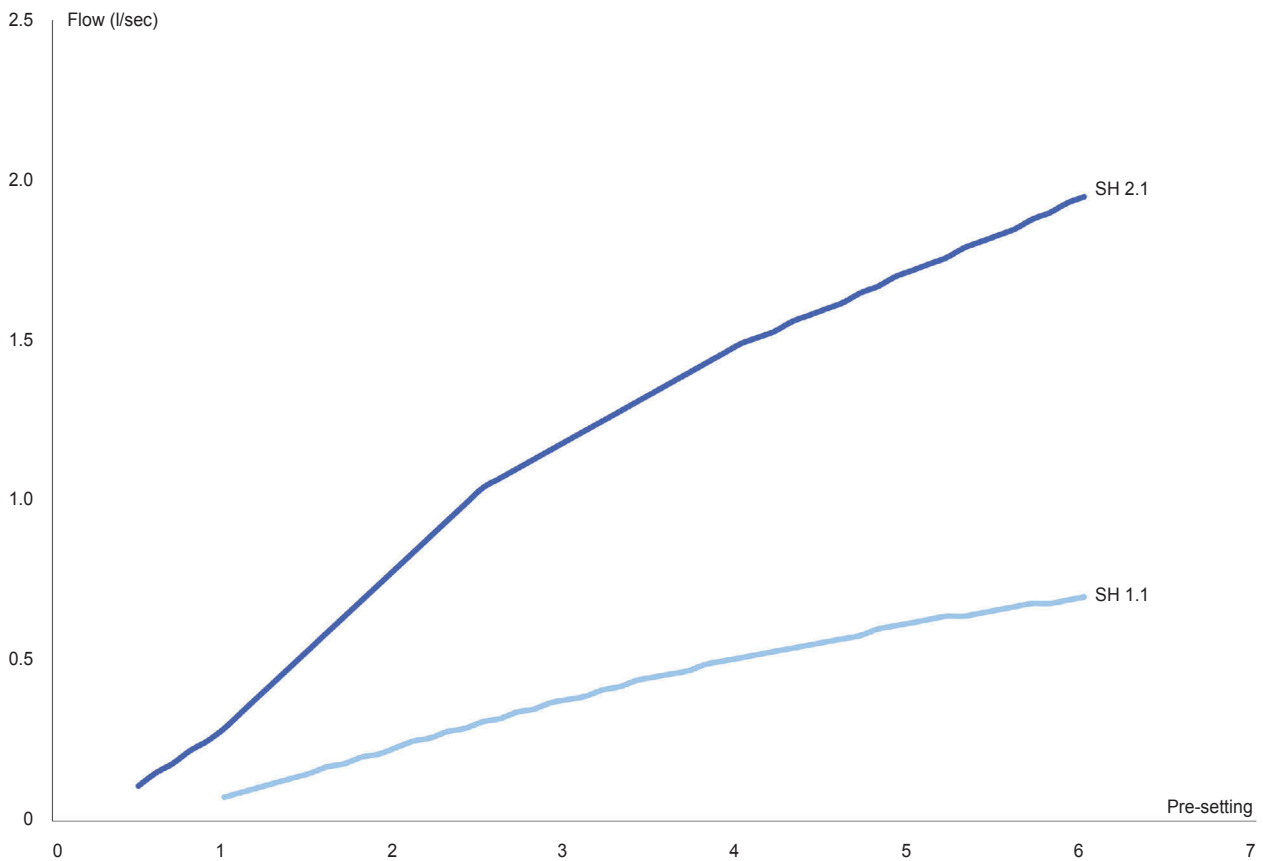

## MODEL NUMBER SELECTION

SH . . . 1 . . . . .

Insert body size:  
**1**=15-25mm **2**=25-40mm

Insert dP control range:  
**1**=standard

Insert p/t plug requirements:  
**P**=taps plugged (standard) **B**=pressure/temperature plugs

Insert inlet x outlet union end connections:

Body size	Female threaded	Male treaded	Sweat
Union end 15-25mm, 1/2"-1"	<b>E</b> =15mm=1/2" <b>F</b> =20mm=3/4"	<b>H</b> =15mm=1/2" <b>I</b> =20mm=3/4" <b>J</b> =25mm=1"	<b>K</b> =15mm <b>L</b> =18mm <b>M</b> =22mm
Union end 25-40mm, 1"-1 1/2"	<b>G</b> =25mm=1" <b>P</b> =32mm=1 1/4" <b>Q</b> =40mm=1 1/2"	<b>J</b> =25mm=1" <b>S</b> =32mm=1 1/4" <b>T</b> =40mm=1 1/2"	<b>N</b> =28mm <b>W</b> =35mm

Insert connections standard:  
**I**=ISO **N**=NPT -Leave it **blank** if no connection required

Example: SH.1.1.P.F.F.I=SH 15-25mm body, taps plugged and with 20mm ISO female threaded end connections.

## FLOW RATE SETTING - VALVE SIZE DN15-DN40

Flow rate						Setting
Valve size: DN15-DN25 · 1/2"-1"			Valve size: DN25-DN40 · 1"-1 1/2"			
33-300 kPaD · 4.8-44 psid			33-300 kPaD · 4.8-44 psid			
SH.1.1			SH.2.1			
l/sec	l/hr	GPM	l/sec	l/hr	GPM	
-	-	-	0.11	396	1.7	0.5
-	-	-	0.15	526	2.3	0.6
-	-	-	0.18	655	2.9	0.7
-	-	-	0.22	785	3.5	0.8
-	-	-	0.25	914	4.0	0.9
0.075	270	1.2	0.29	1044	4.6	1.0
0.090	324	1.4	0.34	1224	5.4	1.1
0.105	378	1.7	0.39	1404	6.2	1.2
0.120	432	1.9	0.44	1584	7.0	1.3
0.135	486	2.1	0.49	1764	7.8	1.4
0.15	540	2.4	0.54	1944	8.6	1.5
0.17	598	2.6	0.59	2124	9.4	1.6
0.18	655	2.9	0.64	2304	10.1	1.7
0.20	713	3.1	0.69	2484	10.9	1.8
0.21	770	3.4	0.74	2664	11.7	1.9
0.23	828	3.6	0.79	2844	12.5	2.0
0.25	886	3.9	0.84	3024	13.3	2.1
0.26	943	4.2	0.89	3204	14.1	2.2
0.28	1001	4.4	0.94	3384	14.9	2.3
0.29	1058	4.7	0.99	3564	15.7	2.4
0.31	1116	4.9	1.04	3744	16.5	2.5
0.32	1166	5.1	1.07	3852	17.0	2.6
0.34	1217	5.4	1.10	3960	17.4	2.7
0.35	1267	5.6	1.13	4068	17.9	2.8
0.37	1318	5.8	1.16	4176	18.4	2.9
0.38	1368	6.0	1.19	4284	18.9	3.0
0.39	1418	6.2	1.22	4392	19.3	3.1
0.41	1469	6.5	1.25	4500	19.8	3.2
0.42	1519	6.7	1.28	4608	20.3	3.3
0.44	1570	6.9	1.31	4716	20.8	3.4
0.45	1620	7.1	1.34	4824	21.2	3.5
0.46	1663	7.3	1.37	4932	21.7	3.6
0.47	1706	7.5	1.40	5040	22.2	3.7
0.49	1750	7.7	1.43	5148	22.7	3.8
0.50	1793	7.9	1.46	5256	23.1	3.9
0.51	1836	8.1	1.49	5364	23.6	4.0
0.52	1872	8.2	1.51	5443	24.0	4.1
0.53	1908	8.4	1.53	5522	24.3	4.2
0.54	1944	8.6	1.56	5602	24.7	4.3
0.55	1980	8.7	1.58	5681	25.0	4.4
0.56	2016	8.9	1.60	5760	25.4	4.5
0.57	2059	9.1	1.62	5846	25.7	4.6
0.58	2102	9.3	1.65	5933	26.1	4.7
0.60	2146	9.4	1.67	6019	26.5	4.8
0.61	2189	9.6	1.70	6106	26.9	4.9
0.62	2232	9.8	1.72	6192	27.3	5.0
0.63	2261	10.0	1.74	6271	27.6	5.1
0.64	2290	10.1	1.76	6350	28.0	5.2
0.64	2318	10.2	1.79	6430	28.3	5.3
0.65	2347	10.3	1.81	6509	28.7	5.4
0.66	2376	10.5	1.83	6588	29.0	5.5
0.67	2405	10.6	1.85	6674	29.4	5.6
0.68	2434	10.7	1.88	6761	29.8	5.7
0.68	2462	10.8	1.90	6847	30.1	5.8
0.69	2491	11.0	1.93	6934	30.5	5.9
0.70	2520	11.1	1.95	7020	30.9	6.0

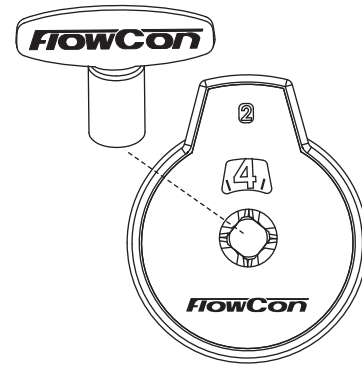

Use the special key (FlowCon part no. ACC0001) for micrometer setting.

A micrometer setting at 2.4 as illustrated above corresponds to a flow rate of:

0.29 l/sec (for valve size DN15/20/25)  
0.99 l/sec (for valve size DN25/32/40)

Accuracy: Greatest of either  $\pm 5\%$  of controlled flow rate or  $\pm 2\%$  of maximum flow rate.

## ACCESSORIES

- Adjustment key, ACC0001
- Pressure/temperature plugs 1/4", 2 x ACC00101

## GENERAL SPECIFICATIONS

### 1. DYNAMIC BALANCING VALVES - FLOWCON SH

- 1.1. Contractor shall install dynamic balancing valves where indicated in drawings.
- 1.2. Valve shall consist of dynamic, adjustable flow limiting device.
- 1.3. Flow limiting device shall be externally adjustable with the valve in-line and the system in operation.

### 2. VALVE HOUSING

- 2.1. Valve housing shall consist of forged brass ASTM CuZn40Pb2, rated at no less than 2500 kPa static pressure and +120°C.
- 2.2. Valve housing shall be permanently marked to show direction of flow.
- 2.3. Valve housing shall be double union construction with a range of pipe connections available for the appropriate pipe size.
- 2.4. Optional dual pressure/temperature test plugs for verifying accuracy of flow performance shall be available for all valve sizes.

### 3. FLOW REGULATOR / AUTOMATIC BALANCING UNIT

- 3.1. Flow regulation unit shall be manufactured of polysylphone / poly-vinyl-iden-fluoride (depending on size) and hydrogenated acrylonitrile-butadiene-rubber.
- 3.2. Flow regulation unit shall be accessible for maintenance.
- 3.3. Housing shall be configured for external flow regulation unit adjustment to 56 different flow rates and shall be capable of controlling flow within greatest of either  $\pm 5\%$  of rated flow or  $\pm 2\%$  of maximum rated flow.

## 2-WAY APPLICATION AND SCHEMATIC EXAMPLE

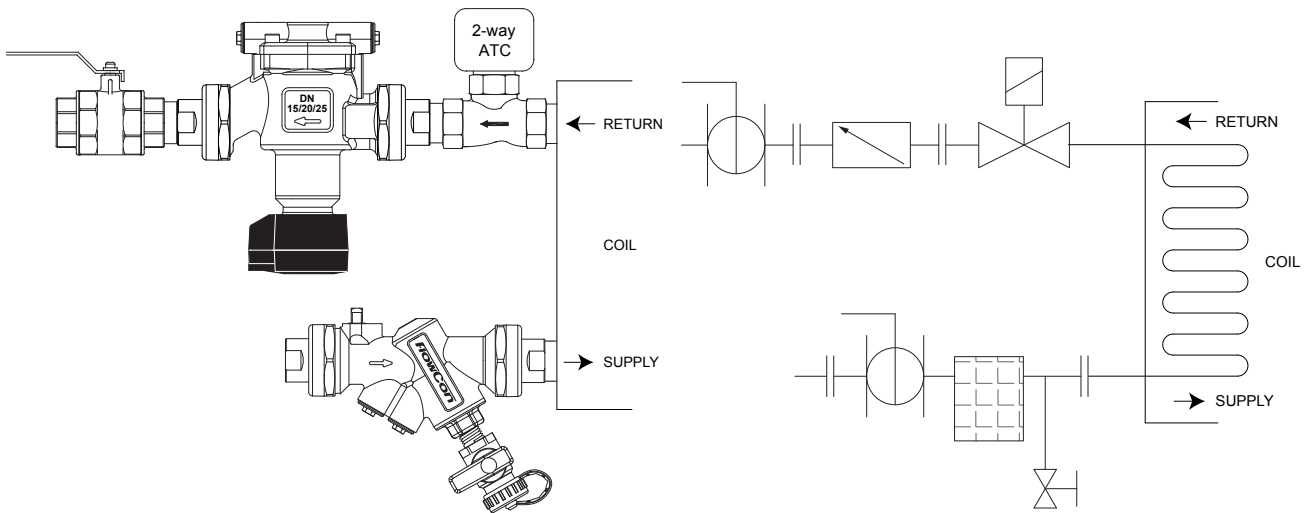

## 3-WAY APPLICATION AND SCHEMATIC EXAMPLE

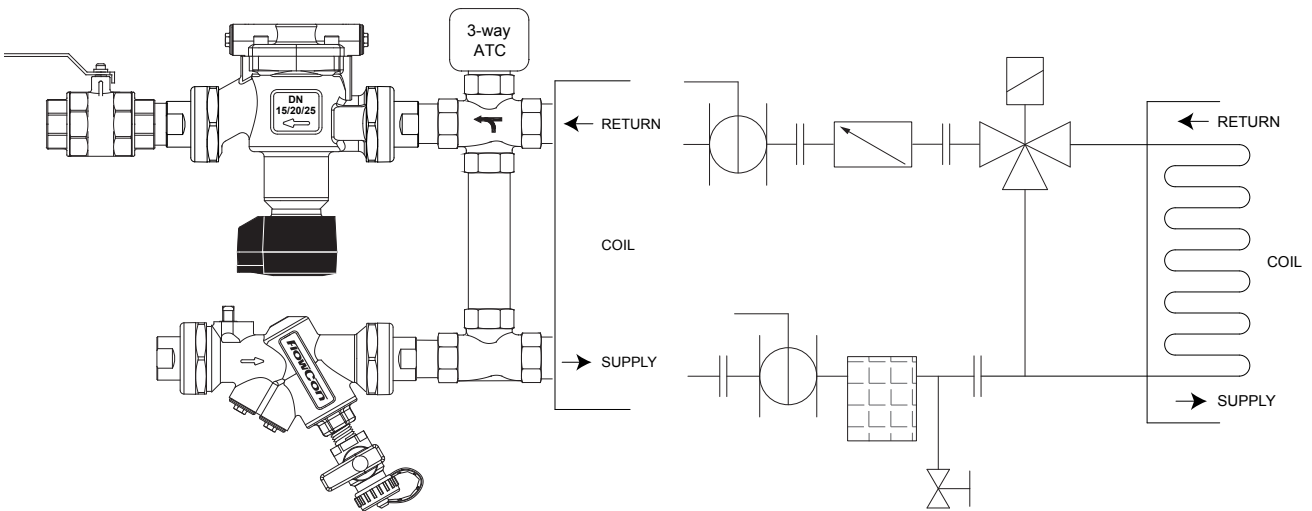

## UPDATES

For latest updates please see [www.flowcon.com](http://www.flowcon.com)

FlowCon International can accept no responsibility for possible errors in any printed material. All rights reserved.

# FlowCon SH 50-150mm

## Adjustable Dynamic Self Balancing Valve



### SPECIFICATIONS

Pressure rating:	4000 kPa / 580 psi
Temperature rating, media:	-20°C to +120°C / -4°F to +248°F
Material:	
- Diaphragm:	Hydrogenated acrylonitrile-butadiene-rubber
- Body:	Ductile iron, ASTM A395 Grade 60-40-18
- O-rings:	EPDM
- Internal components:	Stainless steel
End connection:	Universal flange connections which can be used with both ISO and ANSI Flanges and mounting kits are not supplied by FlowCon <sup>1</sup>
Body tappings:	1/4" ISO
Maximum close off pressure:	600 kPa / 87 psi
Maximum operational ΔP:	600 kPaD / 87 psid
Maximum allowable operating pressure:	1600 kPaD / 232 psid
Flow rate range:	1.48-29.5 l/sec

Note1: 2x16mm studs and 4x16mm bolts with nuts are supplied with SH.3.X.X.X.

## DIMENSIONS AND WEIGHTS (NOMINAL) (measured in mm unless noted)

Model no.	Valve size	L	H1	H2	Weight (kgs.)
SH.3.X	50	224	152	95	14 <sup>2</sup>
	65				
	80				
SH.4.X	80	320	196	135	30
	100				31 (SH.4.3 only)
SH.5.X	125	422	244	180	60
	150				

Note 2: Including studs, bolts and nuts provided with valve.

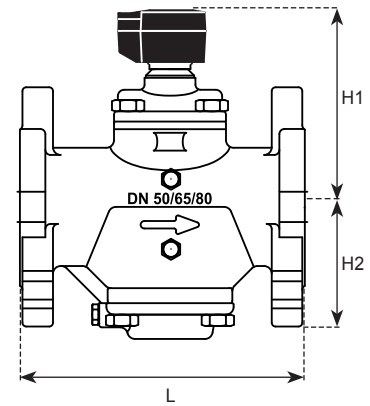

## MODEL NUMBER SELECTION

Insert valve body size:  
**3**=50-80mm   **4**=80-100mm   **5**=125-150mm

Insert dP control range:  
**0**=30-600 kPaD, 4.5-87 psid (SH.3 only)  
**1**=30-600 kPaD, 4.5-87 psid  
**2**=35-600 kPaD, 5.1-87 psid  
**3**=50-600 kPaD, 7.3-87 psid (SH.4 only)

Insert p/t plug requirements:  
**B**=p/t plugs (standard)

Example: SH.3.1.B=SH 50-80mm body for 30-600 kPaD with p/t plugs.

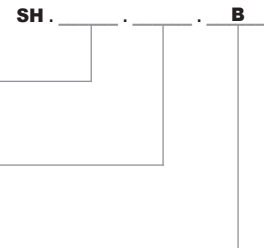

## FLANGE MATCH SH HOUSING

Model no.	Flange size (inch)	ASME B16.5 weld neck flanges		ASME B16.5 slip on flanges		Flange size (mm)	EN1092-1 <sup>3</sup>				EN1092-1 <sup>4</sup>				
		Class 150	Class 300	Class 150	Class 300		PN10	PN16	PN25	PN40	PN10	PN16	PN25	PN40	
SH.3.x	2	-	✓	-	✓	50	✓	✓	✓	✓	✓	✓	✓	✓	✓
	2 1/2	✓	✓	✓	✓	65	✓	✓	✓	✓	✓	✓	✓	✓	✓
	3	✓	✓	-	-	80	✓	✓	✓	✓	-	-	-	-	-
SH.4.x	3	✓	✓	✓	✓	80	✓	✓	✓	✓	✓	✓	✓	✓	✓
	4	✓	✓	-	-	100	✓	✓	✓	✓	-	-	-	-	-
SH.5.x	5	✓	✓	✓	✓	125	✓	✓	✓	✓	✓	✓	✓	✓	✓
	6	✓	-	-	-	150	✓	✓	✓	✓	-	-	-	-	-

Note 3: Type 02 and 35/36/37 (loose plate flange with welding neck / pressed collar with long neck / pressed collar) or Type 04 and 34 (loose plate flange with weld-neck collar) or Type 11 with flange facing A/B (weld-neck flange with flat face or raised face).

Note 4: Type 12 with flange facing A/B (hubbed slip-on flange with flat face or raised face).

## FLOW RATE TABLE

Model no.	Valve size		Control range		Minimum setting			Maximum setting		
	mm	inch	kPaD	psid	l/sec	l/hr	GPM	l/sec	l/hr	GPM
SH.3.0	50	2"	30-600	4.5-87	1.48	5310	23.4	4.16	15000	66.0
	65	2 1/2"								
	80	3"								
SH.3.1	50	2"	30-600	4.5-87	2.57	9240	40.7	7.15	25700	113
	65	2 1/2"								
	80	3"								
SH.3.2	60	2"	35-600	5.1-87	3.55	12800	56.3	9.88	35600	157
	65	2 1/2"								
	80	3"								
SH.4.1	80	3"	30-600	4.5-87	3.49	12600	55.4	9.38	33800	149
	100	4"								
SH.4.2	80	3"	35-600	5.1-87	4.73	17000	75.0	14.2	51000	225
	100	4"								
SH.4.3	80	3"	50-600	7.3-87	3.68	13300	58.3	20.2	72700	320
	100	4"								
SH.5.1	125	5"	30-600	4.5-87	6.48	23300	103	23.3	83800	369
	150	6"								
SH.5.2	125	5"	35-600	5.1-87	7.10	25600	113	29.5	106000	468
	150	6"								

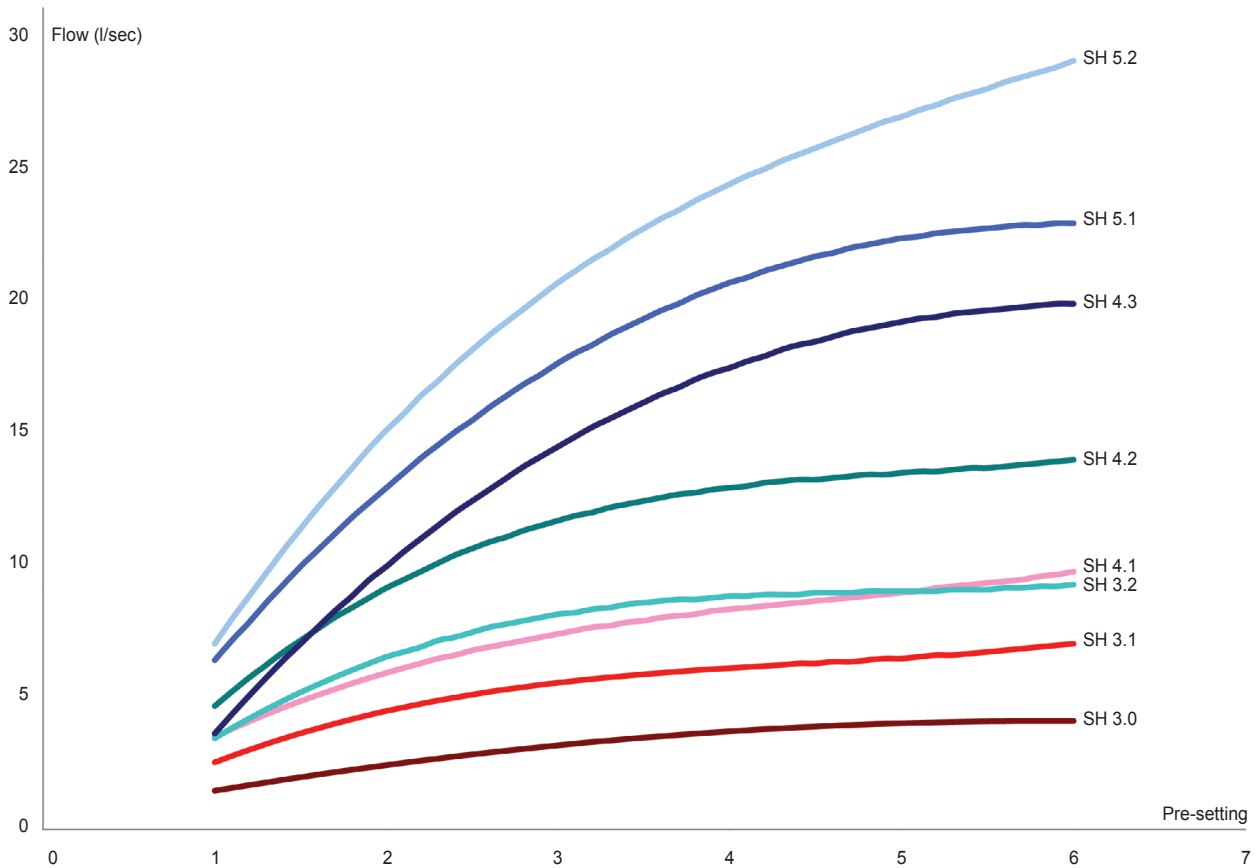

## FLOW RATE SETTING - VALVE SIZE DN50-DN80

Flow rate									Setting
Valve size: DN50-DN80 · 2"-3"									
30-600 kPaD · 4.5-87 psid			30-600 kPaD · 4.5-87 psid			35-600 kPaD · 5.1-87 psid			
SH.3.0			SH.3.1			SH.3.2			
l/sec	l/hr	GPM	l/sec	l/hr	GPM	l/sec	l/hr	GPM	
1.48	5310	23.4	2.57	9240	40.7	3.55	12800	56.3	1.0
1.58	5700	25.1	2.81	10100	44.6	3.85	13900	61.0	1.1
1.69	6080	26.8	3.05	11000	48.4	4.13	14900	65.6	1.2
1.79	6460	28.5	3.27	11800	51.9	4.41	15900	69.9	1.3
1.90	6830	30.1	3.48	12500	55.3	4.67	16800	74.0	1.4
2.00	7190	31.7	3.69	13300	58.5	4.92	17700	78.0	1.5
2.09	7540	33.2	3.88	14000	61.5	5.16	18600	81.8	1.6
2.19	7880	34.7	4.06	14600	64.3	5.38	19400	85.4	1.7
2.28	8210	36.2	4.23	15200	67.0	5.60	20200	88.8	1.8
2.37	8540	37.6	4.39	15800	69.6	5.81	20900	92.1	1.9
2.46	8860	39.0	4.54	16300	72.0	6.01	21600	95.3	2.0
2.55	9170	40.4	4.68	16900	74.3	6.19	22300	98.2	2.1
2.63	9470	41.7	4.82	17300	76.4	6.37	22900	101	2.2
2.71	9770	43.0	4.94	17800	78.4	6.54	23600	104	2.3
2.79	10100	44.3	5.06	18200	80.3	6.70	24100	106	2.4
2.87	10300	45.5	5.17	18600	82.1	6.86	24700	109	2.5
2.94	10600	46.7	5.28	19000	83.7	7.00	25200	111	2.6
3.02	10900	47.9	5.37	19300	85.2	7.14	25700	113	2.7
3.09	11100	49.0	5.47	19700	86.7	7.27	26200	115	2.8
3.16	11400	50.1	5.55	20000	88.0	7.40	26600	117	2.9
3.22	11600	51.1	5.63	20300	89.3	7.52	27100	119	3.0
3.29	11800	52.1	5.70	20500	90.5	7.63	27500	121	3.1
3.35	12100	53.1	5.77	20800	91.6	7.74	27900	123	3.2
3.41	12300	54.0	5.84	21000	92.6	7.84	28200	124	3.3
3.46	12500	54.9	5.90	21200	96.5	7.94	28600	126	3.4
3.52	12700	55.8	5.95	21400	94.4	8.03	28900	127	3.5
3.57	12900	56.6	6.01	21600	95.3	8.12	29200	129	3.6
3.62	13000	57.4	6.06	21800	96.1	8.20	29500	130	3.7
3.67	13200	58.2	6.10	22000	96.8	8.28	29800	131	3.8
3.72	13400	58.9	6.15	22100	97.5	8.36	30100	133	3.9
3.76	13500	59.6	6.19	22300	98.2	8.44	30400	134	4.0
3.80	13700	60.3	6.23	22400	98.9	8.51	30600	135	4.1
3.84	13800	60.9	6.27	22600	99.5	8.58	30900	136	4.2
3.88	14000	61.5	6.31	22700	100	8.65	31100	137	4.3
3.91	14100	62.0	6.35	22900	101	8.72	31400	138	4.4
3.94	14200	62.5	6.39	23000	101	8.78	31600	139	4.5
3.97	14300	63.0	6.42	23100	102	8.85	31900	140	4.6
4.00	14400	63.4	6.46	23300	102	8.91	32100	141	4.7
4.03	14500	63.9	6.50	23400	103	8.98	32300	142	4.8
4.05	14600	64.2	6.54	23500	104	9.04	32600	143	4.9
4.07	14700	64.6	6.58	23700	104	9.11	32800	144	5.0
4.09	14700	64.9	6.62	23800	105	9.18	33000	146	5.1
4.11	14800	65.1	6.67	24000	106	9.25	33300	147	5.2
4.12	14800	65.3	6.72	24200	107	9.32	33500	148	5.3
4.13	14900	65.5	6.77	24400	107	9.39	33800	149	5.4
1.14	14900	65.7	6.82	24600	108	9.46	34100	150	5.5
4.15	14900	65.8	6.88	24800	109	9.54	34300	151	5.6
4.15	15000	65.9	6.94	25000	110	9.62	34600	153	5.7
4.16	15000	65.9	7.01	25200	111	9.70	34900	154	5.8
4.16	15000	66.0	7.08	25500	112	9.79	35300	155	5.9
4.16	15000	66.0	7.15	25700	113	9.88	35600	157	6.0

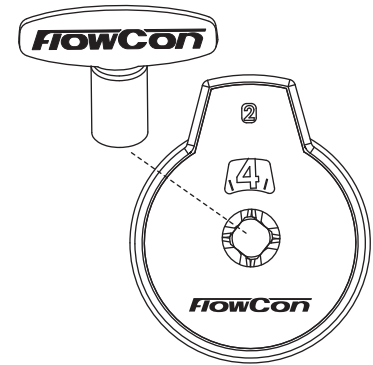

Use the special key (FlowCon part no. ACC0001) for micro-meter setting.

A micrometer setting at 2.4 as illustrated above corresponds to a flow rate of:

2.79 l/sec  
- (type 0, range 30-600 kPaD)

5.06 l/sec  
- (type 1, range 30-600 kPaD)

6.70 l/sec  
- (type 2, range 35-600 kPaD)

Accuracy: Greatest of either  $\pm 5\%$  of controlled flow rate or  $\pm 2\%$  of maximum flow rate.

## FLOW RATE SETTING - VALVE SIZE DN80 AND DN100

Flow rate									Setting
Valve size: 80mm, 100mm · 3", 4"									
30-600 kPaD · 4.5-87 psid			35-600 kPaD · 5.1-87 psid			50-600 kPaD · 7.3-87 psid			
SH.4.1			SH.4.2			SH.4.3			
l/sec	l/hr	GPM	l/sec	l/hr	GPM	l/sec	l/hr	GPM	
3.49	12600	55.4	4.73	17000	75.0	3.68	13300	58.3	1.0
3.88	14000	61.6	5.29	19000	83.9	4.42	15900	70.0	1.1
4.26	15300	67.5	5.82	21000	92.3	5.13	18500	81.3	1.2
4.61	16600	73.1	6.33	22800	100	5.82	21000	92.3	1.3
4.94	17800	78.4	6.82	24500	108	6.50	23400	103	1.4
5.26	18900	83.4	7.28	26200	115	7.15	25700	113	1.5
5.56	20000	88.2	7.72	27800	122	7.78	28000	123	1.6
5.84	21000	92.7	8.14	29300	129	8.39	30200	133	1.7
6.11	22000	96.9	8.54	30700	135	8.99	32400	142	1.8
6.36	22900	101	8.91	32100	141	9.56	34400	152	1.9
6.60	23800	105	9.27	33400	147	10.1	36400	160	2.0
6.82	24600	108	9.61	34600	152	10.7	38400	169	2.1
7.03	25300	112	9.93	35700	157	11.2	40200	177	2.2
7.23	26000	115	10.2	36800	162	11.7	42100	185	2.3
7.41	26700	117	10.5	37800	167	12.2	43800	193	2.4
7.58	27300	120	10.8	38800	171	12.6	45500	200	2.5
7.73	27800	123	11.0	39700	175	13.1	47100	207	2.6
7.88	28400	125	11.3	40500	179	13.5	48700	214	2.7
8.01	28800	127	11.5	41300	182	13.9	50200	221	2.8
8.14	29300	129	11.7	42000	185	14.3	51600	227	2.9
8.25	29700	131	11.9	42700	188	14.7	53000	233	3.0
8.35	30100	132	12.0	43400	191	15.1	54300	239	3.1
8.45	30400	134	12.2	43900	194	15.4	55600	245	3.2
8.53	30700	135	12.4	44500	196	15.8	56800	250	3.3
8.61	31000	137	12.5	45000	198	16.1	58000	255	3.4
8.68	31300	138	12.6	45500	200	16.4	59100	260	3.5
8.74	31500	139	12.7	45900	202	16.7	60200	265	3.6
8.80	31700	140	12.9	46300	204	17.0	61200	269	3.7
8.85	31900	140	13.0	46700	206	17.3	62100	274	3.8
8.90	32000	141	13.1	47000	207	17.5	63000	278	3.9
8.93	32200	142	13.1	47300	208	17.8	63900	281	4.0
8.97	32300	142	13.2	47600	210	18.0	64700	285	4.1
9.00	32400	143	13.3	47800	211	18.2	65500	288	4.2
9.03	32500	143	13.4	48100	212	18.4	66200	292	4.3
9.05	32600	144	13.4	48300	213	18.6	66900	295	4.4
9.07	32600	144	13.5	48500	214	18.8	67600	297	4.5
9.09	32700	144	13.5	48700	214	18.9	68200	300	4.6
9.10	32800	144	13.6	48800	215	19.1	68700	303	4.7
9.12	32800	145	13.6	49000	216	19.2	69200	305	4.8
9.13	32900	145	13.7	49200	217	19.4	69700	307	4.9
9.15	32900	145	13.7	49300	217	19.5	70200	309	5.0
9.16	33000	145	13.7	49500	218	19.6	70600	311	5.1
9.18	33000	146	13.8	49600	219	19.7	70900	312	5.2
9.19	33100	146	13.8	49800	219	19.8	71300	314	5.3
9.21	33200	146	13.9	49900	220	19.9	71600	315	5.4
9.23	33200	146	13.9	50100	221	20.0	71900	316	5.5
9.25	33300	147	14.0	50200	221	20.0	72100	317	5.6
9.28	33400	147	14.0	50400	222	20.1	72300	318	5.7
9.31	33500	148	14.1	50600	223	20.1	72500	319	5.8
9.34	33600	148	14.1	50800	224	20.2	72600	320	5.9
9.38	33800	149	14.2	51000	225	20.2	72700	320	6.0

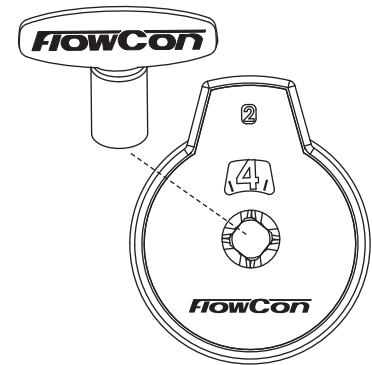

Use the special key (FlowCon part no. ACC0001) for micrometer setting.

A micrometer setting at 2.4 as illustrated above corresponds to a flow rate of:

7.41 l/sec  
- (type 1, range 30-600 kPaD)

10.5 l/sec  
- (type 2, range 35-600 kPaD)

12.2 l/sec  
- (type 3, range 50-600 kPaD)

Accuracy: Greatest of either  $\pm 5\%$  of controlled flow rate or  $\pm 2\%$  of maximum flow rate.

## FLOW RATE SETTING - VALVE SIZE DN125 AND DN150

Flow rate						Setting
Valve size: DN125 and DN150 · 5" and 6"						
30-600 kPaD · 4.5-87 psid			35-600 kPaD · 5.1-87 psid			
SH.5.1			SH.5.2			
l/sec	l/hr	GPM	l/sec	l/hr	GPM	
6.48	23300	103	7.10	25600	113	1.0
7.24	26100	115	8.06	29000	128	1.1
7.98	28700	127	8.98	32300	142	1.2
8.69	31300	138	9.87	35500	157	1.3
9.39	33800	149	10.7	38600	170	1.4
10.1	36200	160	11.6	41600	183	1.5
10.7	38600	170	12.4	44500	196	1.6
11.4	40900	180	13.1	47300	208	1.7
12.0	43100	190	13.9	50000	220	1.8
12.6	45200	199	14.6	52600	232	1.9
13.1	47300	208	15.3	55100	243	2.0
13.7	49300	217	16.0	57500	253	2.1
14.2	51200	226	16.6	59800	264	2.2
14.7	53100	234	17.2	62100	274	2.3
15.3	54900	242	17.8	64200	283	2.4
15.7	56600	250	18.4	66300	292	2.5
16.2	58300	257	19.0	68300	301	2.6
16.6	59900	264	19.5	70200	309	2.7
17.1	61500	271	20.0	72100	317	2.8
17.5	63000	277	20.5	73800	325	2.9
17.9	64400	284	21.0	75500	333	3.0
18.3	65800	290	21.4	77200	340	3.1
18.6	67100	295	21.9	78700	347	3.2
19.0	68300	301	22.3	80200	353	3.3
19.3	69500	306	22.7	81700	360	3.4
19.6	70700	311	23.1	83100	366	3.5
19.9	71700	316	23.4	84400	372	3.6
20.2	72800	321	23.8	85700	377	3.7
20.5	73800	325	24.1	86900	383	3.8
20.7	74700	329	24.5	88100	388	3.9
21.0	75600	333	24.8	89200	393	4.0
21.2	76400	337	25.1	90300	398	4.1
21.4	77200	340	25.4	91400	403	4.2
21.6	77900	343	25.7	92400	407	4.3
21.8	78600	346	25.9	93400	411	4.4
22.0	79200	349	26.2	94300	415	4.5
22.2	79800	352	26.5	95200	420	4.6
22.3	80300	354	26.7	96100	423	4.7
22.5	80800	356	26.9	97000	427	4.8
22.6	81300	358	27.2	97800	431	4.9
22.7	81700	360	27.4	98600	435	5.0
22.8	82100	362	27.6	99400	438	5.1
22.9	82400	363	27.8	100000	442	5.2
23.0	82700	364	28.1	101000	445	5.3
23.0	83000	366	28.3	102000	448	5.4
23.1	83200	367	28.5	102000	452	5.5
23.2	83400	367	28.7	103000	455	5.6
23.2	83500	368	28.9	104000	458	5.7
23.2	83600	368	29.1	105000	461	5.8
23.3	83700	369	29.3	105000	465	5.9
23.3	83800	369	29.5	106000	468	6.0

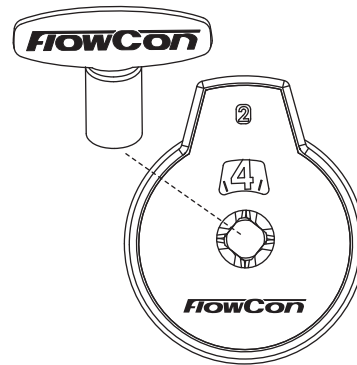

Use the special key (FlowCon part no. ACC0001) for micrometer setting.

A micrometer setting at 2.4 as illustrated above corresponds to a flow rate of:

15.3 l/sec (type 1, range 30-600 kPaD)

17.8 l/sec (type 2, range 35-600 kPaD)

Accuracy: Greatest of either  $\pm 5\%$  of controlled flow rate or  $\pm 2\%$  of maximum flow rate.

## ACCESSORIES

- Adjustment key: ACC0001 (key for adjusting the flow rate).

## GENERAL DESCRIPTION

The SH valve series are dynamic self balancing valves that are pressure independent.

The valve self-adjusts for pressure differential and therefore eliminates the need for manual adjustment according to pressure differential after installation as is required with manual balancing valves.

The valve self-adjusts to prevent exceeding design flow setting even as system pressure differential fluctuates with operation while valve is within its pressure differential control range.

Each valve has 51 different flow settings. The valve is wafer body design for installation between flanges.

## GENERAL SPECIFICATIONS

### 1. DYNAMIC BALANCING VALVES - FLOWCON SH

- 1.1. Contractor shall install dynamic balancing valves where indicated in drawings.
- 1.2. Valve shall consist of dynamic, adjustable flow limiting device.
- 1.3. Flow limiting device shall be externally adjustable with the valve in-line and the system in operation.

### 2. VALVE HOUSING

- 2.1. Valve housing shall consist of ductile iron ASTM A395 Grade 60-40-18, rated at no less than 4000 kPa static pressure and +120°C.
- 2.2. Valve housing shall be permanently marked to show direction of flow.
- 2.3. Valve housing shall be for installation between flanges, compatible with ANSI B 16.5 150lb/300lb steel flanges (depending on size) and be compatible to DIN PN10+ flanges according to EN1092-1.
- 2.4. Dual pressure/temperature test plugs for verifying accuracy of flow performance shall be provided for all valve sizes.

### 3. FLOW REGULATOR / AUTOMATIC BALANCING UNIT

- 3.1. Flow regulation unit shall be manufactured of stainless steel and hydrogenated acrylonitrile-butadiene-rubber.
- 3.2. Flow regulation unit shall be accessible for maintenance.
- 3.3. Flow regulation unit shall be adjustable with the valve in-line and the system in operation.
- 3.4. Valve housing shall be configured for external flow regulation unit adjustment to 51 different flow rates and shall be capable of controlling flow with an accuracy of either  $\pm 5\%$  of rated flow or  $\pm 2\%$  of maximum flow whichever is greatest.
- 3.5. Identification label according to PED-requirements shall be available for all valves.

## 2-WAY APPLICATION AND SCHEMATIC EXAMPLE

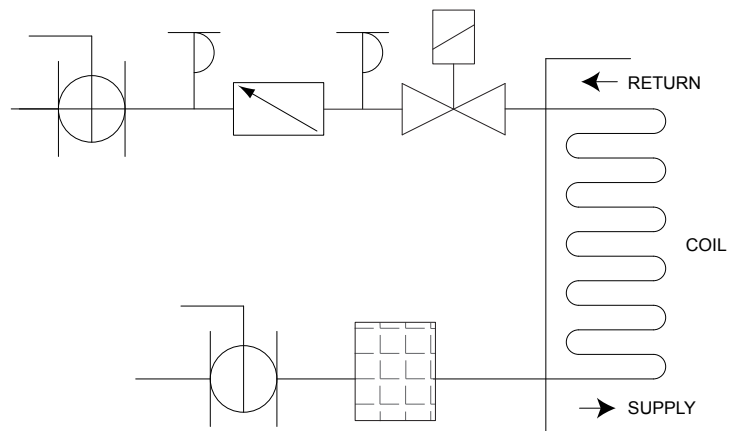
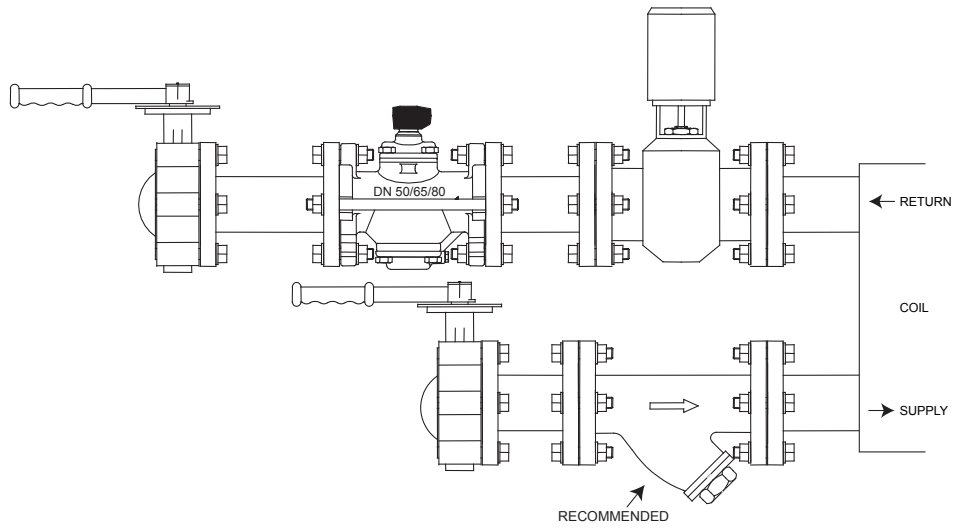

## UPDATES

For latest updates please see [www.flowcon.com](http://www.flowcon.com)

FlowCon International can accept no responsibility for possible errors in any printed material. All rights reserved.

# FlowCon K



*Automatic Flow Control Valve with Pressure Regulation*

# FlowCon K

## Dynamic Flow Control Valve



The FlowCon K series are designed as a constant flow valve which maintains a specific flow rate independent of pressure fluctuations within a hydronic heating or cooling system. FlowCon K is primarily designed for use in terminal balancing.

The flow rate for the application is selected and FlowCon K does the rest, eliminating time consuming and costly manual balancing. Whether the application is air conditioning or heating, terminal unit or branch balancing, constant or modulating flow, the FlowCon K is the most accurate yet flexible way of balancing any hydronic system completely automatic.

### Features and Benefits

- **Automatic balancing**, the correct flow rate for each circuit is achieved automatically.
- **Dynamic balancing**, the correct flow rate is maintained as each valve compensates for pressure fluctuations in the system.
- **Elimination of branch or "partner" balancing valves** (fewer total valves used in each project).
- **Easily accessible insert** for flow rate changing or maintenance.
- **Accuracy** of  $\pm 5\%$ .
- **Pressure/temperature measurement plugs** for verifying operating pressure differential range.

### Selection

In selecting a FlowCon K valve, the following information is needed: 1) flow rate, 2) pressure differential range and 3) pipe size.

### 1) Flow Rate Selection

In determining the flow rate, it must be decided whether the circuit will be a constant flow or modulating system.

If the valve is being fit into a constant flow system, simply select the flow rate from the Flow Rate Selection Chart (please see the catalogue: FlowCon Inserts) closest to the designed rate. If the valve is being installed in variable flow application (used in series with a modulating control valve), simply select the flow rate closest to the designed maximum flow rate of the circuit. The FlowCon K will then limit the flow to that specific maximum flow rate. Below the maximum, the valve will act as a fixed orifice device adding minimal pressure loss to the system. This allows the modulating valve to have authority up to the maximum flow rate designed for that circuit.

For applications controlling the flow of fluids other than water, the specific gravity, viscosity and operating temperature are needed for proper selection. The inserts are calibrated for water at approximately  $16^{\circ}\text{C}$ . The flow rate of a insert may be influenced by fluids with characteristics other than water (e.g. a valve calibrated for 2 l/sec used in an application with water and glycol at a concentration of 25% glycol will have an adjusted nominal flow rate of 1.969 l/sec).

For questions concerning other fluids and temperatures, please contact your FlowCon representative or one of the FlowCon offices.



## 2) Pressure Differential Range Selection

FlowCon K valves are available in four different operational pressure differential ranges, i.e. 10-95 kPaD, 22-210 kPaD, 40-390 kPaD and 90-880 kPaD. This is the pressure differential across the valve itself.

To select which range of operation is applicable for a particular circuit, determine the minimum and maximum pressure drops that the valve will experience during operation. The maximum typically occurs when the other circuits are closed, and the minimum when the other circuits are open. Then select one of the operating ranges which is wider than the range of pressure differential fluctuation calculated.

Verification of the pressure differential across the valve is possible through the optional pressure/temperature test plugs.

## 3) Size Selection

The FlowCon K valves are available in the following sizes: DN15, 20, 25, 32, 40, 50, 65 and 80. Standard FlowCon K valves are fixed female ISO threaded.

### Valve Location

The hydronic function of the valve is not affected by whether it is installed on the supply or return side of the unit. The orientation of the insert access should be considered in order to have the ability to change or clear the insert of debris if necessary. Similarly, the pressure/temperature plugs should be accessible. It is important that the flow arrow of the valve be pointing in the right direction.

## Principle of Operation

The FlowCon K valve utilizes a specific flow rate insert. Below its pressure differential range it acts as a fixed orifice (this allows a modulating valve in the same circuit to operate with valve authority up to the flow rate specified for the FlowCon K).

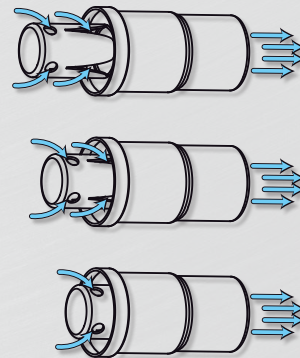

Within the operating pressure differential range, the effective open orifice area of the insert is automatically adjusted to the point where the specified flow rate will be delivered (as the pressure differential increases, the open area closes and as it decreases, the area opens).

When the pressure differential range is exceeded, the valve again becomes a fixed orifice device. This ensures that no part of the system is starved or shut down.

**Technical Data**

For further information please see FlowCon tech note and the catalogue: FlowCon Inserts.

For latest updates please see [www.flowcon.com](http://www.flowcon.com)

		K DN15	K DN20	K DN25	K DN25	K DN32	K DN40	K DN40	K DN50	K DN50	K DN65	K DN80
Static Pressure	(kPa)	2500			2500			1600		1600		
	(psi)	360			360			230		230		
Temperature Rating (media)	(°C)	-30 to +120			-30 to +120			-30 to +120		-30 to +120		
	(°F)	-22 to +248			-22 to +248			-22 to +248		-22 to +248		
Pressure Drop Data		NOTE: For pump head calculations, add the minimum pressure differential for the index circuit to the other components pressure losses (i.e. valves, coil, etc.)										
Valve	(Kv-value) (m³/hr)	5	7	10	20	30	35	52	65			
	(Cv-value) (GPM)	5.8	8.1	11.6	23.2	34.8	40.6	60.3	75.4			

Stainless Steel Insert		F360xxx	F361xxx	F3C2xxxx	F324xxxx
Size of Insert	(mm)	20mm	40mm	50mm	80mm
	(inch)	3/4"	1 1/2"	2"	3"
Pressure Differential	(kPaD)	10-880	10-880	10-880	10-880
	(psid)	1-128	1-128	1-128	1-128
Flow Rate	(l/sec)	0.021-1.01	0.189-2.78	0.757-7.19	0.883-10.10
	(GPM)	0.333-16.0	3.00-44.0	12.0-114	14.0-160



A Griswold Controls LLC./FlowCon International Company

[www.flowcon.com](http://www.flowcon.com)

D E N M A R K · D U B A I · U S A · S I N G A P O R E

# FlowCon K 15-40mm

*Automatic Balance Valve - Accessible Pre-Set Insert*



## SPECIFICATIONS

Pressure rating:	2500 kPa / 360 psi
Temperature rating, media:	-30°C to +120°C / -22°F to +248°F
Material:	
- Insert:	AISI Type 304 stainless steel
- Body:	AISI Type 17-7 PH stainless steel spring Forged brass ASTM CuZn40Pb2 or DZR brass CW602N CuZn36Pb2AS ("Enkotal <sup>®</sup> ")
- O-rings:	EPDM
End connections:	Fixed female ISO or NPT
Body tappings:	1/4" ISO
Flow rate range:	0.021-2.774 l/sec
Accessory options:	
Strainer:	20 mesh stainless steel

## DIMENSIONS AND WEIGHTS (NOMINAL) (measured in mm unless noted)

Model no.	Valve size	Insert size	L	H1	H2	Weight (kgs.)	Kv (m <sup>3</sup> /hr)
F380.x.E.x.x	15	20	89.0	61.0	74.0	0.5	5
F380.x.F.x.x	20		96.5	63.5	76.2	0.5	7
F380.x.H.x.x	25		105.0	66.0	86.4	0.5	10
F381.x.H.x.x	25	40	150.0	86.4	94.0	1.5	20
F381.x.J.x.x	32		155.0	89.0	107.0	1.5	30
F381.x.K.x.x	40		155.0	89.0	107.0	1.5	30

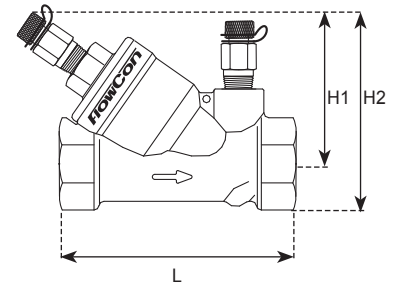

## MODEL NUMBER SELECTION<sup>1</sup>

Insert body size:  
**380**=15/20/25mm for 20mm insert  
**381**=25/32/40mm for 40mm insert

Insert kPaD control range:  
**0**=none   **1**=10-95 kPaD   **2**=22-210 kPaD   **4**=40-390 kPaD   **8**=90-880 kPaD

Insert type of end connection:  
**E**=15mm   **F**=20mm   **H**=25mm   **J**=32mm   **K**=40mm

Insert p/t plugs requirements:  
**B**=pressure/temperature plugs   **P**=taps plugged   **O**=taps open

Insert type of thread:  
 Leave it **blank** if end connection type is NPT  
**I**=ISO

Insert valve body material:  
 Leave it **blank** for standard body material  
**D**=DZR brass

Insert valve insert as per selection chart:  
 Leave it **blank** if no insert required

Example: F381.4.K.B.I.F361444=FlowCon K 40mm ISO female threaded body, standard brass, with p/t plugs and a F361444 insert (1.85 l/sec, 40-390 kPaD).

Note 1: Part number and flow rate of insert are indicated on label affixed to body.

## FLOW RATE TABLES - STAINLESS STEEL INSERT - FOR VALVES DN15-DN25 SMALL

<b>20mm · 3/4" · stainless steel insert</b>											
Nominal flow rate	Pressure range, ΔP:			10-95 kPaD 1-14 psid		22-210 kPaD 2-32 psid		40-390 kPaD 4-57 psid		90-880 kPaD 8-128 psid	
	l/sec	l/hr	GPM	Type 1		Type 2		Type 4		Type 8	
				Marking	FlowCon	Marking	FlowCon	Marking	FlowCon	Marking	FlowCon
0.0210	75.7	0.333	11-1	F360111							
0.0315	114	0.500	01-1	F360101							
0.0347	125	0.550			11-2	F360211					
0.0421	151	0.667	02-1	F360102							
0.0473	170	0.750			01-2	F360201	11-4	F360411			
0.0631	227	1.00	03-1	F360103	02-2	F360202	01-4	F360401			
0.0694	250	1.10							11-8	F360811	
0.0841	303	1.33	04-1	F360104			02-4	F360402			
0.0946	341	1.50			03-2	F360203			01-8	F360801	
0.105	379	1.67	05-1	F360105							
0.126	454	2.00	06-1	F360106	04-2	F360204	03-4	F360403	02-8	F360802	
0.147	530	2.33	07-1	F360107							
0.158	568	2.50			05-2	F360205					
0.168	606	2.67	08-1	F360108			04-4	F360404			
0.189	681	3.00			06-2	F360206			03-8	F360803	
0.210	757	3.33	10-1	F360110			05-4	F360405			
0.221	795	3.50			07-2	F360207					
0.252	908	4.00	12-1	F360112	08-2	F360208	06-4	F360406	04-8	F360804	
0.294	1060	4.67	14-1	F360114			07-4	F360407			
0.315	1140	5.00	16-1	F360116	10-2	F360210			05-8	F360805	
0.336	1210	5.33					08-4	F360408			
0.379	1360	6.00			12-2	F360212			06-8	F360806	
0.421	1511	6.67					10-4	F360410			
0.442	1590	7.00			14-2	F360214			07-8	F360807	
0.505	1820	8.00			16-2	F360216	12-4	F360412	08-8	F360808	
0.589	2120	9.33					14-4	F360414			
0.631	2270	10.0					16-4	F360416	10-8	F360810	
0.757	2730	12.0							12-8	F360812	
0.883	3180	14.0							14-8	F360814	
1.01	3630	16.0							16-8	F360816	

Accuracy: ±5% of controlled flow rate.

## FLOW RATE TABLES - STAINLESS STEEL INSERT - FOR VALVES DN25 LARGE-DN40

<b>40mm · 1 1/2" · stainless steel insert</b>											
Pressure range, ΔP:			10-95 kPaD 1-14 psid		22-210 kPaD 2-32 psid		40-390 kPaD 4-57 psid		90-880 kPaD 8-128 psid		
Nominal flow rate				Type 1		Type 2		Type 4		Type 8	
	l/sec	l/hr	GPM	Marking	FlowCon	Marking	FlowCon	Marking	FlowCon	Marking	FlowCon
0.189	681	3.00	09-1	F361109							
0.210	757	3.33	10-1	F361110							
0.252	908	4.00	12-1	F361112							
0.284	1020	4.50			09-2	F361209					
0.294	1060	4.67	14-1	F361114							
0.315	1140	5.00			10-2	F361210					
0.336	1210	5.33	16-1	F361116							
0.379	1360	6.00	18-1	F361118	12-2	F361212	09-4	F361409			
0.421	1510	6.67	20-1	F361120			10-4	F361410			
0.442	1590	7.00			14-2	F361214					
0.463	1670	7.33	22-1	F361122							
0.505	1820	8.00	24-1	F361124	16-2	F361216	12-4	F361412			
0.547	1970	8.67	26-1	F361126							
0.568	2040	9.00			18-2	F361218			09-8	F361809	
0.589	2120	9.33	28-1	F361128			14-4	F361414			
0.631	2270	10.00	30-1	F361130	20-2	F361220			10-8	F361810	
0.673	2420	10.7	32-1	F361132			16-4	F361416			
0.694	2500	11.0			22-2	F361222					
0.715	2570	11.3	34-1	F361134							
0.757	2730	12.0	36-1	F361136	24-2	F361224	18-4	F361418	12-8	F361812	
0.799	2880	12.7	38-1	F361138							
0.820	2950	13.0			26-2	F361226					
0.841	3030	13.3	40-1	F361140			20-4	F361420			
0.883	3180	14.0	42-1	F361142	28-2	F361228			14-8	F361814	
0.925	3330	14.7	44-1	F361144			22-4	F361422			
0.946	3410	15.0			30-2	F361230					
1.01	3630	16.0			32-2	F361232	24-4	F361424	16-8	F361816	
1.07	3860	17.0			34-2	F361234					
1.09	3940	17.3					26-4	F361426			
1.14	4090	18.0			36-2	F361236			18-8	F361818	
1.18	4240	18.7					28-4	F361428			
1.20	4320	19.0			38-2	F361238					
1.26	4540	20.0			40-2	F361240	30-4	F361430	20-8	F361820	
1.32	4770	21.0			42-2	F361242					
1.35	4850	21.3					32-4	F361432			
1.39	5000	22.0			44-2	F361244			22-8	F361822	
1.43	5150	22.7					34-4	F361434			
1.51	5450	24.0					36-4	F361436	24-8	F361824	
1.60	5750	25.3					38-4	F361438			
1.64	5910	26.0							26-8	F361826	
1.68	6060	26.7					40-4	F361440			
1.77	6360	28.0					42-4	F361442	28-8	F361828	
1.85	6660	29.3					44-4	F361444			
1.89	6810	30.0							30-8	F361830	
2.02	7270	32.0							32-8	F361832	
2.15	7720	34.0							34-8	F361834	
2.27	8180	36.0							36-8	F361836	
2.40	8630	38.0							38-8	F361838	
2.52	9080	40.0							40-8	F361840	
2.65	9540	42.0							42-8	F361842	
2.78	9990	44.0							44-8	F361844	

Accuracy: ±5% of controlled flow rate.

## ACCESSORIES

- P/t plugs: 2 x ACC00101
- 20 mesh strainer (ACC609000 / ACC609001)

## GENERAL SPECIFICATIONS

### 1. AUTOMATIC BALANCING VALVES - FLOWCON K

- 1.1. Contractor shall install automatic balancing valves where indicated in drawings.
- 1.2. Valve shall consist of a dynamic and accessible flow limiting device.

### 2. VALVE HOUSING

- 2.1. Valve housing shall consist of forged brass ASTM CuZn40Pb2 or DZR brass CW602N CuZn36Pb2AS (Enkotal<sup>®</sup>), rated at no less than 2500 kPa static pressure and +120°C.
- 2.2. Valve housing shall be permanently marked to show direction of flow.
- 2.3. Valve housing shall be ISO female threaded for the appropriate pipe size and shall be configured for flow regulation unit accessibility.
- 2.4. Optional dual pressure/temperature test plugs for verifying accuracy of flow performance shall be available for all valve sizes.

### 3. FLOW REGULATOR / AUTOMATIC BALANCING UNIT

- 3.1. Flow regulation unit assembly shall be manufactured of AISI type 304 stainless steel and stainless steel 17-7 spring.
- 3.2. Flow regulation unit shall be readily accessible for change-out or maintenance.
- 3.3. Flow regulation unit shall be available in 4 different kPaD operational ranges, minimum range shall be capable of being activated by minimum 10 kPaD. Further, the flow regulation unit shall be capable of controlling flow within  $\pm 5\%$  of rated flow.
- 3.4. Identification tags shall be available for all valves; tags shall be indelibly marked with part number and flow rate.

## 2-WAY APPLICATION AND SCHEMATIC EXAMPLE

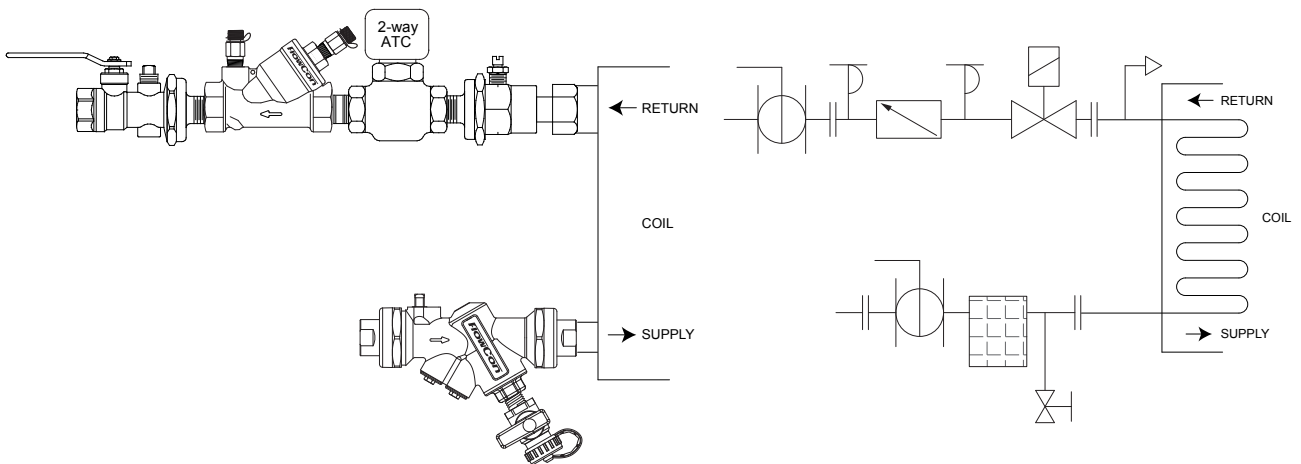

## 3-WAY APPLICATION AND SCHEMATIC EXAMPLE

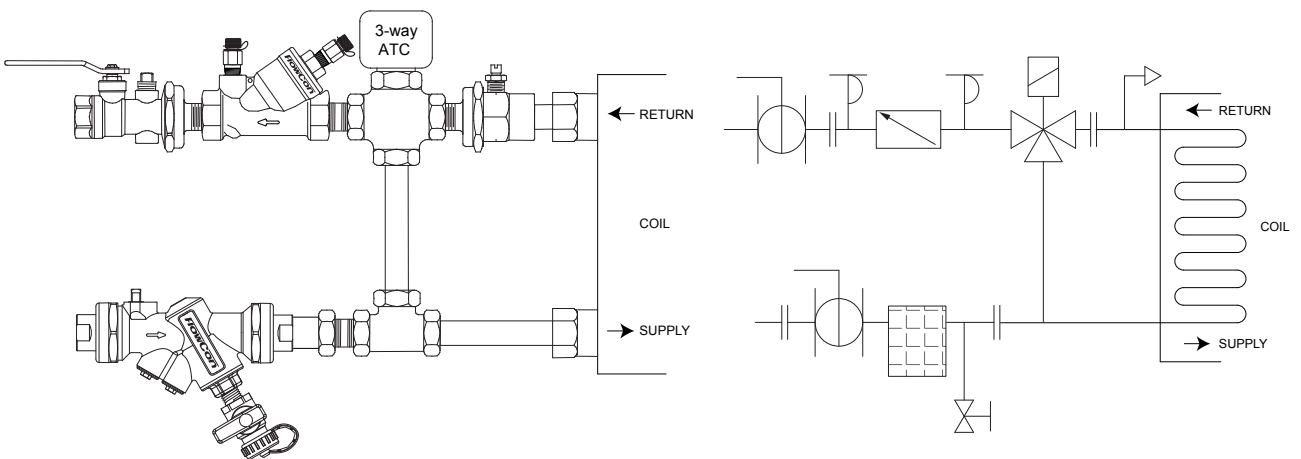

## UPDATES

For latest updates please see [www.flowcon.com](http://www.flowcon.com)

FlowCon International can accept no responsibility for possible errors in any printed material. All rights reserved.

# FlowCon K 40-80mm

*Automatic Balance Valve - Accessible Pre-Set Insert*



## SPECIFICATIONS

Pressure rating:	1600 kPa / 230 psi
Temperature rating, media:	-30°C to +120°C / -22°F to +248°F
Material:	
- Insert:	AISI Type 304 stainless steel
	AISI Type 17-7 PH stainless steel spring
- Body:	Forged brass ASTM CuZn40Pb2 or DZR brass CW602N CuZn36Pb2AS ("Enkotal <sup>®</sup> ") (DN40-DN50 small) or cast brass (DN50 large-DN80)
- O-rings:	EPDM
End connections:	F382-models: Fixed female ISO F383-models: Fixed female ISO or NPT
Body tappings:	1/4" ISO (DN40-DN50 small) 1/4" NPT (DN50 large-DN80)
Flow rate range:	0.757-10.09 l/sec

## DIMENSIONS AND WEIGHTS (NOMINAL) (measured in mm unless noted)

Model no.	Valve size	Insert size	A	B	C	Weight (kgs.)	Kv (m <sup>3</sup> /hr)
F382.x.K.x.x <sup>1</sup>	40	50	166	85	114	1.8	35
F382.x.L.x.x <sup>1</sup>	50		174	88	123	2.1	52
F383.x.L.x.x	50	80	226	69	216	4.3	65
F383.x.M.x.x	65		249				
F383.x.N.x.x	80		259				

Note 1: only ISO available

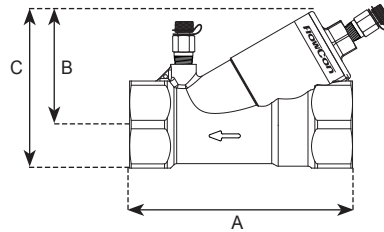

FlowCon K Model F382

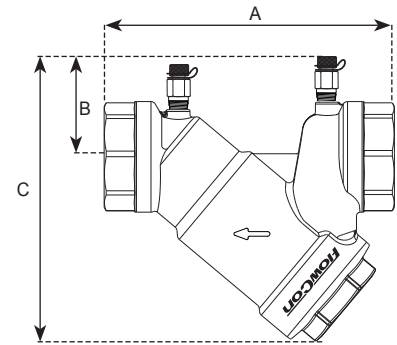

FlowCon K Model F383

## MODEL NUMBER SELECTION<sup>2</sup>

Insert body size:  
**382**=40/50mm for 50mm insert (only ISO)  
**383**=50/65/80mm for 80mm insert

Insert kPaD control range:  
**0**=none **1**=10-95 kPaD **2**=22-210 kPaD **4**=40-390 kPaD **8**=90-880 kPaD

Insert type of end connection:  
**K**=40mm **L**=50mm **M**=65mm **N**=80mm

Insert p/t plugs requirements:  
**B**=pressure/temperature plugs **P**=taps plugged **O**=taps open

Insert type of thread:  
**N**=NPT (not available for F382-models)  
**I**=ISO

Insert valve body material:  
 Leave it **blank** for standard body material  
**D**=DZR brass (DN40-DN50mm small)

Insert valve insert as per selection chart:  
 Leave it **blank** if no insert required

**F** . . . . .

Example: F382.2.K.B.I.F3C2248=FlowCon K 40mm ISO female threaded body, standard brass with p/t plugs and a F3C2248 cartridge (1.51 l/sec, 22-210 kPaD).

Note 2: Part number and flow rate of insert are indicated on label affixed to body.

## FLOW RATE TABLES - STAINLESS STEEL INSERT - FOR VALVES DN40 AND DN50 SMALL

<b>50mm · 2" · stainless steel insert</b>											
Pressure range, ΔP:			10-95 kPaD 1-14 psid		22-210 kPaD 2-32 psid		40-390 kPaD 4-57 psid		90-880 kPaD 8-128 psid		
Nominal flow rate				<b>Type 1</b>		<b>Type 2</b>		<b>Type 4</b>		<b>Type 8</b>	
	l/sec	l/hr	GPM	Marking	FlowCon	Marking	FlowCon	Marking	FlowCon	Marking	FlowCon
0.757	2730	12.0	36-1	F3C2136							
0.883	3180	14.0	42-1	F3C2142							
1.01	3630	16.0	48-1	F3C2148							
1.14	4090	18.0	54-1	F3C2154	36-2	F3C2236					
1.26	4540	20.0	60-1	F3C2160							
1.32	4770	21.0			42-2	F3C2242					
1.39	5000	22.0	66-1	F3C2166							
1.51	5450	24.0	72-1	F3C2172	48-2	F3C2248	36-4	F3C2436			
1.64	5910	26.0	78-1	F3C2178							
1.70	6130	27.0			54-2	F3C2254					
1.77	6360	28.0	84-1	F3C2184			42-4	F3C2442			
1.89	6810	30.0	90-1	F3C2190	60-2	F3C2260					
2.02	7270	32.0	96-1	F3C2196			48-4	F3C2448			
2.08	7490	33.0			66-2	F3C2266					
2.15	7720	34.0	102-1	F3C21102							
2.27	8180	36.0	108-1	F3C21108	72-2	F3C2272	54-4	F3C2454	36-8	F3C2836	
2.40	8630	38.0	114-1	F3C21114							
2.46	8860	39.0			78-2	F3C2278					
2.52	9080	40.0					60-4	F3C2460			
2.65	9540	42.0			84-2	F3C2284			42-8	F3C2842	
2.78	9990	44.0					66-4	F3C2466			
2.84	10200	45.0			90-2	F3C2290					
3.03	10900	48.0			96-2	F3C2296	72-4	F3C2472	48-8	F3C2848	
3.22	11600	51.0			102-2	F3C22102					
3.28	11800	52.0					78-4	F3C2478			
3.41	12300	54.0			108-2	F3C22108			54-8	F3C2854	
3.53	12700	56.0					84-4	F3C2484			
3.60	12900	57.0			114-2	F3C22114					
3.79	13600	60.0					90-4	F3C2490	60-8	F3C2860	
4.04	14500	64.0					96-4	F3C2496			
4.16	15000	66.0							66-8	F3C2866	
4.29	15400	68.0					102-4	F3C24102			
4.54	16400	72.0					108-4	F3C24108	72-8	F3C2872	
4.79	17300	76.0					114-4	F3C24114			
4.92	17700	78.0							78-8	F3C2878	
5.30	19100	84.0							84-8	F3C2884	
5.68	20400	90.0							90-8	F3C2890	
6.06	21800	96.0							96-8	F3C2896	
6.44	23200	102							102-8	F3C28102	
6.81	24500	108							108-8	F3C28108	
7.19	25900	114							114-8	F3C28114	

Accuracy: ±5% of controlled flow rate.

## FLOW RATE TABLES - STAINLESS STEEL INSERT - FOR VALVES DN50 LARGE-DN80

<b>80mm · 3" · stainless steel insert</b>											
Pressure range, ΔP:			10-135 kPaD 1-20 psid		22-210 kPaD 2-32 psid		40-390 kPaD 4-57 psid		90-880 kPaD 8-128 psid		
Nominal flow rate			Type 1		Type 2		Type 4		Type 8		
	l/sec	l/hr	GPM	Marking	FlowCon	Marking	FlowCon	Marking	FlowCon	Marking	FlowCon
0.883	3180	14.0	35-1	F324135							
1.01	3630	16.0	40-1	F324140							
1.10	3970	17.5			35-2	F324235					
1.14	4090	18.0	45-1	F324145							
1.26	4540	20.0	50-1	F324150	40-2	F324240					
1.39	5000	22.0	55-1	F324155							
1.42	5110	22.5			45-2	F324245					
1.47	5300	23.3					35-4	F324435			
1.51	5450	24.0	60-1	F324160							
1.58	5680	25.0			50-2	F324250					
1.64	5910	26.0	65-1	F324165							
1.68	6060	26.7					40-4	F324440			
1.73	6250	27.5			55-2	F324255					
1.77	6360	28.0	70-1	F324170							
1.89	6810	30.0	75-1	F324175	60-2	F324260	45-4	F324445			
2.02	7270	32.0	80-1	F324180							
2.05	7380	32.5			65-2	F324265					
2.10	7570	33.3					50-4	F324450			
2.15	7720	34.0	85-1	F324185							
2.21	7950	35.0			70-2	F324270			35-8	F324835	
2.27	8180	36.0	90-1	F324190							
2.31	8330	36.7					55-4	F324455			
2.37	8520	37.5			75-2	F324275					
2.40	8630	38.0	95-1	F324195							
2.52	9080	40.0	100-1	F3241100	80-2	F324280	60-4	F324460	40-8	F324840	
2.65	9540	42.0	105-1	F3241105							
2.68	9650	42.5			85-2	F324285					
2.73	9840	43.3					65-4	F324465			
2.78	9990	44.0	110-1	F3241110							
2.84	10200	45.0			90-2	F324290			45-8	F324845	
2.90	10400	46.0	115-1	F3241115							
2.94	10600	46.7					70-4	F324470			
3.00	10800	47.5			95-2	F324295					
3.03	10900	48.0	120-1	F3241120							
3.15	11400	50.0	125-1	F3241125	100-2	F3242100	75-4	F324475	50-8	F324850	
3.28	11800	52.0	130-1	F3241130							
3.31	11900	52.5			105-2	F3242105					
3.36	12100	53.3					80-4	F324480			
3.41	12300	54.0	135-1	F3241135							
3.47	12500	55.0			110-2	F3242110			55-8	F324855	
3.53	12700	56.0	140-1	F3241140							
3.58	12900	56.7					85-4	F324485			
3.63	13100	57.5			115-2	F3242115					
3.66	13200	58.0	145-1	F3241145							
3.79	13600	60.0	150-1	F3241150	120-2	F3242120	90-4	F324490	60-8	F324860	
3.94	14200	62.5			125-2	F3242125					
4.00	14400	63.3					95-4	F324495			
4.10	14800	65.0			130-2	F3242130			65-8	F324865	
4.21	15100	66.7					100-4	F3244100			
4.26	15300	67.5			135-2	F3242135					
4.42	15900	70.0			140-2	F3242140	105-4	F3244105	70-8	F324870	
4.57	16500	72.5			145-2	F3242145					
4.63	16700	73.3					110-4	F3244110			
4.73	17000	75.0			150-2	F3242150			75-8	F324875	
4.84	17400	76.7					115-4	F3244115			
5.05	18200	80.0					120-4	F3244120	80-8	F324880	
5.26	18900	83.3					125-4	F3244125			
5.36	19300	85.0							85-8	F324885	
5.47	19700	86.7					130-4	F3244130			
5.68	20400	90.0	220-1	F3241220*			135-4	F3244135	90-8	F324890	
5.89	21200	93.3					140-4	F3244140			
5.99	21600	95.0							95-8	F324895	
6.10	22000	96.7					145-4	F3244145			
6.31	22700	100					150-4	F3244150	100-8	F3248100	
6.62	23800	105							105-8	F3248105	
6.94	25000	110	270-1	F3241270*	220-2	F3242220**			110-8	F3248110	
7.26	26100	115							115-8	F3248115	
7.57	27300	120							120-8	F3248120	
7.89	28400	125							125-8	F3248125	
8.20	29500	130	320-1	F3241320*					130-8	F3248130	
8.52	30711	135			270-2	F3242270**			135-8	F3248135	
8.83	31800	140							140-8	F3248140	
9.15	32900	145							145-8	F3248145	
9.46	34100	150							150-8	F3248150	
10.10	36300	160			320-2	F3242320**					

Accuracy: ±5% of controlled flow rate.

\* Standard flow, high capacity: the pressure range for these flow rates is 28-135 kPaD  
 \*\* Standard flow, high capacity: the pressure range for these flow rates is 55-210 kPaD.

## GENERAL SPECIFICATIONS

### 1. AUTOMATIC BALANCING VALVES - FLOWCON K

- 1.1. Contractor shall install automatic balancing valves where indicated in drawings.
- 1.2. Valve shall consist of a dynamic and accessible flow limiting device.

### 2. VALVE HOUSING

- 2.1. Valve housing shall consist of forged brass ASTM (CuZn40Pb2) or DZR brass CW602N CuZn6Pb2AS ("Enkotal<sup>®</sup>") (FlowCon K DN40-DN50 small) or cast brass (FlowCon K DN50 large-DN80) and be rated at no less than 1600 kPa static pressure and +120°C.
- 2.2. Valve housing shall be permanently marked to show direction of flow.
- 2.3. Valve housing shall be ISO female threaded for the appropriate pipe size and shall be configured for accessibility.
- 2.4. Optional dual pressure/temperature test plugs for verifying accuracy of flow performance shall be available for all valve sizes.
- 2.5. Housing shall be configured for flow regulation unit accessibility.

### 3. FLOW REGULATOR / AUTOMATIC BALANCING UNIT

- 3.1. Flow regulation unit assembly shall be manufactured of AISI type 304 stainless steel, and stainless steel 17-7 spring.
- 3.2. Flow regulation unit shall be readily accessible for change-out or maintenance.
- 3.3. Flow regulation unit shall be available in 4 different kPaD operational ranges, minimum range shall be capable of being activated by minimum 10 kPaD. Further, the flow regulation unit shall be capable of controlling flow within  $\pm 5\%$  of rated flow.
- 3.4. Identification tags shall be available for all valves; tags shall be indelibly marked with part number and flow rate.

## 2-WAY APPLICATION AND SCHEMATIC EXAMPLE

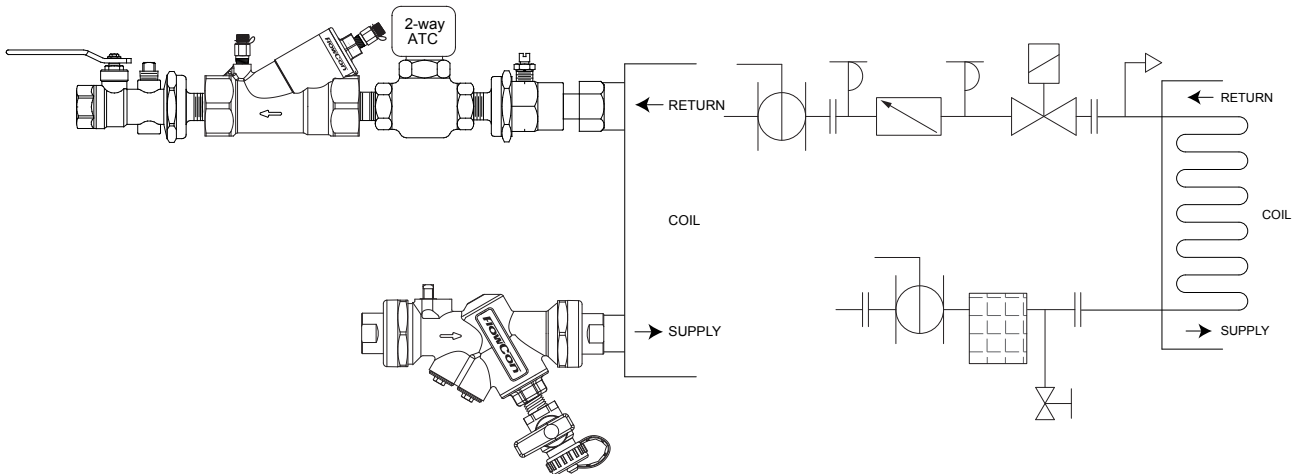

## 3-WAY APPLICATION AND SCHEMATIC EXAMPLE

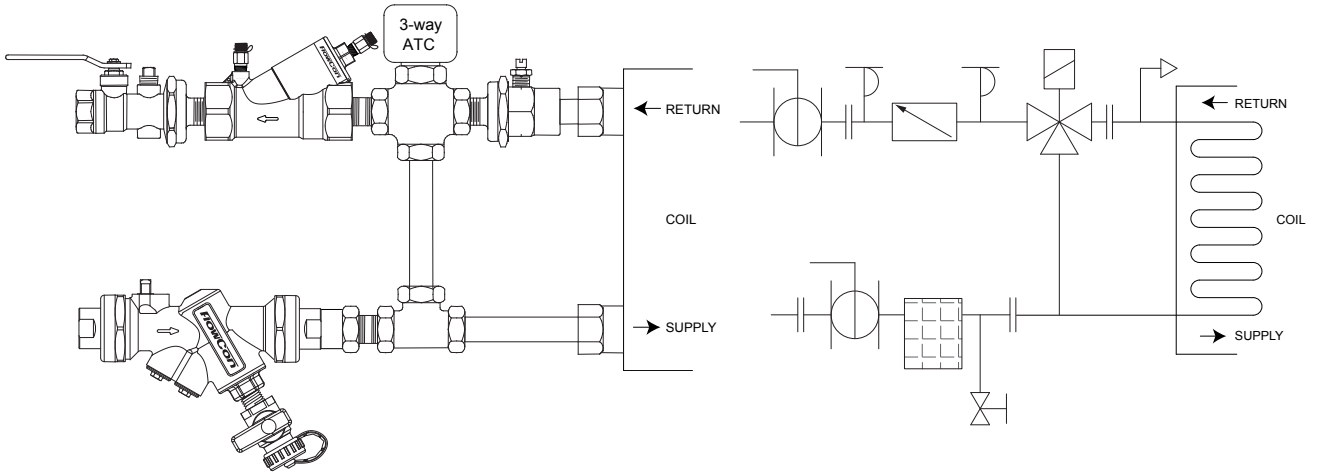

## UPDATES

For latest updates please see [www.flowcon.com](http://www.flowcon.com)

FlowCon International can accept no responsibility for possible errors in any printed material.  
All rights reserved.

# FlowCon Pure 316 Stainless Steel 40-50mm

*Automatic Balancing Valve – Pre-Set Built-In Flow-Limiter*



## SPECIFICATIONS

Pressure rating:	3000 kPa at +20°C / 435 psi at +68°F
Temperature rating, media:	0°C to +200°C / +32°F to +392°F +200°C at 660 kPa or lower / +392°F at 95.7 psi or lower
Material:	
- Body:	AISI 316L stainless steel 0.8 $\mu$ Ra/ISO N6/150 Grit on outer surfaces 0.4 $\mu$ Ra/ISO N5/240 Grit on inner surfaces
- Shims:	EN 1.4404, corresponding to AISI 316L stainless steel
- Spring:	EN 1.4401, corresponding to AISI 316 stainless steel
- Cup:	AISI 316L stainless steel
- Orifice:	AISI 316L stainless steel
- Lock ring:	EN 1.4462, corresponding to AISI 318LN stainless steel
Pressure range:	100-800 kPaD / 14.5-116 psid
End connections:	Clamp Ferrules sizes: 1 1/2" and 2", fittable for Tri-Clover connections Clamps and gaskets are not supplied by FlowCon

## DIMENSIONS AND WEIGHTS (NOMINAL) (measured in mm unless noted)

Model no.	End connection <sup>1</sup>	D1 (mm)	D2 (mm)	L (mm)	Weight <sup>2</sup> (kgs.)
F494.8.1.xx	1½" clamp ferrules	38.1	50.6	68.0	0.6
F494.8.2.xx	2" clamp ferrules	50.8	63.5	110.0	1.3

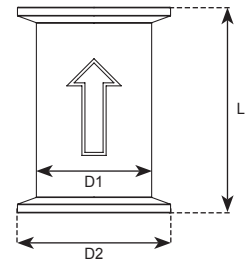

Note 1: Fittable for Tri-Clover connections.  
 Note 2: Nominal weight, including inserts and packing material, exact weight is dependent on inserts.

## MODEL NUMBER SELECTION

**F494 . 8 . . . . .**

Insert pressure range type:  
**8** = 100-800kPaD \_\_\_\_\_

Insert size:  
**1** = 1½" \_\_\_\_\_  
**2** = 2" \_\_\_\_\_

Insert flow #:  
 According to flow rate table below \_\_\_\_\_

Example: F494.8.1.06=Mini-Wafer for 1 1/2" clamps with flow rate of 0.493 l/sec.

## FLOW RATE GRAPH (accuracy: ±10% of controlled flow rate).

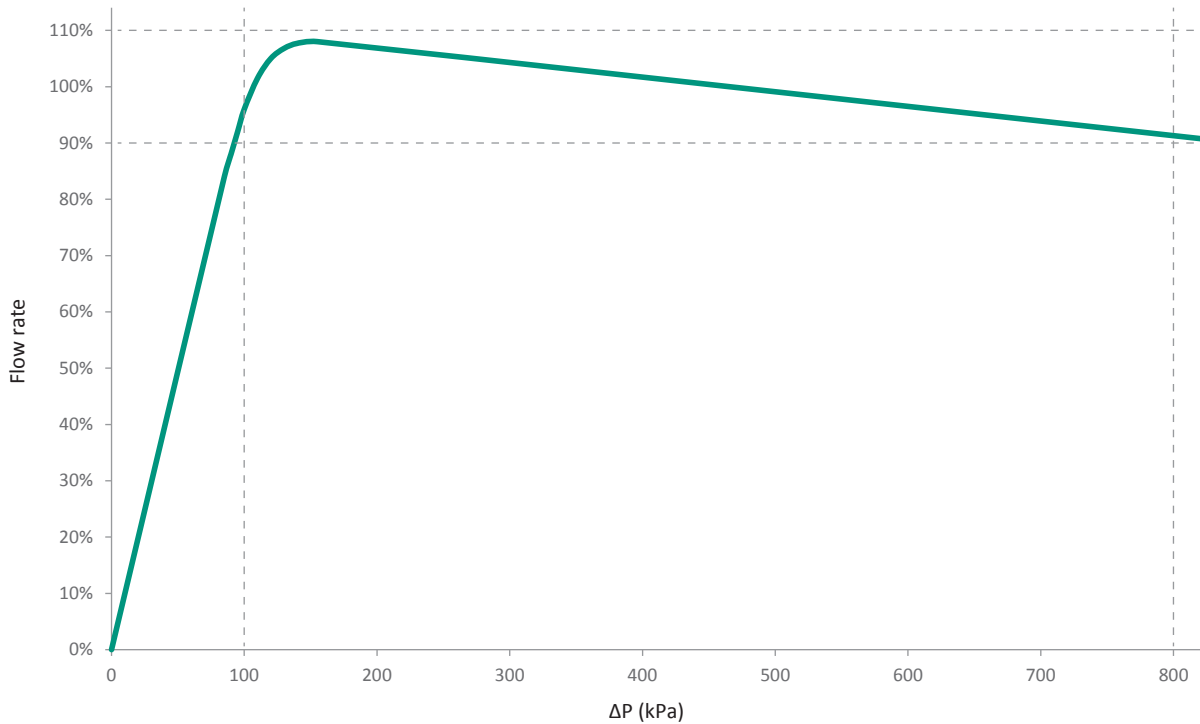

## FLOW RATE TABLE - STAINLESS STEEL INTERNAL PART - FOR 1 1/2" VALVES

20mm · 3/4" · Stainless Steel Internal Parts - for 1 1/2" valves			
Flow #	Flow (GPM)	Flow (l/hr)	Flow (l/sec)
11	3.30	750	0.208
01	3.90	887	0.246
02	4.40	1000	0.277
03	5.40	1230	0.340
04	6.40	1450	0.403
05	7.00	1600	0.441
06	7.80	1770	0.493
07	8.75	1990	0.553
08	9.60	2180	0.606
10	11.5	2610	0.726
12	13.2	3000	0.833
14	15.1	3430	0.954
16	16.8	3810	1.06

Accuracy: ±10% of controlled flow rate.

## FLOW RATE TABLE - STAINLESS STEEL INTERNAL PART - FOR 2" VALVES

40mm · 1 1/2" · Stainless Steel Internal Parts - for 2" valves			
Flow #	Flow (GPM)	Flow (l/hr)	Flow (l/sec)
09	12.4	2800	0.780
10	13.6	3090	0.859
12	16.1	3660	1.02
14	18.5	4200	1.17
16	20.8	4720	1.31
18	23.0	5240	1.46
20	25.2	5730	1.59
22	27.4	6220	1.73
24	29.4	6690	1.85
26	31.5	7170	1.99
28	33.5	7600	2.12
30	35.5	8060	2.24
32	37.6	8540	2.37
34	39.6	8990	2.50
36	41.7	9460	2.63
38	43.7	9920	2.76
40	45.8	10400	2.89
42	47.8	10900	3.02
44	49.8	11300	3.15

Accuracy: ±10% of controlled flow rate.

## GENERAL SPECIFICATIONS

1. **AUTOMATIC BALANCING VALVES – FLOWCON MINI-WAFER**
  - 1.1. Contractor shall install automatic balancing valves where indicated in drawings.
  - 1.2. Valve shall consist of a dynamic, flow limiting device.
2. **VALVE**
  - 2.1. Valve shall consist of AISI 316/316L/318LN or equivalent EN Stainless Steel.
  - 2.2. Valve housing shall be rated at no less than 3000 kPa (435 psi) static pressure and +200°C (+392°F), but within the below graph.
  - 2.3. Valve housing shall be permanently marked to show direction of flow.
  - 2.4. Valve housing shall be compatible with Tri-Clover Clamps.
3. **FLOW REGULATOR / AUTOMATIC BALANCING UNIT**
  - 3.1. Flow regulation shall be available in 1 kPaD operational range and minimum range shall be capable of being activated by minimum 100 kPaD. The flow regulation shall be capable of controlling flow within  $\pm 10\%$  of rated flow.
  - 3.2. Indication tags shall be available for all valves; tags shall be indelibly marked with part number and flow rate.

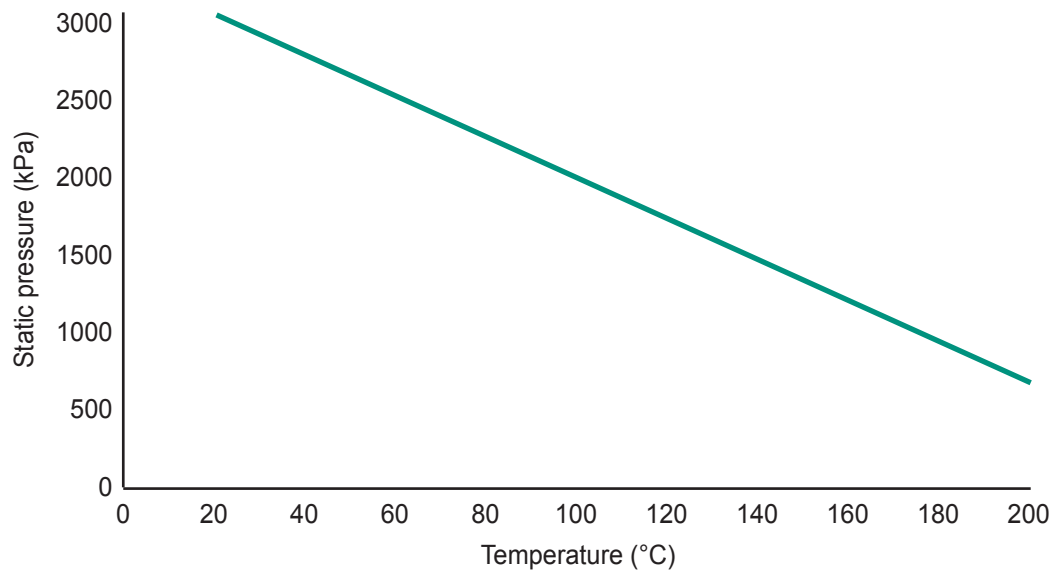

## UPDATES

For latest updates please see [www.flowcon.com](http://www.flowcon.com)

FlowCon International can accept no responsibility for possible errors in any printed material.  
All rights reserved.

# FlowCon High Flow

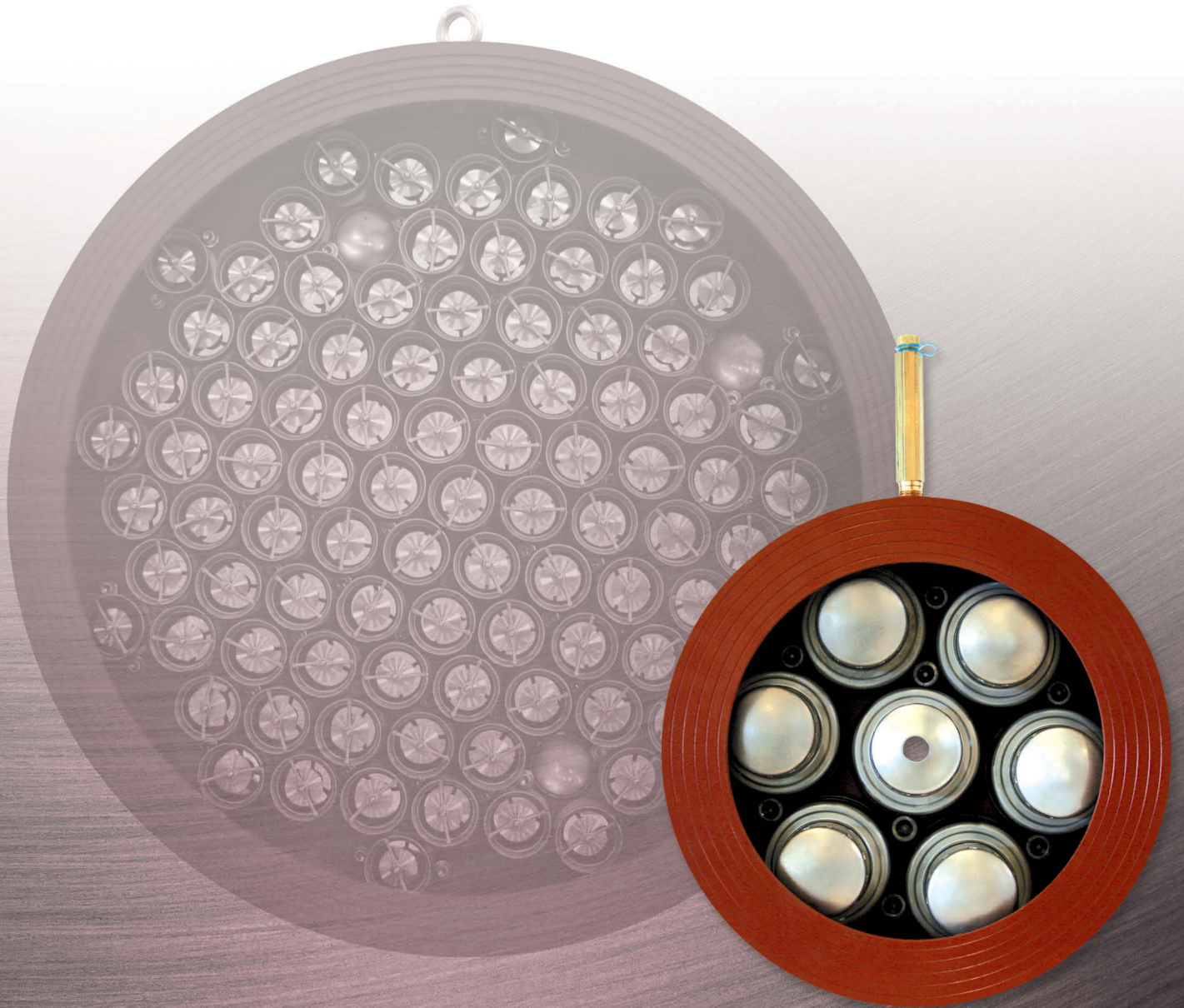

*The High Flow Valve Series*

# FlowCon High Flow

*Automatic, Dynamic Balancing Valves*



The FlowCon high flow series of valves are designed to meet the higher capacity flow limiting requirements of pumps, chillers, boilers, condensers, heat exchangers, cooling towers and filters.

## **Product Range**

The high flow series cover Uni-Flange, AHU-Wafer, Wafer and Grooved End. Applications are many and each product covers several different ones from air handling units and boiler flow control in common HVAC systems over multiple chillers / multiple heat exchangers or pump balancing system in high-rise buildings to fueling, industrial process and filtration applications.

## **Features and Benefits**

- **Automatic balancing**, the correct flow rate for each circuit is achieved automatically.
- **Dynamic balancing**, the correct flow rate is maintained as each valve compensates for pressure fluctuations in the system.
- **Pre-set stainless steel insert(s)** with few moving parts, ensure high reliability.
- **Accuracy** of  $\pm 5\%$ .
- **Wide range of sizes and flow rates**, max. 1000mm and 2286.9 l/sec.
- **Pressure / temperature measurements plugs** for verifying operating pressure differential range.

## **Principle of Operation**

The FlowCon high flow valves utilize precision calibrated stainless steel flow rate inserts to achieve the desired flow rate. Each insert is manufactured to deliver a specific flow rate over a wide operating range of differential pressures at a tolerance of  $\pm 5\%$ . This is done by automatically adjusting the open orifice area of the insert in reaction to change in pressure.

High flow valves requiring more flow than achieved by a single insert, utilize multiple inserts mounted in parallel into webbing within the valve body. The sum of the flow rates of the inserts within any valve equals the total flow rate for the valve. For instance a 150mm (6") wafer containing four inserts, i.e. two at 4.00 l/sec and two at 5.05 l/sec, will have a total flow rate of 18.1 l/sec.

As shown in the picture on next page, the insert is simply a fixed orifice device below its pressure differential range. This allows a modulating valve in the same circuit to operate with valve authority up to the flow rate specified.

Once in the pressure differential range, the spring mounted cup of the insert actually slides within the insert housing adjusting the effective open orifice area of the insert to the exact point, where the specified flow rate will be delivered. As the pressure differential across the valve increases, the orifice area closes; as it decreases, the orifice area opens. In multi-insert valves, all inserts will operate simultaneously.

When the pressure differential range is exceeded, the valve again becomes a fixed orifice device. This ensures that, even under extreme conditions, no part of the system is starved or shut down.

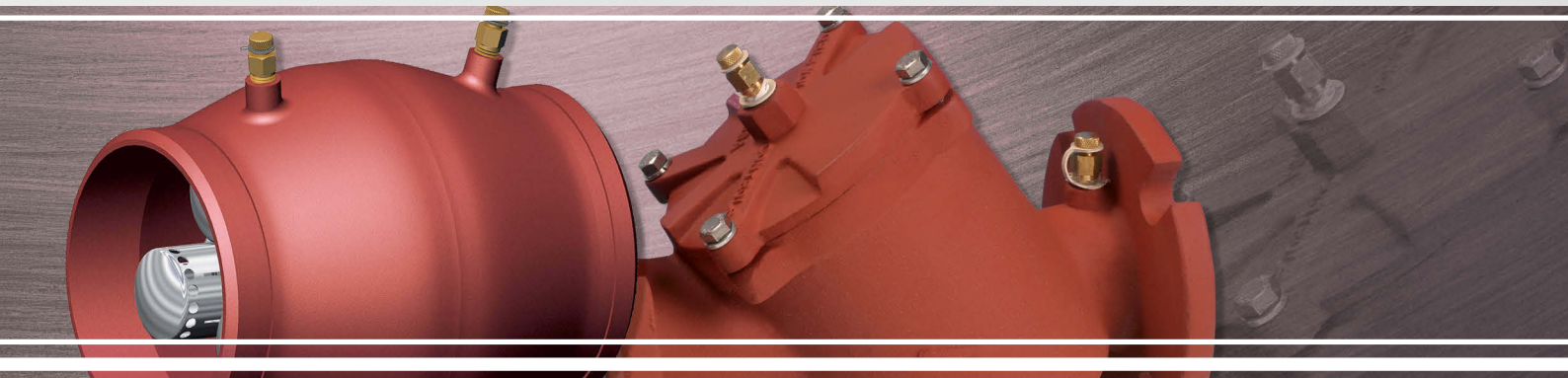

## Selection

In selecting a FlowCon high flow valve, the following information is needed: 1) flow rate, 2) pressure differential range and 3) pipe size.

### 1) Flow Rate Selection

In determining the flow rate, it must be decided whether the circuit will be a constant flow or modulating system.

If the valve is being fit into a constant flow system, simply select the flow rate from the Flow Rate Selection Chart (see FlowCon tech notes or the Inserts Catalogue) closest to the designed rate. If the valve is being installed in a variable flow application (used in series with a modulating control valve), simply select the flow rate closest to the designed maximum flow rate of the circuit. The FlowCon high flow valve will then limit the flow to that specific maximum rate. Below the maximum, the valve will add minimal pressure loss to the system. This allows the modulating valve to have authority up to the maximum flow rate designed for that circuit.

For applications controlling the flow of fluids other than water, the specific gravity, viscosity and operating temperature are needed for proper selection. The flow rate inserts are calibrated for water at approximately 16°C. For questions concerning other fluids and temperatures, please contact your FlowCon representative or one of the FlowCon offices.

### 2) Pressure Differential Range Selection

The high flow valves are available in four different operational pressure differential ranges, 10-135 kPaD, 22-210 kPaD, 40-390 kPaD and 90-880 kPaD. This is the pressure differential across the valve itself.

To select which range of operation is applicable for a particular circuit, determine the minimum and maximum pressure drops that the valve will experience during operation. The maximum typically occurs when the other circuits are closed, and the minimum when the other circuits are open. Then select one of the operating ranges which is wider than the range of pressure differential fluctuation calculated. In most heating and air conditioning systems either 22-210 kPaD or 40-390 kPaD are sufficient.

Verification of the temperature, pressure and pressure differential across the valve is possible through the pressure / temperature test plugs.

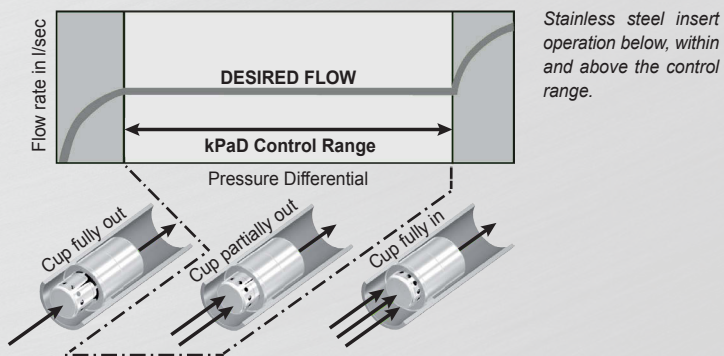

*Stainless steel insert operation below, within and above the control range.*

*Below the control range, the insert acts as a variable flow device allowing flow to vary below the rated amount.*

*Within the wide control range, the insert modulates in response to change in pressure to maintain a fixed flow rate within  $\pm 5\%$  accuracy.*

*Above the control range, the insert acts as a variable flow device, allowing flow to vary above the rated amount.*

### 3) Size Selection

The FlowCon high flow valves are available in sizes from DN50 to DN1000 depending on type. All high flow types are for use with either flanges or grooved end clamps. The size of the valve in some applications may be dependent on the flow rate required. If a FlowCon valve larger than the system pipe size is selected, a reducing flange are required.

### Valve Location

The hydronic function of the valve is not affected by whether it is installed on the supply or return side of the unit, and the valves may be installed either horizontally or vertically. It is, however, important that the flow arrow of the valve be pointing in the flow direction. Flow in the "wrong" direction will not be controlled. The orientation of valve should allow for access to the test plugs. Extensions are available for use in insulated applications.

### Applications

Energy efficient heating and cooling systems require accurate flow control to ensure proper operation of primary plant equipment. The FlowCon high flow valves have been specifically designed to control flow and solve balancing problems in such large hydronic systems. Under typical conditions in such a system, pressures may vary by 350 kPa to 700 kPa as pumps are switched on or circuits are isolated. A dynamic reacting valve is required to safeguard equipment and ensure that flow through every active circuit remains constant and predictable.

### Technical Data

For further information please see FlowCon tech notes. For latest updates please see [www.flowcon.com](http://www.flowcon.com)

	Wafer DN100-1000	Uni-Flange DN65-80	AHU-Wafer DN50-80	Grooved End DN50-500
Static Pressure (kPa)	3400	1030	2500	2500
	(psi)	493	149	360
Temperature Rating (°C)	+175	+135	+135	+95
	(media) (°F)	+347	+275	+275
Pressure Drop Data	NOTE: For pump head calculations, add the minimum pressure differential for the index circuit to the other components pressure losses (i.e. valves, coil, etc.)			
Valve	Kv-value	105	N/A	N/A
	Cv-value	N/A	121.8	N/A
Stainless Steel Insert	F324xxxx	F3C2xxxx	F324xxxx	F324xxxx
Insert Size (mm)	80	50	80	80
	(inch)	3	2	3
Pressure (kPaD)	10-880	10-880	10-880	10-880
Differential (psid)	1-128	1-128	1-128	1-128
Flow Rate (l/sec)	0.883-2286.9	0.757-21.6	0.883-10.1	0.883-642.6
	(GPM)	14.0-36300	12.0-342	14.0-160
			14.0-10200	

### Condenser Systems

Proper flow rate to a cooling tower is essential for adequate removal of heat from the condenser section of a chiller. Use of dynamic valves maintains even distribution to each condenser and prevents cooling tower flooding.

### Primary / Secondary Systems

Primary chillers and pumps are usually designed in parallel to allow equipment staging. This arrangement allows chillers to come on-line only when required during peak cooling hours, thus conserve energy. A FlowCon high flow valve placed at each chiller prevents excess flow caused by over pumping during light load conditions. Installing dynamic balancing valves also protects equipment warranties as flow rates are assured to be in the range specified by the manufacturer. Varying pressures caused by opening and closing of modulating valves are accurately compensated for by the modulating action of the FlowCon high flow valves.

### Parallel Pumping

In systems with pumps in parallel, the use of a dynamic balancing valve is essential as the slightest difference in pump characteristics will result in one pump overload and system inefficiency. Dissimilar or different sized pumps accentuate this problem. The FlowCon high flow valves will ensure that the pump is operating at the designed point of its curve by adding the required amount of pressure loss to achieve the designed flow rate.



A Griswold Controls LLC./FlowCon International Company

[www.flowcon.com](http://www.flowcon.com)

D E N M A R K . D U B A I . U S A . S I N G A P O R E

# FlowCon AHU-Wafer 50-80mm

*Automatic Balancing Valve - Pre-Set Insert*



## SPECIFICATIONS

Pressure rating:	2500 kPa / 360 psi
Temperature rating, media:	-20°C to +135°C / -4°F to +275°F
Material:	
- Insert:	AISI type 304 stainless steel AISI type 17-7 PH stainless steel spring
- Body tappings:	1/4" NPT
- Body:	Ductile iron ASTM A536, class 60-40-18/EN-GJS-400-18
- O-rings:	EPDM
- Retaining clip:	AISI type 302 stainless steel
End connections:	DIN flanges according to EN1092-1, PN10+ Size 2": ANSI B 16.5 300lb class flanges Size 2 1/2"-3": ANSI B 16.5 150lb class flanges Flanges are not supplied by FlowCon. Studs and nuts are available upon request
Flow rate range:	0.883-10.10 l/sec

## DIMENSIONS AND WEIGHTS (NOMINAL) (measured in mm unless noted)

Model no.	Valve size (mm)	Valve size (")	Insert size	Flanges <sup>1</sup>				L	D1	D2	H	Weight (kgs.)
				ANSI ASME B16.5		EN 1092-1						
				Class	D3 (")	PN	D3 (mm)					
F386.x.L.B	50	2	80	300 and up	6 1/2	10 and up	165	174.5	81.5	107.0	140.0	4.4
F386.x.M.B	65	2 1/2		150 and up	7	10 and up	185			117.5	144.0	6.5
	80	3		150 and up	7 1/2	10 and up	200					

Note 1: Smallest pressure class weld neck flange fitting.

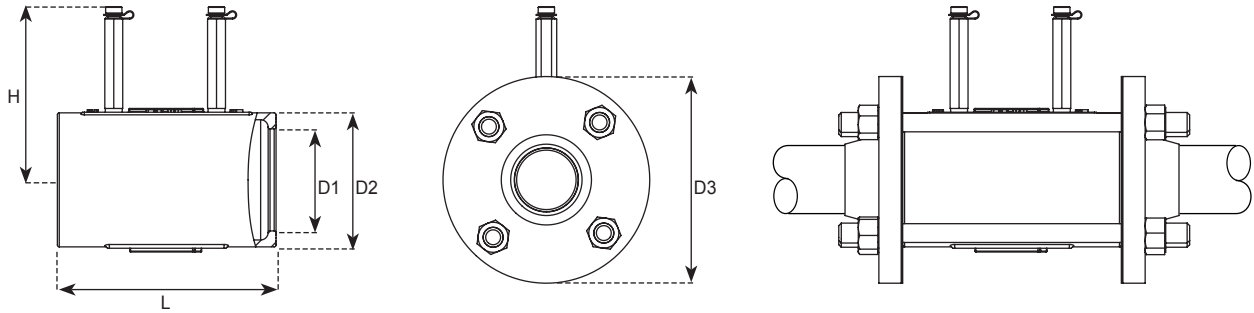

## MODEL NUMBER SELECTION

Insert a kPaD control range:

**0**=None **1**=10-135 kPaD **2**=22-210 kPaD **4**=40-390 kPaD **8**=90-880 kPaD

Insert body size:

**L**=50mm **M**=65/80mm

Insert p/t plug requirement:

**B**=Pressure/temperature plugs (standard)

Example: F386.0.M.B=AHU Wafer for 65/80mm flanges with p/t plugs and no insert.

**Note: Please specify flow requirements as per selection chart when ordering with insert.**

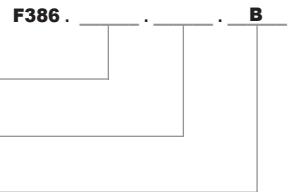

## FLOW RATE TABLE

80mm · 3" · stainless steel insert											
Pressure range, ΔP:			10-135 kPaD 1-20 psid		22-210 kPaD 2-32 psid		40-390 kPaD 4-57 psid		90-880 kPaD 8-128 psid		
l/sec	l/hr	GPM	Type 1		Type 2		Type 4		Type 8		
			Marking	FlowCon	Marking	FlowCon	Marking	FlowCon	Marking	FlowCon	
0.883	3180	14.0	35-1	F324135							
1.01	3630	16.0	40-1	F324140							
1.10	3970	17.5			35-2	F324235					
1.14	4090	18.0	45-1	F324145							
1.26	4540	20.0	50-1	F324150	40-2	F324240					
1.39	5000	22.0	55-1	F324155							
1.42	5110	22.5			45-2	F324245					
1.47	5300	23.3					35-4	F324435			
1.51	5450	24.0	60-1	F324160							
1.58	5680	25.0			50-2	F324250					
1.64	5910	26.0	65-1	F324165							
1.68	6060	26.7					40-4	F324440			
1.73	6250	27.5			55-2	F324255					
1.77	6360	28.0	70-1	F324170							
1.89	6810	30.0	75-1	F324175	60-2	F324260	45-4	F324445			
2.02	7270	32.0	80-1	F324180							
2.05	7380	32.5			65-2	F324265					
2.10	7570	33.3					50-4	F324450			
2.15	7720	34.0	85-1	F324185							
2.21	7950	35.0			70-2	F324270			35-8	F324835	
2.27	8180	36.0	90-1	F324190							
2.31	8330	36.7					55-4	F324455			
2.37	8520	37.5			75-2	F324275					
2.40	8630	38.0	95-1	F324195							
2.52	9080	40.0	100-1	F3241100	80-2	F324280	60-4	F324460	40-8	F324840	
2.65	9540	42.0	105-1	F3241105							
2.68	9650	42.5			85-2	F324285					
2.73	9840	43.3					65-4	F324465			
2.78	9990	44.0	110-1	F3241110							
2.84	10200	45.0			90-2	F324290			45-8	F324845	
2.90	10400	46.0	115-1	F3241115							
2.94	10600	46.7					70-4	F324470			
3.00	10800	47.5			95-2	F324295					
3.03	10900	48.0	120-1	F3241120							
3.15	11400	50.0	125-1	F3241125	100-2	F3242100	75-4	F324475	50-8	F324850	
3.28	11800	52.0	130-1	F3241130							
3.31	11900	52.5			105-2	F3242105					
3.36	12100	53.3					80-4	F324480			
3.41	12300	54.0	135-1	F3241135							
3.47	12500	55.0			110-2	F3242110			55-8	F324855	
3.53	12700	56.0	140-1	F3241140							
3.58	12900	56.7					85-4	F324485			
3.63	13100	57.5			115-2	F3242115					
3.66	13200	58.0	145-1	F3241145							
3.79	13600	60.0	150-1	F3241150	120-2	F3242120	90-4	F324490	60-8	F324860	
3.94	14200	62.5			125-2	F3242125					
4.00	14400	63.3					95-4	F324495			
4.10	14800	65.0			130-2	F3242130			65-8	F324865	
4.21	15100	66.7					100-4	F3244100			
4.26	15300	67.5			135-2	F3242135					
4.42	15900	70.0			140-2	F3242140	105-4	F3244105	70-8	F324870	
4.57	16500	72.5			145-2	F3242145					
4.63	16700	73.3					110-4	F3244110			
4.73	17000	75.0			150-2	F3242150			75-8	F324875	
4.84	17400	76.7					115-4	F3244115			
5.05	18200	80.0					120-4	F3244120	80-8	F324880	
5.26	18900	83.3					125-4	F3244125			
5.36	19300	85.0							85-8	F324885	
5.47	19700	86.7					130-4	F3244130			
5.68	20400	90.0	220-1	F3241220*			135-4	F3244135	90-8	F324890	
5.89	21200	93.3					140-4	F3244140			
5.99	21600	95.0							95-8	F324895	
6.10	22000	96.7					145-4	F3244145			
6.31	22700	100					150-4	F3244150	100-8	F3248100	
6.62	23800	105							105-8	F3248105	
6.94	25000	110	270-1	F3241270*	220-2	F3242220**			110-8	F3248110	
7.26	26100	115							115-8	F3248115	
7.57	27300	120							120-8	F3248120	
7.89	28400	125							125-8	F3248125	
8.20	29500	130	320-1	F3241320*					130-8	F3248130	
8.52	30700	135			270-2	F3242270**			135-8	F3248135	
8.83	31800	140							140-8	F3248140	
9.15	32900	145							145-8	F3248145	
9.46	34100	150							150-8	F3248150	
10.10	36300	160			320-2	F3242320**					

Accuracy: ±5% of controlled flow rate.

\* Standard flow, high capacity: the pressure range for these flow rates is 28-135 kPaD (4-20 psid).  
 \*\* Standard flow, high capacity: the pressure range for these flow rates is 55-210 kPaD (8-32 psid).

## GENERAL SPECIFICATIONS

- 1. AUTOMATIC BALANCING VALVES - FLOWCON AHU-WAFER**
  - 1.1. Contractor shall install automatic balancing valves where indicated in drawings.
  - 1.2. Valve shall consist of a dynamic, flow limiting device.
  
- 2. VALVE HOUSING**
  - 2.1. Valve housing shall consist of ductile iron ASTM A536-80, class 60-40-18, rated at no less than 2500 kPa static pressure and +135°C.
  - 2.2. Valve housing shall be permanently marked to show direction of flow.
  - 2.3. Dual pressure/temperature test plugs for verifying accuracy of flow performance shall be provided for all valve sizes.
  - 2.4. Valve housing shall be compatible with ANSI B 16.5 150 lb/300 lb steel flanges (depending on size) and be compatible to DIN PN10+ flanges according to EN1092-1.
  
- 3. FLOW REGULATOR / AUTOMATIC BALANCING UNIT**
  - 3.1. Flow regulation unit assembly shall be manufactured of AISI type 304 stainless steel and stainless steel 17-7 spring.
  - 3.2. Flow regulation unit shall be available in 4 different kPaD operational range; minimum range shall be capable of being activated by minimum 10 kPaD. Further, the flow regulation unit shall be capable of controlling flow within  $\pm 5\%$  of rated flow.
  - 3.3. Identification tags shall be available for all valves; tags shall be indelibly marked with part number and flow rate.

## UPDATES

**For latest updates please see [www.flowcon.com](http://www.flowcon.com)**

FlowCon International can accept no responsibility for possible errors in any printed material.  
All rights reserved.

# FlowCon Wafer 100-1000mm

*Automatic Balancing Valve - Pre-Set Insert(s)*



## SPECIFICATIONS

Pressure rating:	3400 kPa / 493 psi
Temperature rating, media:	-20°C to +175°C / -4°F to +347°F
Material:	
- Insert:	AISI Type 304 stainless steel
	AISI Type 17-7 PH stainless steel spring
- Body:	Ductile iron ASTM A536, class 60-40-18/EN-GJS-400-18
Body tappings:	1/4" NPT
End connections:	Sizes: 100-250mm and 350-1000mm: EN1092-1, PN25+ 300mm: EN1092-1, PN40+ 4"-8" and 12"-18": ANSI B 16.5 150lb class flanges+ 10" and 20"-24": ANSI B 16.5 300lb class flanges+ 30": ANSI B 16.47 300lb class flanges+ 32"-40": ANSI B 16.47 150lb class flanges+ Flanges are not supplied by FlowCon Studs and nuts are available upon request
Flow rate range:	0.883-2286.9 l/sec

## DIMENSIONS AND WEIGHTS (NOMINAL) (measured in mm unless noted)

Model no.	D1 (mm)	D1 (")	D2 (±1%)	Insert size	Flanges <sup>1</sup>				L (±1%)	H	Weight <sup>2</sup> (kgs.)	Max no. of inserts per wafer
					ANSI ASME B16.5		EN 1092-1					
					Class	D3 (")	PN	D3 (mm)				
F332x	100	4	172.00	80	150 and up	9	25 and up <sup>3</sup>	235	197.00	90	15	2 <sup>4</sup>
F334x	150	6	218.95		150 and up	11	10 and up	285	184.15	90	19	4
F337x	200	8	276.35		150 and up	13,5	25 and up	360	184.15	90	26	7
F368x	250	10	341.38		300 and up	17,5	25 and up	425	203.20	90	36	11
F369x	300	12	406.40		150 and up	19	40 and up	515	203.20	90	61	15
F339x	350	14	447.80		150 and up	21	25 and up	555	203.20	90	69	19
F384x	400	16	511.05		150 and up	23,5	25 and up	620	241.30	90	102	24
F385x	450 <sup>5</sup>	18 <sup>5</sup>	546.10		150 and up	25	16 and up	640	241.30	90	114	31
F338x	500 <sup>5</sup>	20 <sup>5</sup>	606.55		300 and up	30,5	16 and up	715	279.40	90	163	37
F386x	600 <sup>5</sup>	24 <sup>5</sup>	714.25		300 and up	36	16 and up	840	279.40	90	217	55
F330x	800 <sup>5</sup>	30 <sup>5</sup>	882.65		300 and up <sup>6</sup>	43	10 and up	1015	431.80	90	401	85
		32 <sup>5</sup>			150 and up <sup>6</sup>	41.75						
F370x	900 <sup>5</sup>	36 <sup>5</sup>	1030.00		150 and up <sup>6</sup>	46	25 and up	1185	431.80	90	705	97
F395x	1000 <sup>5</sup>	40 <sup>5</sup>	1140.00		150 <sup>6</sup>	53	25 and up	1320	437.80	90	840	121

Note 1: Smallest pressure class flange fitting.  
 Note 2: Nominal weight, including inserts and packing material, exact weight is dependent on inserts.  
 Note 3: Fits PN25 and PN40 flanges with M18 studs or studs from ACC3320BD25.  
 Note 4: Hi-flow inserts does not fit in this wafer size.  
 Note 5: 450mm (18") and larger supplied with eyebolt for lifting.  
 Note 6: According to ASME B16.47 series A.

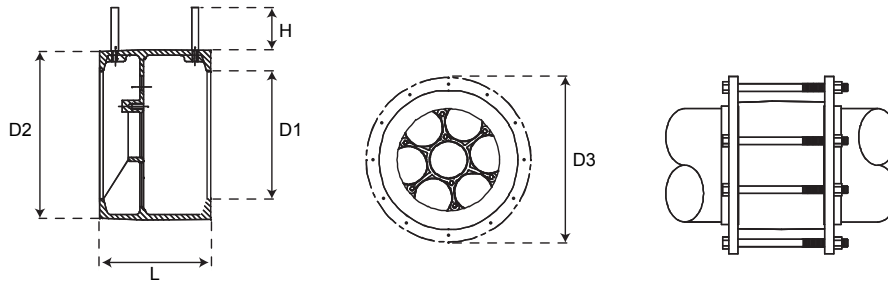

## MODEL NUMBER SELECTION<sup>7</sup>

Insert body size:  
**32**=100mm, 4"   **34**=150mm, 6"   **37**=200mm, 8"   **68**=250mm, 10"   **69**=300mm, 12"  
**39**=350mm, 14"   **84**=400mm, 16"   **85**=450mm, 18"   **38**=500mm, 20"  
**86**=600mm, 24"   **30**=800mm, 30"/32"   **70**=900mm, 36"   **95**=1000mm, 40"

Insert a kPaD control range:  
**0**=None  
 STANDARD/HI-CAP: **1**=10-135 kPaD and 28-135 kPaD   **2**=22-210 kPaD and 55-210 kPaD   **4**=40-390 kPaD   **8**=90-880 kPaD  
 HI-FLOW<sup>8</sup>:   **3**=20-125 kPaD   **5**=35-220 kPaD   **6**=55-220 kPaD

Insert p/t plug requirement:  
**B**=Pressure/temperature plugs

Example: F3370B=Wafer for 200mm flanges with p/t plugs and no inserts.  
**Note: Please specify flow requirements as per selection chart when ordering with inserts.**

Note 7: Model no. and flow rate are indicated on label affixed to body.  
 Note 8: Not possible for DN100.

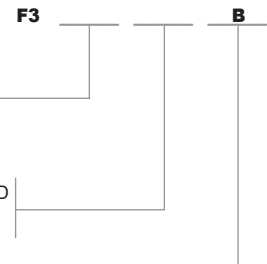

## FLOW RATE TABLE PER TYPE OF INSERT

80mm · 3" · stainless steel insert, standard flow								
			Pressure range, ΔP:					
			10-135 kPaD 1-20 psid	22-210 kPaD 2-32 psid	40-390 kPaD 4-57 psid	90-880 kPaD 8-128 psid		
Size (mm)	Size (")	Max no. of inserts	min. available l/sec l/sec increments	Type 1	Type 2	Type 4	Type 8	
				0.883	1.10	1.47	2.21	
100	4	2	max. available l/sec	7.58	9.46	12.62	18.92	
150	6	4		15.16	18.92	25.24	37.84	
200	8	7		26.53	33.11	44.17	66.22	
250	10	11		41.69	52.03	69.41	104.06	
300	12	15		56.85	70.95	94.65	141.90	
350	14	19		72.01	89.87	119.89	179.74	
400	16	24		90.96	113.52	151.44	227.04	
450	18	31		117.49	146.63	195.61	293.26	
500	20	37		140.23	175.01	233.47	350.02	
600	24	55		208.45	260.15	347.05	520.30	
800	30	85			322.15	402.05	536.35	804.10
	32							
900	36	97			367.63	458.81	612.07	917.62
1000	40	121			458.59	572.33	763.51	1144.66

Accuracy: ±5% of controlled flow rate.

80mm · 3" · stainless steel insert, high capacity							
			Pressure range, ΔP:				
			28-135 kPaD 4-20 psid		55-210 kPaD 8-32 psid		
Size (mm)	Size (")	Max no. of inserts	min. available l/sec l/sec increments	Type 1	Type 2		
				5.68	1.26	1.58	
100	4	2	max. available l/sec	16.4	20.2		
150	6	4		32.8	40.4		
200	8	7		57.4	70.7		
250	10	11		90.2	111.1		
300	12	15		123.0	151.5		
350	14	19		155.8	191.9		
400	16	24		196.8	242.4		
450	18	31		254.2	313.1		
500	20	37		303.4	373.7		
600	24	55		451.0	555.5		
800	30	85			697.0	858.5	
	32						
900	36	97			795.4	979.7	
1000	40	121			992.2	1222.1	

Accuracy: ±5% of controlled flow rate.

80mm · 3" · stainless steel insert, high flow							
			Pressure range, ΔP:				
			20-125 kPaD 3-18 psid	35-220 kPaD 5-32 psid	55-220 kPaD 8-32 psid		
Size (mm)	Size (")	Max no. of inserts	min. available l/sec l/sec increments	Type 3	Type 5	Type 6	
				6.31	8.52	18.9	
100	4	N/A	max. available l/sec	N/A	N/A <sup>9</sup>	N/A	
150	6	4		N/A	N/A	N/A	
200	8	7		25.24	50.4	75.6	
250	10	11		44.17	88.2	132.3	
300	12	15		69.41	138.6	207.9	
350	14	19		94.65	189.0	283.5	
400	16	24		119.89	239.4	359.1	
450	18	31		151.44	302.4	453.6	
500	20	37		195.61	390.6	585.9	
600	24	55		233.47	466.2	699.3	
800	30	85			347.05	693.0	1039.5
	32						
900	36	97			536.35	1071.0	1606.5
1000	40	121			612.07	1222.2	1833.3

Accuracy: ±5% of controlled flow rate.

Note 9: For flow rates in between min. and max. please contact FlowCon.

## GENERAL SPECIFICATIONS

### 1. AUTOMATIC BALANCING VALVES - FLOWCON WAFER

- 1.1. Contractor shall install automatic balancing valves where indicated in drawings.
- 1.2. Valve shall consist of a dynamic, flow limiting device.

### 2. VALVE HOUSING

- 2.1. Valve housing shall consist of ductile iron ASTM A536-65T, class 60-45-18, rated at no less than 3400 kPa static pressure and +175°C.
- 2.2. Valve shall be permanently marked to show direction of flow.
- 2.3. Dual pressure/temperature test plugs for verifying accuracy of flow performance shall be provided for all valve sizes.
- 2.4. Valve housing shall be compatible with ANSI B 16.5/16.47 150lb/300lb steel flanges (depending on size) and be compatible to DIN PN25+/PN40+ flanges (depending on size) according to EN1092-1.
- 2.5. Sizes 450mm and larger supplied with eyelet bolt for lifting.

### 3. FLOW REGULATOR / AUTOMATIC BALANCING UNIT

- 3.1. Flow regulation unit assembly shall be manufactured of AISI type 304 stainless steel and stainless steel 17-7 spring.
- 3.2. Flow regulation unit shall be available in 4 different kPaD operational range; minimum range shall be capable of being activated by minimum 10 kPaD. Further, the flow regulation unit shall be capable of controlling flow within  $\pm 5\%$  of rated flow.
- 3.3. Identification label according to PED-requirements shall be available for all valves.

## UPDATES

**For latest updates please see [www.flowcon.com](http://www.flowcon.com)**

FlowCon International can accept no responsibility for possible errors in any printed material.  
All rights reserved.

# FlowCon Uni-Flange Valve 65-80mm

*Automatic Flow Control - Accessible Pre-Set Insert(s)*

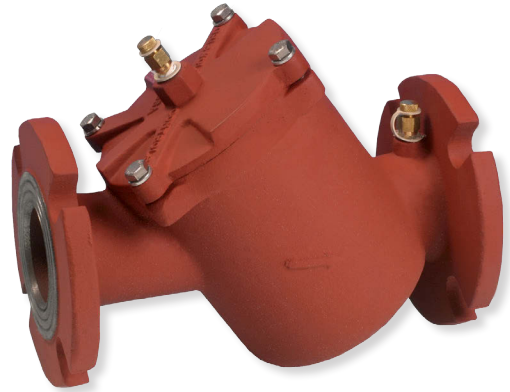

## SPECIFICATIONS

Pressure rating:	1030 kPa / 149 psi
Temperature rating:	+135°C / +275°F
Material:	
- Insert:	AISI Type 304 stainless steel AISI type 17-7 PH stainless steel spring
- Body:	Ductile iron ASTM A5236-80 class 50-40-18
- O-rings:	EPDM
End connections:	ANSI 150 lb. flanges 2 1/2" and 3"
Body tappings:	1/4" NPT with p/t plugs
Assembly:	Valve comes fully assembled
Flow rate range:	0.757-21.577 l/sec
Options:	Two 1/4"-1 1/4" p/t extensions Drain valve
Isolation options:	Butterfly valve

## DIMENSIONS AND WEIGHTS (NOMINAL) (measured in mm unless noted)

Model no.	Valve size	Insert size	L	H1	H2	Kv <sup>1</sup> (m <sup>3</sup> /H)	Weight (kgs.)
F3UFxxBx	65/80	50	301.5	133.4	109.2	105	12.7

Note 1: Kv-value measured without insert.

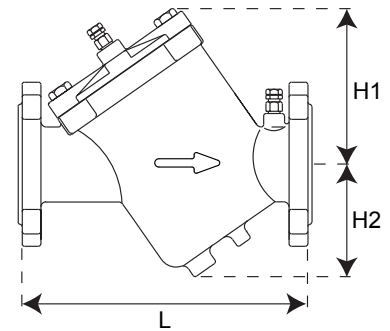

## MODEL NUMBER SELECTION<sup>2</sup>

Select a kPaD control range:  
**0**=none   **1**=10-95 kPaD   **2**=22-210 kPaD   **4**=40-390 kPaD   **8**=90-880 kPaD

Insert isolation option:  
**B**=none (standard)  
**M**=2 1/2" butterfly  
**N**=3" butterfly

Insert number of inserts:  
**1**=1x2" insert ("low" flow)  
**2**=2x2" insert ("medium" flow)  
**3**=3x2" insert ("high" flow)

Insert tag requirement:  
**T**=Optional aluminum hanging identification tag

**F3UF**

Example: F3UF0B2=Uni-Flange valve for 65/80mm flanges with p/t plugs and no insert or isolation.  
**Note: Please specify flow requirements as per selection chart when ordering with inserts.**

Note 2: Model no. and flow rate are indicated on label affixed to body.

## FLOW RATE TABLE

50mm · 2" · stainless steel insert							
				Pressure range, ΔP:			
				10-95 kPaD 1-14 psid	22-210 kPaD 2-32 psid	40-390 kPaD 4-57 psid	90-880 kPaD 8-128 psid
				Type 1	Type 2	Type 4	Type 8
Valve size (mm)	Valve size (")	No. of inserts	min. available l/sec	0.757	1.14	1.51	2.27
			l/sec increments	0.126	0.180	0.26	0.38
65/80	2 1/2"/3"	1	max. available l/sec	2.40	3.60	4.79	7.19
		2		4.80	7.20	9.58	14.38
		3		7.20	10.80	14.37	21.57

Accuracy: ±5% of controlled flow rate.

## GENERAL SPECIFICATIONS

### 1. AUTOMATIC BALANCING VALVES - UNI-FLANGE VALVE

- 1.1. Contractor shall install automatic balancing valves where indicated in drawings.
- 1.2. Valve shall consist of a dynamic and accessible flow limiting device.

### 2. VALVE HOUSING

- 2.1. Valve housing shall consist of ductile iron ASTM A536-80, Class 50-40-18, rated at no less than 1030 kPa static pressure and +135°C.
- 2.2. Valve housing shall be permanently marked to show direction of flow.
- 2.3. Valve shall be constructed in a one-piece housing.
- 2.4. Dual pressure/temperature test plugs for verifying accuracy of flow performance shall be provided for all valve sizes.
- 2.5. Valve housing shall be compatible with ANSI 150 lb. flanges 65mm (2 1/2") and 80mm (3").
- 2.6. Housing shall be configured for flow regulation unit accessibility.
- 2.7. Butterfly valve shall be available for all valves.

### 3. FLOW REGULATOR / AUTOMATIC BALANCING UNIT

- 3.1. Flow regulation unit assembly shall be manufactured of AISI type 304 stainless steel and stainless steel 17-7 spring.
- 3.2. Flow regulation unit shall be available in 4 different kPaD operational range; minimum range shall be capable of being activated by minimum 10 kPaD. Further, the flow regulation unit shall be capable of controlling flow within  $\pm 5\%$  of rated flow.
- 3.3. Identification tags shall be available for all valves; tags shall be indelibly marked with part number and flow rate.

## UPDATES

**For latest updates please see [www.flowcon.com](http://www.flowcon.com)**

FlowCon International can accept no responsibility for possible errors in any printed material.  
All rights reserved.

# FlowCon Grooved End 50-500mm

*Automatic Balancing Valve - Pre-Set Insert(s)*



## SPECIFICATIONS

Pressure rating:	2500 kPa / 360 psi
Temperature rating:	+95°C / +203°F
Material:	
- Insert:	AISI Type 304 stainless steel AISI Type 17-7 PH stainless steel spring
- Body:	Steel pipe schedule 40 (with cast iron grooved end clamps on DN50-DN80)
Body tappings:	1/4" NPT
Grooved end:	Please consult FlowCon for grooved end standards compatibility.
Flow rate range:	0.883-642.60 l/sec

## DIMENSIONS AND WEIGHTS (NOMINAL) (measured in mm unless noted)

Valve size	Valve size (")	Insert size	L	H	Weight (kgs.)	Max no. of inserts per Grooved End valve
50	2	80	406.4	115.8	6.6	1
65	2 1/2		406.4	115.8	6.6	1
80	3		203.2	115.8	4.0	1
100	4		431.8	218.9	17.7	3
125	5		304.8	218.9	16.1	3
150	6		304.8	218.9	16.1	3
200	8		406.4	323.9	29.3	6
250	10		406.4	323.9	41.4	8
300	12		711.2	406.4	81.8	14
350	14		1016.0	508.0	147.4	20
400	16		1016.0	609.6	204.1	26
450	18		1016.0	609.6	204.1	34
500	20		1016.0	609.6	204.1	34

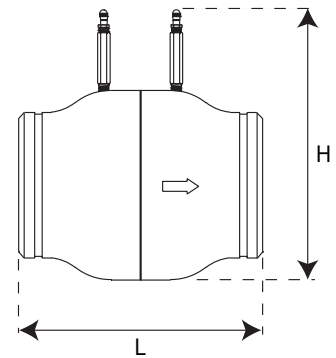

## MODEL NUMBER SELECTION

Insert body size:

**22**=50mm, 2"   **23**=65mm, 2 1/2"   **10**=80mm, 3"   **11**=100mm, 4"  
**12**=125mm, 5"   **13**=150mm, 6"   **14**=200mm, 8"   **15**=250mm, 10"  
**16**=300mm, 12"   **17**=350mm, 14"   **18**=400mm, 16"   **19**=450mm, 18"  
**70**=500mm, 20"

Insert a kPaD control range:

STANDARD: **1**=10-135 kPaD and 28-135 kPaD   **2**=22-210 kPaD and 55-210 kPaD   **4**=40-390 kPaD   **8**=90-880 kPaD  
 HI-FLOW:   **3**=20-125 kPaD   **5**=35-220 kPaD   **6**=55-220 kPaD

Insert p/t plug requirement:

**B**=Pressure/temperature plugs (standard)

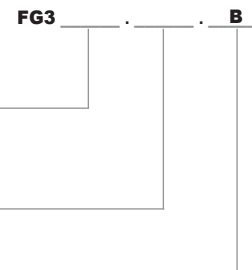

Example: FG313.0.B=Grooved End 150mm with p/t plugs and no insert.

**Note: Please specify flow requirements as per selection chart when ordering with inserts.**

## FLOW RATE TABLE PER TYPE OF INSERT

80mm · 3" · stainless steel insert, standard flow							
Pressure range, ΔP:				10-135 kPaD 1-20 psid	22-210 kPaD 2-32 psid	40-390 kPaD 4-57 psid	90-880 kPaD 8-128 psid
Valve size (mm)	Valve size (")	Max no. of cartridges	min. available l/sec l/sec increments	Type 1	Type 2	Type 4	Type 8
				<b>0.126</b>	<b>0.160</b>	<b>0.210</b>	<b>0.316</b>
50	2	1	Max. available l/sec	3.79	4.73	6.31	9.46
65	2 1/2	1		3.79	4.73	6.31	9.46
80	3	1		3.79	4.73	6.31	9.46
100	4	3		11.37	14.19	18.93	28.38
125	5	3		11.37	14.19	18.93	28.38
150	6	3		11.37	14.19	18.93	28.38
200	8	6		22.74	28.38	37.86	56.76
250	10	8		30.32	37.84	50.48	75.68
300	12	14		53.06	66.22	88.34	132.44
350	14	20		75.80	94.60	126.20	189.20
400	16	26		98.54	122.98	164.06	245.96
450	18	34		128.86	160.82	214.54	321.64
500	20	34		128.86	160.82	214.54	321.64

Accuracy: ±5% of controlled flow rate.

80mm · 3" · stainless steel insert, high capacity						
Pressure range, ΔP:				28-135 kPaD 4-20 psid	55-210 kPaD 8-32 psid	
Valve size (mm)	Valve size (")	Max no. of cartridges	min. available l/sec l/sec increments	Type 1	Type 2	
				<b>1.26</b>	<b>1.58</b>	
50	2	1	Max. available l/sec	8.2	10.1	
65	2 1/2	1		8.2	10.1	
80	3	1		8.2	10.1	
100	4	3		24.6	30.3	
125	5	3		24.6	30.3	
150	6	3		24.6	30.3	
200	8	6		49.2	60.6	
250	10	8		65.6	80.8	
300	12	14		114.8	141.4	
350	14	20		164.0	202.0	
400	16	26		213.2	262.6	
450	18	34		278.8	343.4	
500	20	34		278.8	343.4	

Accuracy: ±5% of controlled flow rate.

80mm · 3" · stainless steel insert, high flow						
Pressure range, ΔP:				20-125 kPaD 3-18 psid	35-220 kPaD 5-32 psid	55-220 kPaD 8-32 psid
Valve size (mm)	Valve size (")	Max no. of cartridges	min. available l/sec l/sec increments	Type 3	Type 5	Type 6
				<b>N/A</b>	<b>N/A<sup>1</sup></b>	<b>N/A</b>
50-80	2-3	1	Minimum l/sec	6.31	12.6	18.9
			Maximum l/sec			
100	4	3	Max. available l/sec	18.93	37.83	56.7
125	5	3		18.93	37.83	56.7
150	6	3		18.93	37.83	56.7
200	8	6		37.86	75.60	113.4
250	10	8		50.48	100.80	151.2
300	12	14		88.34	176.40	264.6
350	14	20		126.20	252.20	378.0
400	16	26		164.06	327.60	491.4
450	18	34		214.54	428.40	642.6
500	20	34		214.54	428.40	642.6

Accuracy: ±5% of controlled flow rate.

Note 1: For flow rates in between min. and max. please contact FlowCon.

## GENERAL SPECIFICATIONS

### 1. AUTOMATIC BALANCING VALVES - GROOVED END

- 1.1. Contractor shall install automatic balancing valves where indicated in drawings.
- 1.2. Valve shall consist of a dynamic, flow limiting device.

### 2. VALVE HOUSING

- 2.1. Valve housing shall consist of steel pipe, schedule 40 or greater, rated at no less than 2500 kPa static pressure and +95°C.
- 2.2. Valve housing shall be permanently marked to show direction of flow.
- 2.3. Dual pressure/temperature test plugs for verifying accuracy of flow performance shall be provided for all valve sizes.
- 2.4. Valve housing shall be compatible with grooved end clamps.

### 3. FLOW REGULATOR / AUTOMATIC BALANCING UNIT

- 3.1. Flow regulation unit assembly shall be manufactured of AISI type 304 stainless steel and stainless steel 17-7 spring.
- 3.2. Flow regulation unit shall be available in 4 different kPaD operational range; minimum range shall be capable of being activated by minimum 10 kPaD. Further, the flow regulation unit shall be capable of controlling flow within  $\pm 5\%$  of rated flow.
- 3.3. Identification tags shall be available for all valves; tags shall be indelibly marked with part number and flow rate.

## UPDATES

**For latest updates please see [www.flowcon.com](http://www.flowcon.com)**

FlowCon International can accept no responsibility for possible errors in any printed material.  
All rights reserved.

# FlowCon Inserts



*FlowCon Green Inserts, E-JUST Inserts,  
Composite Inserts and Stainless Steel Inserts*

# FlowCon Green Inserts

## Pressure Independent Control Valves



The FlowCon Green inserts ensure that the design flow will never be exceeded and with the matching modulating actuator any flow rate between closed and design flow is obtainable regardless of pressure fluctuations in the system maintaining 100% authority on the actuator always using full valve stroke independent of pre-set maximum flow.

### Adjustment

The valve is adjusted to a maximum flow rate limit by setting the scale located on the top of the Green insert. The setting indicates one of maximum 41 possible max flow rates, but since the setting is step less, any flow rate in between minimum and maximum is obtainable. The setting is done by means of a special FlowCon key. With the actuator mounted, the pre-setting is “sealed” and the FlowCon Green insert eliminates any flow above the design flow.

For re-adjustment, simply remove power from the actuator and then remove the actuator from the valve. Hereafter dial in a new required maximum flow and re-apply the actuator and re-apply the power.

### Applications

The FlowCon Green inserts can be used with the following FlowCon valves:

- FlowCon A (DN15/20/25)
- FlowCon AB (DN15/20/25/32)
- FlowCon ABV1 (DN15/20/25)
- FlowCon ABV2 (DN25/32/40)

### Principle of Insert Operation

On closer examination of the inner workings of the FlowCon Green, the function is best described as 2 valves in 1. The second valve (V2) regulates the pressure differential across the first valve (V1) by means of a rolling diaphragm element counter-acted by a spring. The first valve is a calibrated variable orifice device adjusted by the actuator (similar to a standard modulating control valve).

The diaphragm reacts to the system and regulates the pressure differential across the actuated control valve orifice to maintain its flow rate.

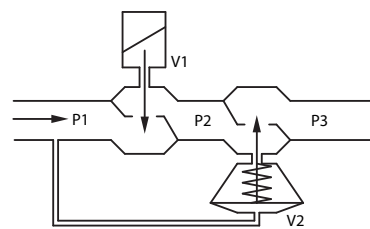

When pre-setting the maximum flow rate, the inlet orifice is changed in size sideways which does not interfere with the length of the stroke. When modulating, the orifice areas are affected by the actuator using the full stroke which results in the fact that the orifice area is changed in size in a vertical movement.

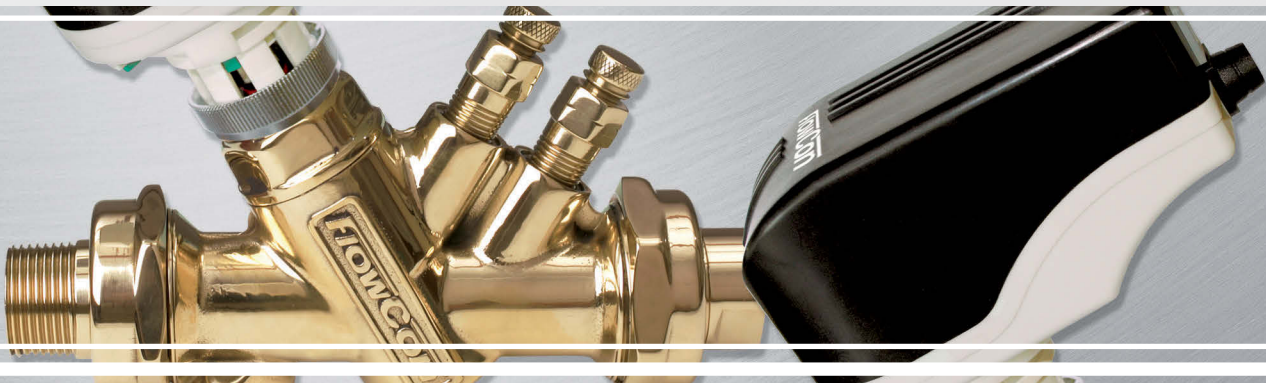

## 20mm (3/4") and 40mm (1 1/2") Green Inserts for DN15-DN40 Valves

FlowCon Green									
Insert: 20mm, 3/4"						Insert: 40mm, 1 1/2"			Setting
16-200 kPaD · 2.3-29 psid			30-400 kPaD · 4.4-58 psid			16-400 kPaD* · 2.3-58 psid*			
Green.0 (grey o-ring)			Green.1 (black o-ring)			Green.2 (black o-ring)			
I/sec	I/hr	GPM	I/sec	I/hr	GPM	I/sec	I/hr	GPM	
-	-	-	0.0178	64	0.282	0.240	865	3.81	1.0
0.0103	37	0.163	0.0393	142	0.624	0.282	1010	4.46	1.1
0.0233	84	0.370	0.0580	209	0.920	0.322	1160	5.10	1.2
0.0322	116	0.510	0.0743	268	1.180	0.361	1300	5.72	1.3
0.0419	151	0.664	0.0887	319	1.41	0.399	1430	6.32	1.4
0.0500	180	0.792	0.102	366	1.61	0.435	1570	6.90	1.5
0.0569	205	0.902	0.113	408	1.80	0.471	1700	7.47	1.6
0.0650	234	1.03	0.124	446	1.96	0.506	1820	8.02	1.7
0.0719	259	1.14	0.134	482	2.12	0.540	1940	8.56	1.8
0.0781	281	1.24	0.143	516	2.27	0.573	2060	9.08	1.9
0.0839	302	1.33	0.152	549	2.42	0.605	2180	9.59	2.0
0.0889	320	1.41	0.161	580	2.56	0.636	2290	10.1	2.1
0.0942	339	1.49	0.170	611	2.69	0.667	2400	10.6	2.2
0.0981	353	1.55	0.178	641	2.82	0.696	2510	11.0	2.3
0.103	371	1.63	0.186	671	2.95	0.725	2610	11.5	2.4
0.106	381	1.68	0.194	700	3.08	0.753	2710	11.9	2.5
0.109	394	1.73	0.202	728	3.21	0.780	2810	12.4	2.6
0.113	406	1.79	0.210	756	3.33	0.807	2900	12.8	2.7
0.115	414	1.82	0.218	783	3.45	0.832	3000	13.2	2.8
0.119	428	1.88	0.225	810	3.56	0.858	3090	13.6	2.9
0.122	439	1.93	0.232	835	3.68	0.882	3180	14.0	3.0
0.125	449	1.98	0.239	860	3.79	0.906	3260	14.4	3.1
0.127	458	2.02	0.245	883	3.89	0.930	3350	14.7	3.2
0.130	468	2.06	0.252	906	3.99	0.953	3430	15.1	3.3
0.133	477	2.10	0.257	927	4.08	0.975	3510	15.5	3.4
0.135	486	2.14	0.263	946	4.17	0.997	3590	15.8	3.5
0.137	494	2.17	0.268	965	4.25	1.02	3670	16.1	3.6
0.140	503	2.21	0.273	982	4.32	1.04	3740	16.5	3.7
0.142	511	2.25	0.277	998	4.39	1.06	3820	16.8	3.8
0.144	518	2.28	0.281	1010	4.46	1.08	3890	17.1	3.9
0.146	526	2.31	0.285	1020	4.51	1.10	3960	17.4	4.0
0.148	532	2.34	0.288	1040	4.57	1.12	4030	17.7	4.1
0.149	538	2.37	0.291	1050	4.61	1.14	4100	18.1	4.2
0.151	544	2.39	0.294	1060	4.66	1.16	4170	18.4	4.3
0.153	549	2.42	0.296	1070	4.70	1.18	4240	18.7	4.4
0.154	553	2.43	0.299	1080	4.73	1.20	4300	19.0	4.5
0.155	559	2.46	0.301	1080	4.77	1.21	4370	19.2	4.6
0.156	563	2.48	0.303	1090	4.80	1.23	4440	19.5	4.7
0.158	567	2.50	0.305	1100	4.83	1.25	4500	19.8	4.8
0.159	571	2.51	0.307	1100	4.86	1.27	4570	20.1	4.9
0.160	575	2.53	0.308	1110	4.89	1.29	4630	20.4	5.0

Nominal flow rate

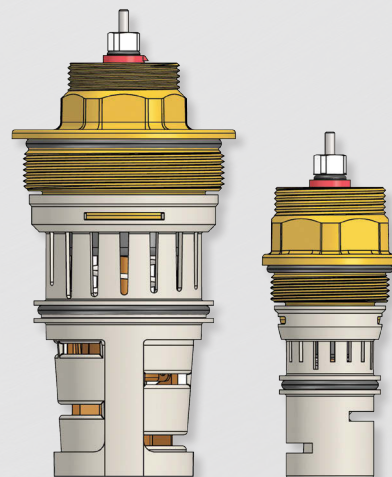

Accuracy: Greatest of either ±10% of controlled flow rate or ±5% of maximum flow rate.  
\*at setting 2.6.

# FlowCon E-JUST Inserts

Externally Adjustable Flow Rate Inserts for FlowCon Valves



The E-JUST automatic flow rate inserts ensure that the design flow will not be exceeded regardless of pressure fluctuations in the system.

## Adjustment

By means of a specially designed key each insert can be easily adjusted to one of 41 different flow rates. Adjustment is managed externally without isolating the valve or removing the insert from the system, which means that the desired maximum flow rate can be set while the system is operating.

The adjustment key turns the display mechanism and the graduation on the 'handle' of the insert shows the setting indicated by two scales; one black reflecting full turns numbered 1 through 5, and one red at the top reflecting tenths of full turns numbered 0 through 9. The number of turns reflects the flow rate selected (please see the next five pages in this brochure). The color of the pawl shows the selected control range, e.g. white = 17-210 kPaD for the 20mm black and green inserts.

The FlowCon E-JUST insert is tamper-proof since the adjustment is operated by means of the mentioned special key. Further, the setting can be protected with a colored top cover. The color of the cover and the o-ring on the spindle under the cover indicates the color and flow range of the insert, e.g. red for flow rates between 0.113-0.352 l/sec,  $\Delta P$  30-400 kPaD (grey pawl). E-JUST inserts size 40mm and 50mm will, as standard, always be with a black cover and black o-ring, as only one type per size is available.

## Principle of Insert Operation

The principle of operation is shown below. P1 and P3 are system pressures. P1+P3 is the total pressure

drop across the valve. P2 is set by the diaphragm acting in reaction to P1 in the upper diaphragm chamber. Interacting with the spring, P1+P2 remains constant, keeping a constant  $\Delta P$  across the orifice areas. The result is a constant flow rate through the valve, independent of pressure fluctuations.

Below its pressure differential range, it acts as a fixed orifice. This allows a control valve in the same circuit to operate with valve authority up to the specified flow rate.

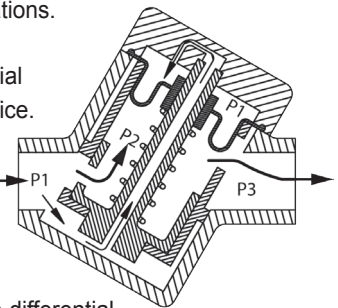

Within the defined pressure differential regulation range the pump supplies sufficient pressure to affect the spring and diaphragm in the insert.

In case the differential pressure is higher than the defined max.  $\Delta P$  for the insert, the diaphragm may be damaged.

## Applications

The FlowCon E-JUST inserts (20mm, 40mm and 50mm) can be used with the following FlowCon valves:

- |              |  |
|--------------|--|
| 20mm E-JUST: | - FlowCon A (DN15/20/25)<br>- FlowCon AB (DN15/20/25)<br>- FlowCon ABV1 (DN15/20/25)<br>- FlowCon EVC (DN15/20)<br>- FlowCon ABM1 (DN15/20/25) |
| 40mm E-JUST: | - FlowCon AB (DN25/32)<br>- FlowCon ABV2 (DN25/32/40)<br>- FlowCon ABM2 (DN25/32/40)   |
| 50mm E-JUST: | - FlowCon AB (DN40/50)   |



## 20mm (3/4") E-JUST Inserts for DN15-DN25 Valves

20mm · 3/4" · E-JUST · Y-type · White pawl					
Pressure range, ΔP: 17-210 kPaD · 2.5-30 psid					
Nominal flow rate	Model no.			E-JUST1.Y.B	E-JUST1.Y.G
	l/sec	l/hr	GPM	Black	Green
				Setting	Setting
0.0278	100	0.440	1.0		
0.0299	108	0.475	1.1		
0.0321	116	0.509	1.2		
0.0343	123	0.543	1.3		
0.0364	131	0.578	1.4		
0.0386	139	0.612	1.5		
0.0408	147	0.646	1.6		
0.0429	155	0.681	1.7		
0.0436	157	0.691		1.0	
0.0451	162	0.715	1.8		
0.0468	168	0.741		1.1	
0.0473	170	0.749	1.9		
0.0494	178	0.784	2.0		
0.0499	180	0.791		1.2	
0.0516	186	0.818	2.1		
0.0530	191	0.841		1.3	
0.0538	194	0.852	2.2		
0.0559	201	0.887	2.3		
0.0562	202	0.890		1.4	
0.0581	209	0.921	2.4		
0.0593	214	0.940		1.5	
0.0603	217	0.955	2.5		
0.0624	225	0.990	2.6	1.6	
0.0646	233	1.02	2.7		
0.0656	236	1.04		1.7	
0.0668	240	1.06	2.8		
0.0687	247	1.09		1.8	
0.0689	248	1.09	2.9		
0.0711	256	1.13	3.0		
0.0719	259	1.14		1.9	
0.0733	264	1.16	3.1		
0.0750	270	1.19		2.0	
0.0754	272	1.20	3.2		
0.0776	279	1.23	3.3		
0.0781	281	1.24		2.1	
0.0798	287	1.26	3.4		
0.0813	293	1.29		2.2	
0.0819	295	1.30	3.5		
0.0841	303	1.33	3.6		
0.0844	304	1.34		2.3	
0.0863	311	1.37	3.7		
0.0876	315	1.39		2.4	
0.0884	318	1.40	3.8		

Continue next column...

20mm · 3/4" · E-JUST · Y-type · White pawl					
Pressure range, ΔP: 17-210 kPaD · 2.5-30 psid					
Nominal flow rate	Model no.			E-JUST1.Y.B	E-JUST1.Y.G
	l/sec	l/hr	GPM	Black	Green
				Setting	Setting
0.0906	326	1.44	3.9		
0.0907	327	1.44		2.5	
0.0928	334	1.47	4.0		
0.0938	338	1.49		2.6	
0.0949	342	1.50	4.1		
0.0970	349	1.54		2.7	
0.0971	350	1.54	4.2		
0.0993	357	1.57	4.3		
0.100	360	1.59		2.8	
0.101	365	1.61	4.4		
0.103	372	1.64		2.9	
0.104	373	1.64	4.5		
0.106	381	1.68	4.6		
0.106	383	1.69		3.0	
0.108	389	1.71	4.7		
0.110	394	1.74		3.1	
0.110	396	1.75	4.8		
0.112	404	1.78	4.9		
0.113	406	1.79		3.2	
0.114	412	1.81	5.0		
0.116	417	1.84		3.3	
0.119	428	1.89		3.4	
0.122	440	1.94		3.5	
0.125	451	1.98		3.6	
0.128	462	2.03		3.7	
0.132	473	2.08		3.8	
0.135	485	2.13		3.9	
0.138	496	2.18		4.0	
0.141	507	2.23		4.1	
0.144	519	2.28		4.2	
0.147	530	2.33		4.3	
0.150	541	2.38		4.4	
0.153	553	2.43		4.5	
0.157	564	2.48		4.6	
0.160	575	2.53		4.7	
0.163	586	2.58		4.8	
0.166	598	2.63		4.9	
0.169	609	2.68		5.0	

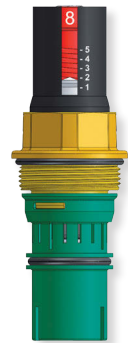

Accuracy: Greatest of either ±5% of controlled flow rate or ±2% of maximum flow rate

# FlowCon E-JUST Inserts

## 20mm (3/4") E-JUST Inserts for DN15-DN25 Valves

20mm · 3/4" · E-JUST · Y-type · White pawl				
Pressure range. ΔP: 17-200 kPaD · 2.5-29 psid				
Nominal flow rate	Model no. E-JUST1.Y.R			Red
	I/sec	I/hr	GPM	Setting
	0.0767	276	1.22	1.0
0.0813	293	1.29	1.1	
0.0860	310	1.36	1.2	
0.0907	326	1.44	1.3	
0.0953	343	1.51	1.4	
0.100	360	1.58	1.5	
0.105	377	1.66	1.6	
0.109	393	1.73	1.7	
0.114	410	1.80	1.8	
0.118	426	1.88	1.9	
0.123	443	1.95	2.0	
0.128	459	2.02	2.1	
0.132	475	2.09	2.2	
0.136	491	2.16	2.3	
0.141	507	2.23	2.4	
0.145	523	2.30	2.5	
0.150	539	2.37	2.6	
0.154	554	2.44	2.7	
0.158	569	2.51	2.8	
0.162	584	2.57	2.9	
0.166	599	2.64	3.0	
0.170	614	2.70	3.1	
0.174	628	2.76	3.2	
0.178	642	2.83	3.3	
0.182	655	2.89	3.4	
0.186	669	2.94	3.5	
0.189	682	3.00	3.6	
0.193	695	3.06	3.7	
0.196	707	3.11	3.8	
0.200	719	3.17	3.9	
0.203	731	3.22	4.0	
0.206	742	3.27	4.1	
0.209	753	3.32	4.2	
0.212	764	3.36	4.3	
0.215	774	3.41	4.4	
0.218	784	3.45	4.5	
0.220	793	3.49	4.6	
0.223	802	3.53	4.7	
0.225	810	3.57	4.8	
0.227	818	3.60	4.9	
0.229	825	3.60	5.0	

Accuracy: Greatest of either ±5% of controlled flow rate or ±2% of maximum flow rate

20mm · 3/4" · E-JUST · G-type · Grey pawl				
Pressure range. ΔP: 30-400 kPaD · 4.4-58 psid				
Nominal flow rate	Model no. E-JUST1.G.R			Red
	I/sec	I/hr	GPM	Setting
	0.113	406	1.79	1.0
0.119	427	1.88	1.1	
0.125	449	1.98	1.2	
0.131	470	2.07	1.3	
0.137	492	2.17	1.4	
0.143	513	2.26	1.5	
0.149	535	2.36	1.6	
0.155	556	2.45	1.7	
0.161	578	2.54	1.8	
0.167	599	2.64	1.9	
0.172	621	2.73	2.0	
0.178	642	2.83	2.1	
0.184	664	2.92	2.2	
0.190	685	3.02	2.3	
0.196	707	3.11	2.4	
0.202	728	3.21	2.5	
0.208	750	3.30	2.6	
0.214	771	3.40	2.7	
0.220	793	3.49	2.8	
0.226	814	3.59	2.9	
0.232	836	3.68	3.0	
0.238	857	3.78	3.1	
0.244	879	3.87	3.2	
0.250	900	3.96	3.3	
0.256	922	4.06	3.4	
0.262	943	4.15	3.5	
0.268	965	4.25	3.6	
0.274	987	4.34	3.7	
0.280	1010	4.44	3.8	
0.286	1030	4.53	3.9	
0.292	1050	4.63	4.0	
0.298	1070	4.72	4.1	
0.304	1090	4.82	4.2	
0.310	1120	4.91	4.3	
0.316	1140	5.01	4.4	
0.322	1160	5.10	4.5	
0.328	1180	5.20	4.6	
0.334	1200	5.29	4.7	
0.340	1220	5.38	4.8	
0.346	1240	5.48	4.9	
0.352	1270	5.57	5.0	

Accuracy: Greatest of either ±5% of controlled flow rate or ±2% of maximum flow rate

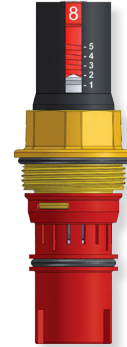

# FlowCon E-JUST Inserts

## 20mm (3/4") E-JUST Inserts for DN15-DN25 Valves

20mm · 3/4" · E-JUST · G-type · Grey pawl					
Pressure range, ΔP: 35-400 kPaD · 5.1-58 psid					
Nominal flow rate	Model no.			E-JUST1.G.B	E-JUST1.G.G
	l/sec	l/hr	GPM	Black	Green
				Setting	Setting
	0.0383	138	0.607	1.0	
	0.0416	150	0.660	1.1	
	0.0449	162	0.712	1.2	
	0.0483	174	0.765	1.3	
	0.0516	186	0.817	1.4	
	0.0549	198	0.870	1.5	
	0.0582	210	0.922	1.6	
	0.0615	221	0.975	1.7	
	0.0648	233	1.03	1.8	
	0.0660	238	1.05		1.0
	0.0681	245	1.08	1.9	
	0.0706	254	1.12		1.1
	0.0714	257	1.13	2.0	
	0.0748	269	1.18	2.1	
	0.0751	271	1.19		1.2
	0.0781	281	1.24	2.2	
	0.0797	287	1.26		1.3
	0.0814	293	1.29	2.3	
	0.0843	304	1.34		1.4
	0.0847	305	1.34	2.4	
	0.0880	317	1.40	2.5	
	0.0889	320	1.41		1.5
	0.0913	329	1.45	2.6	
	0.0934	336	1.48		1.6
	0.0946	341	1.50	2.7	
	0.0979	353	1.55	2.8	
	0.0980	353	1.55		1.7
	0.101	365	1.61	2.9	
	0.103	369	1.63		1.8
	0.105	377	1.66	3.0	
	0.107	386	1.70		1.9
	0.108	388	1.71	3.1	
	0.111	400	1.76	3.2	
	0.112	402	1.77		2.0
	0.115	412	1.82	3.3	
	0.116	419	1.84		2.1
	0.118	424	1.87	3.4	
	0.121	435	1.92		2.2
	0.121	436	1.92	3.5	
	0.124	448	1.97	3.6	
	0.125	452	1.99		2.3
	0.128	460	2.03	3.7	
	0.130	468	2.06		2.4
	0.131	472	2.08	3.8	
	0.134	484	2.13	3.9	
	0.135	485	2.13		2.5
	0.138	496	2.18	4.0	
	0.139	501	2.21		2.6
	0.141	508	2.24	4.1	
	0.144	517	2.28		2.7
	0.144	520	2.29	4.2	
	0.148	532	2.34	4.3	
	0.148	534	2.35		2.8
	0.151	544	2.39	4.4	
	0.153	550	2.42		2.9
	0.154	556	2.45	4.5	
	0.157	567	2.50		3.0
	0.158	567	2.50	4.6	
	0.161	579	2.55	4.7	
	0.162	583	2.57		3.1
	0.164	591	2.60	4.8	
	0.167	600	2.64		3.2
	0.168	603	2.66	4.9	
	0.171	615	2.71	5.0	

Continue next column...

20mm · 3/4" · E-JUST · G-type · Grey pawl					
Pressure range, ΔP: 35-400 kPaD · 5.1-58 psid					
Nominal flow rate	Model no.			E-JUST1.G.B	E-JUST1.G.G
	l/sec	l/hr	GPM	Black	Green
				Settings	Settings
	0.171	616	2.71		3.3
	0.176	633	2.79		3.4
	0.180	649	2.86		3.5
	0.185	666	2.93		3.6
	0.189	682	3.00		3.7
	0.194	699	3.08		3.8
	0.199	715	3.15		3.9
	0.203	731	3.22		4.0
	0.208	748	3.29		4.1
	0.212	764	3.37		4.2
	0.217	781	3.44		4.3
	0.221	797	3.51		4.4
	0.226	814	3.58		4.5
	0.231	830	3.66		4.6
	0.235	847	3.73		4.7
	0.240	863	3.80		4.8
	0.244	880	3.87		4.9
	0.249	896	3.95		5.0

Accuracy: Greatest of either  
±5% of controlled flow rate or  
±2% of maximum flow rate



# FlowCon E-JUST Inserts

## 40mm (1 1/2") E-JUST Inserts for DN25-DN40 Valves

40mm · 1 1/2" · E-JUST · Y-type · White pawl				
Pressure range, ΔP: 17-400 kPaD · 2.5-58 psid				
Model no.				E-JUST2.Y.G
Nominal flow rate	l/sec	l/hr	GPM	Setting
	0.149	535	2.36	1.0
	0.220	793	3.49	1.1
	0.289	1040	4.58	1.2
	0.355	1280	5.63	1.3
	0.418	1510	6.63	1.4
	0.479	1730	7.60	1.5
	0.538	1940	8.52	1.6
	0.594	2140	9.41	1.7
	0.647	2330	10.3	1.8
	0.699	2520	11.1	1.9
	0.748	2690	11.9	2.0
	0.795	2860	12.6	2.1
	0.841	3030	13.3	2.2
	0.884	3180	14.0	2.3
	0.925	3330	14.7	2.4
	0.965	3470	15.3	2.5
	1.00	3610	15.9	2.6
	1.04	3740	16.5	2.7
	1.07	3870	17.0	2.8
	1.11	3990	17.6	2.9
	1.14	4100	18.1	3.0
	1.17	4220	18.6	3.1
	1.20	4320	19.0	3.2
	1.23	4420	19.5	3.3
	1.26	4520	19.9	3.4
	1.28	4620	20.3	3.5
	1.31	4710	20.7	3.6
1.33	4800	21.1	3.7	
1.36	4890	21.5	3.8	
1.38	4970	21.9	3.9	
1.40	5050	22.3	4.0	
1.43	5130	22.6	4.1	
1.45	5210	23.0	4.2	
1.47	5290	23.3	4.3	
1.49	5370	23.6	4.4	
1.51	5440	24.0	4.5	
1.53	5520	24.3	4.6	
1.55	5600	24.6	4.7	
1.58	5670	25.0	4.8	
1.60	5750	25.3	4.9	
1.62	5830	25.7	5.0	

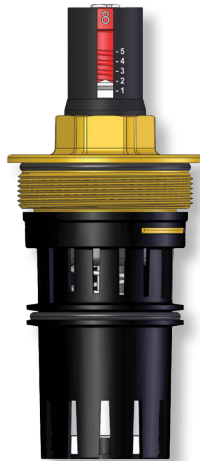

Accuracy: Greatest of either ±5% of controlled flow rate or ±2% of maximum flow rate

# FlowCon E-JUST Inserts

## 50mm (2") E-JUST Inserts for DN40 and DN50 Valves

50mm · 2" · E-JUST · G-type · Grey pawl				
Pressure range. ΔP: 20-400 kPaD · 2.9-58 psid				
		Model no.	E-JUST3.G.B	
Nominal flow rate	l/sec	l/hr	GPM	Setting
	0.883	3180	14.0	1.0
	1.14	4100	18.0	1.1
	1.37	4940	21.7	1.2
	1.59	5710	25.1	1.3
	1.78	6420	28.3	1.4
	1.96	7070	31.1	1.5
	2.13	7660	33.7	1.6
	2.28	8200	36.1	1.7
	2.42	8700	38.3	1.8
	2.54	9150	40.3	1.9
	2.66	9570	42.1	2.0
	2.77	9960	43.8	2.1
	2.86	10300	45.4	2.2
	2.95	10600	46.8	2.3
	3.04	10900	48.2	2.4
	3.12	11200	49.4	2.5
	3.19	11500	50.6	2.6
	3.26	11700	51.7	2.7
	3.32	12000	52.7	2.8
	3.39	12200	53.7	2.9
	3.45	12400	54.6	3.0
	3.51	12600	55.6	3.1
	3.56	12800	56.5	3.2
	3.62	13000	57.3	3.3
	3.67	13200	58.2	3.4
	3.73	13400	59.1	3.5
	3.78	13600	59.9	3.6
3.83	13800	60.8	3.7	
3.89	14000	61.6	3.8	
3.94	14200	62.4	3.9	
3.99	14400	63.3	4.0	
4.05	14600	64.1	4.1	
4.10	14800	65.0	4.2	
4.15	14900	65.8	4.3	
4.20	15100	66.6	4.4	
4.25	15300	67.4	4.5	
4.30	15500	68.2	4.6	
4.35	15700	68.9	4.7	
4.39	15800	69.6	4.8	
4.44	16000	70.3	4.9	
4.48	16100	70.9	5.0	

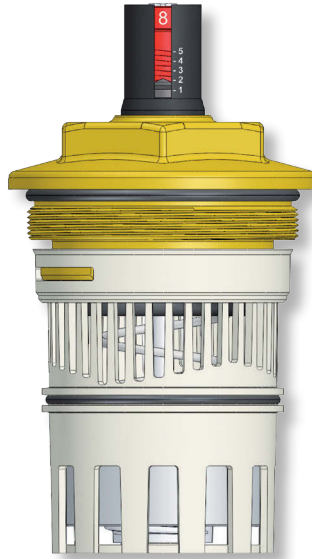

Accuracy: Greatest of  
either  $\pm 5\%$  of controlled flow rate  
or  $\pm 2\%$  of maximum flow rate

# FlowCon Composite Inserts

Adjustable Flow Rate Inserts for FlowCon Valves

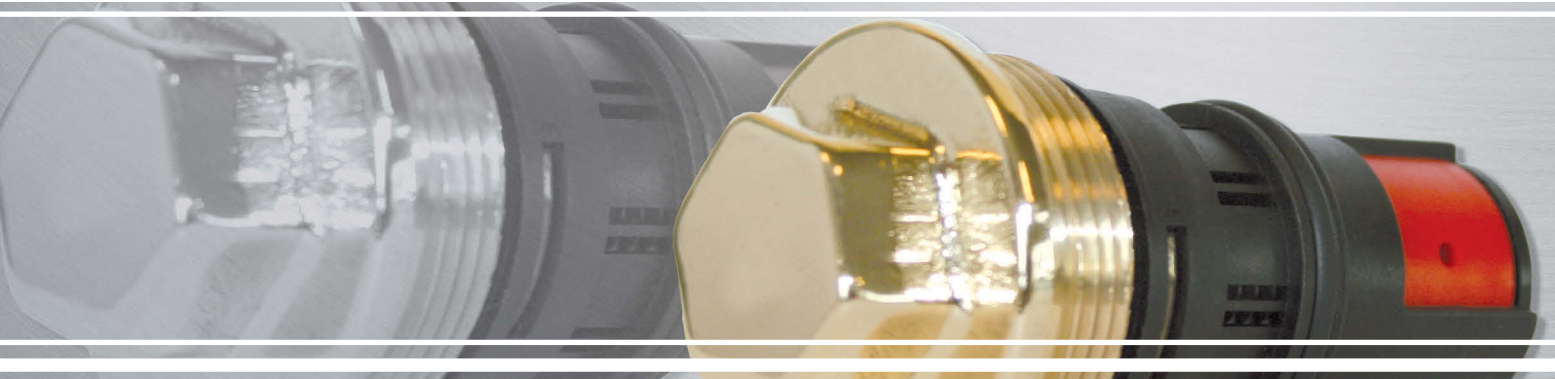

## 20mm (3/4") Composite Inserts for DN15-DN25 Valves

20mm · 3/4" · composite insert · Y-type								
Pressure range, ΔP: 20-130 kPaD (15-130 kPaD)* · 2.9-18.9 psid (2.2-18.9 psid)*								
Nominal flow rate	Model no.			ABV1.Y.Y	ABV1.Y.R	ABV1.Y.U	ABV1.Y.B	ABV1.Y.G
	l/sec	l/hr	GPM	Grey*	Red	Blue	Black	Green
0.0081	29.2	0.128	1					
0.0133	47.9	0.211	2					
0.0175	63.0	0.277	3					
0.0222	79.9	0.352	4					
0.0311	112	0.493	5					
0.0353	127	0.560	6					
0.0383	138	0.607	7					
0.0431	155	0.683	8					
0.0450	162	0.713					3	
0.0575	207	0.911		4				
0.0619	223	0.981			4			
0.0669	241	1.06					4	
0.0922	332	1.46		5				
0.0978	352	1.55						1
0.105	378	1.66		6				
0.114	409	1.80		7				
0.115	415	1.83			5			
0.118	426	1.88						2
0.119	430	1.89		8				
0.136	489	2.15						3
0.137	492	2.17			6			
0.138	498	2.19						4
0.146	524	2.31			7			
0.146	526	2.32			8			
0.155	557	2.45					5	
0.176	635	2.80					6	
0.180	647	2.85					7	
0.193	695	3.06					8	
0.231	830	3.66						5
0.237	854	3.76						6
0.253	909	4.00						7
0.273	984	4.33						8

Accuracy: Greatest of either ±10% of controlled flow rate or 20 l/hr (0.0056 l/sec or 0.088 GPM).

20mm · 3/4" · composite insert · G-type								
Pressure range, ΔP: 40-400 kPaD (30-400 kPaD)* · 5.8-58 psid (4.4-58 psid)*								
Nominal flow rate	Model no.			ABV1.G.Y	ABV1.G.R	ABV1.G.U	ABV1.G.B	ABV1.G.G
	l/sec	l/hr	GPM	Grey*	Red	Blue	Black	Green
0.0117	42.1	0.185	1					
0.0189	68.0	0.300	2					
0.0247	88.9	0.392	3					
0.0325	117	0.515	4					
0.0472	170	0.748	5					
0.0528	190	0.837	6					
0.0564	203	0.894				3		
0.0597	215	0.946					3	
0.0639	230	1.01	7					
0.0694	250	1.10	8					
0.0781	281	1.24		4				
0.0908	327	1.44				4		
0.0958	345	1.52					4	
0.137	493	2.17		5				
0.147	529	2.33						1
0.161	581	2.56		6				
0.173	624	2.75		7				
0.181	652	2.87				5		
0.181	653	2.88		8				
0.186	670	2.95						2
0.210	755	3.32						3
0.216	779	3.43				6		
0.218	785	3.46				7		
0.220	792	3.49				8		
0.237	853	3.75					5	
0.241	869	3.83						4
0.266	957	4.21					6	
0.269	968	4.26					7	
0.277	998	4.39					8	
0.365	1320	5.79						5
0.369	1330	5.85						6
0.392	1410	6.21						7
0.408	1470	6.46						8

Accuracy: Greatest of either ±10% of controlled flow rate or 20 l/hr (0.0056 l/sec or 0.088 GPM).





The composite automatic flow rate inserts ensure that the design flow will not be exceeded regardless of pressure fluctuations in the system.

#### Adjustment

By means of a Hex key each insert can be easily adjusted to one of eight different flow rates. Adjustment is managed 'internally' and therefore the valve must be isolated and the insert removed from the valve body, before adjusting is possible.

The groove at the bottom of the insert indicates the selected flow rate setting, numbered 1 through 8 (please see below and previous page). The color of

the insert shows the selected flow range and the letter stamped on the cap of the insert indicates the control range, e.g. Y-GREEN = 20-130 kPaD and flow rates from 0.0978-0.273 l/sec.

#### Applications and

**Principle of Insert Operation** are similar to the ones for E-JUST insert.

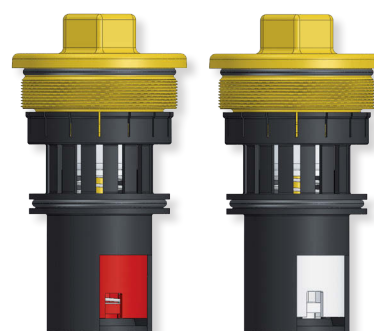

### 40mm (1 1/2") Composite Inserts for DN25-DN40 Valves

40mm · 1 1/2" composite insert · X-type					40mm · 1 1/2" composite insert · C-type					40mm · 1 1/2" composite insert · D-type					
Pressure range, ΔP: 15-130 kPaD · 2.2-18.9 psid					Pressure range, ΔP: 22-300 kPaD · 3.2-43.5 psid					Pressure range, ΔP: 30-410 kPaD · 4.4-59.5 psid					
Model no.		ABV2.X.W	ABV2.X.R	Model no.		ABV2.C.W	ABV2.C.R	Model No.		ABV2.D.W	ABV2.D.R				
Nominal flow rate	l/sec	l/hr	GPM	White	Red	l/sec	l/hr	GPM	White	Red	l/sec	l/hr	GPM	White	Red
	0.17	612	2.69	1		0.23	828	3.65	1		0.27	972	4.28	1	
	0.23	828	3.64	2		0.31	1120	4.91	2		0.36	1300	5.71	2	
	0.26	936	4.12		1	0.38	1370	6.02		1	0.44	1580	6.97		1
	0.33	1190	5.23	3		0.42	1510	6.66	3		0.52	1870	8.24	3	
	0.38	1370	6.02	4		0.47	1690	7.45	4		0.58	2090	9.19	4	
	0.39	1400	6.18		2	0.50	1800	7.93		2	0.60	2160	9.51		2
	0.48	1730	7.61	5	3	0.60	2160	9.51	5		0.74	2660	11.7	5	
	0.54	1940	8.56	6		0.64	2300	10.1		3	0.76	2740	12.0		3
	0.62	2230	9.83	7		0.68	2450	10.8	6		0.83	2990	13.2	6	
	0.63	2270	9.99		4	0.78	2810	12.4	7		0.93	3350	14.7	7	
	0.66	2380	10.5	8		0.83	2990	13.2		4	0.99	3560	15.7	8	4
	0.67	2410	10.6		5	0.84	3020	13.3	8		1.07	3850	17.0		5
	0.76	2740	12.0		6	0.90	3240	14.3		5	1.28	4610	20.3		6
	0.85	3060	13.5		7	1.07	3850	17.0		6	1.39	5000	22.0		7
						1.17	4210	18.5		7	1.43	5150	22.7		8
					1.21	4360	19.2		8						

Accuracy: Greatest of either ±10% of controlled flow rate or 20 l/hr (0.0056 l/sec or 0.088 GPM).

# Stainless Steel Inserts

## Pre-Set Flow Rate Inserts for FlowCon Valves



The stainless steel flow rate inserts ensure that the design flow will not be exceeded regardless of pressure fluctuations in the system. Since the insert is factory pre-set, the flow rate cannot be adjusted on the insert. The advantage of this type of insert is that it works at lower pressure differentials and with higher flows.

### Principle of Operation

Below the stainless steel insert's pressure differential range it acts as a fixed orifice.

Within operating pressure differential range, the effective open orifice area of the insert is automatically adjusted to the point where the specified flow rate will be delivered (as the pressure differential increases, the open area closes and as it decreases, the area opens).

When the pressure differential range is exceeded, the valve again becomes a fixed orifice device. This ensures that no part of the system is starved or shut down.

## 20mm (3/4") Stainless Steel Inserts for DN15-DN25 Valves

20mm · 3/4" · stainless steel insert											
Pressure range, ΔP:			10-95 kPaD 1-14 psid		22-210 kPaD 2-32 psid		40-390 kPaD 4-57 psid		90-880 kPaD 8-128 psid		
Nominal flow rate	l/sec	l/hr	GPM	Type 1		Type 2		Type 4		Type 8	
				Marking	FlowCon	Marking	FlowCon	Marking	FlowCon	Marking	FlowCon
0.0210	75.7	0.333		11-1	F360111						
0.0315	114	0.500		01-1	F360101						
0.0347	125	0.550				11-2	F360211				
0.0421	151	0.667		02-1	F360102						
0.0473	170	0.750				01-2	F360201	11-4	F360411		
0.0631	227	1.00		03-1	F360103	02-2	F360202	01-4	F360401		
0.0694	250	1.10								11-8	F360811
0.0841	303	1.33		04-1	F360104			02-4	F360402		
0.0946	341	1.50				03-2	F360203			01-8	F360801
0.105	379	1.67		05-1	F360105						
0.126	454	2.00		06-1	F360106	04-2	F360204	03-4	F360403	02-8	F360802
0.147	530	2.33		07-1	F360107						
0.158	568	2.50				05-2	F360205				
0.168	606	2.67		08-1	F360108			04-4	F360404		
0.189	681	3.00				06-2	F360206			03-8	F360803
0.210	757	3.33		10-1	F360110			05-4	F360405		
0.221	795	3.50				07-2	F360207				
0.252	908	4.00		12-1	F360112	08-2	F360208	06-4	F360406	04-8	F360804
0.294	1060	4.67		14-1	F360114			07-4	F360407		
0.315	1140	5.00		16-1	F360116	10-2	F360210			05-8	F360805
0.336	1210	5.33						08-4	F360408		
0.379	1360	6.00				12-2	F360212			06-8	F360806
0.421	1510	6.67						10-4	F360410		
0.442	1590	7.00				14-2	F360214			07-8	F360807
0.505	1820	8.00				16-2	F360216	12-4	F360412	08-8	F360808
0.589	2120	9.33						14-4	F360414		
0.631	2270	10.0						16-4	F360416	10-8	F360810
0.757	2730	12.0								12-8	F360812
0.883	3180	14.0								14-8	F360814
1.01	3630	16.0								16-8	F360816



Accuracy: ±5% of controlled flow rate.



## 40mm (1 1/2") Stainless Steel Inserts for DN25-DN40 Valves

40mm · 1 1/2" · stainless steel insert										
Pressure range, ΔP:			10-95 kPaD 1-14 psid		22-210 kPaD 2-32 psid		40-390 kPaD 4-57 psid		90-880 kPaD 8-128 psid	
l/sec	l/hr	GPM	Type 1		Type 2		Type 4		Type 8	
			Marking	FlowCon	Marking	FlowCon	Marking	FlowCon	Marking	FlowCon
0.189	681	3.00	09-1	F361109						
0.210	757	3.33	10-1	F361110						
0.252	908	4.00	12-1	F361112						
0.284	1020	4.50			09-2	F361209				
0.294	1060	4.67	14-1	F361114						
0.315	1140	5.00			10-2	F361210				
0.336	1210	5.33	16-1	F361116						
0.379	1360	6.00	18-1	F361118	12-2	F361212	09-4	F361409		
0.421	1510	6.67	20-1	F361120			10-4	F361410		
0.442	1590	7.00			14-2	F361214				
0.463	1670	7.33	22-1	F361122						
0.505	1820	8.00	24-1	F361124	16-2	F361216	12-4	F361412		
0.547	1970	8.67	26-1	F361126						
0.568	2040	9.00			18-2	F361218			09-8	F361809
0.589	2120	9.33	28-1	F361128			14-4	F361414		
0.631	2270	10.0	30-1	F361130	20-2	F361220			10-8	F361810
0.673	2420	10.7	32-1	F361132			16-4	F361416		
0.694	2500	11.0			22-2	F361222				
0.715	2570	11.3	34-1	F361134						
0.757	2730	12.0	36-1	F361136	24-2	F361224	18-4	F361418	12-8	F361812
0.799	2880	12.7	38-1	F361138						
0.820	2950	13.0			26-2	F361226				
0.841	3030	13.3	40-1	F361140			20-4	F361420		
0.883	3180	14.0	42-1	F361142	28-2	F361228			14-8	F361814
0.925	3330	14.7	44-1	F361144			22-4	F361422		
0.946	3410	15.0			30-2	F361230				
1.01	3630	16.0			32-2	F361232	24-4	F361424	16-8	F361816
1.07	3860	17.0			34-2	F361234				
1.09	3940	17.3					26-4	F361426		
1.14	4090	18.0			36-2	F361236			18-8	F361818
1.18	4240	18.7					28-4	F361428		
1.20	4320	19.0			38-2	F361238				
1.26	4540	20.0			40-2	F361240	30-4	F361430	20-8	F361820
1.32	4770	21.0			42-2	F361242				
1.35	4850	21.3					32-4	F361432		
1.39	5000	22.0			44-2	F361244			22-8	F361822
1.43	5150	22.7					34-4	F361434		
1.51	5450	24.0					36-4	F361436	24-8	F361824
1.60	5750	25.3					38-4	F361438		
1.64	5910	26.0							26-8	F361826
1.68	6060	26.7					40-4	F361440		
1.77	6360	28.0					42-4	F361442	28-8	F361828
1.85	6660	29.3					44-4	F361444		
1.89	6810	30.0							30-8	F361830
2.02	7270	32.0							32-8	F361832
2.15	7720	34.0							34-8	F361834
2.27	8180	36.0							36-8	F361836
2.40	8630	38.0							38-8	F361838
2.52	9080	40.0							40-8	F361840
2.65	9540	42.0							42-8	F361842
2.78	9990	44.0							44-8	F361844



Accuracy: ±5% of controlled flow rate.

# Stainless Steel Inserts

## 50mm (2") Stainless Steel Inserts for DN40-DN80 Valves

50mm · 2" · stainless steel insert										
Pressure range, ΔP:			10-95 kPaD 1-14 psid		22-210 kPaD 2-32 psid		40-390 kPaD 4-57 psid		90-880 kPaD 8-128 psid	
l/sec	l/hr	GPM	Type 1		Type 2		Type 4		Type 8	
			Marking	FlowCon	Marking	FlowCon	Marking	FlowCon	Marking	FlowCon
0.757	2730	12.0	36-1	F3C2136						
0.883	3180	14.0	42-1	F3C2142						
1.01	3630	16.0	48-1	F3C2148						
1.14	4090	18.0	54-1	F3C2154	36-2	F3C2236				
1.26	4540	20.0	60-1	F3C2160						
1.32	4770	21.0			42-2	F3C2242				
1.39	5000	22.0	66-1	F3C2166						
1.51	5450	24.0	72-1	F3C2172	48-2	F3C2248	36-4	F3C2436		
1.64	5910	26.0	78-1	F3C2178						
1.70	6130	27.0			54-2	F3C2254				
1.77	6360	28.0	84-1	F3C2184			42-4	F3C2442		
1.89	6810	30.0	90-1	F3C2190	60-2	F3C2260				
2.02	7270	32.0	96-1	F3C2196			48-4	F3C2448		
2.08	7490	33.0			66-2	F3C2266				
2.15	7720	34.0	102-1	F3C21102						
2.27	8180	36.0	108-1	F3C21108	72-2	F3C2272	54-4	F3C2454	36-8	F3C2836
2.40	8630	38.0	114-1	F3C21114						
2.46	8860	39.0			78-2	F3C2278				
2.52	9080	40.0					60-4	F3C2460		
2.65	9540	42.0			84-2	F3C2284			42-8	F3C2842
2.78	9990	44.0					66-4	F3C2466		
2.84	10200	45.0			90-2	F3C2290				
3.03	10900	48.0			96-2	F3C2296	72-4	F3C2472	48-8	F3C2848
3.22	11600	51.0			102-2	F3C22102				
3.28	11800	52.0					78-4	F3C2478		
3.41	12300	54.0			108-2	F3C22108			54-8	F3C2854
3.53	12700	56.0					84-4	F3C2484		
3.60	12900	57.0			114-2	F3C22114				
3.79	13600	60.0					90-4	F3C2490	60-8	F3C2860
4.04	14500	64.0					96-4	F3C2496		
4.16	15000	66.0							66-8	F3C2866
4.29	15400	68.0					102-4	F3C24102		
4.54	16400	72.0					108-4	F3C24108	72-8	F3C2872
4.79	17300	76.0					114-4	F3C24114		
4.92	17700	78.0							78-8	F3C2878
5.30	19100	84.0							84-8	F3C2884
5.68	20400	90.0							90-8	F3C2890
6.06	21800	96.0							96-8	F3C2896
6.44	23200	102							102-8	F3C28102
6.81	24500	108							108-8	F3C28108
7.19	25900	114							114-8	F3C28114

Accuracy: ±5% of controlled flow rate.



# Stainless Steel Inserts

## 80mm (3") Stainless Steel Inserts for DN50-DN1000 Valves

80mm · 3" · stainless steel insert										
Pressure range, ΔP:			10-135 kPaD 1-20 psid		22-210 kPaD 2-32 psid		40-390 kPaD 4-57 psid		90-880 kPaD 8-128 psid	
l/sec	l/hr	GPM	Type 1		Type 2		Type 4		Type 8	
			Marking	FlowCon	Marking	FlowCon	Marking	FlowCon	Marking	FlowCon
0.883	3180	14.0	35-1	F324135						
1.01	3630	16.0	40-1	F324140						
1.10	3970	17.5			35-2	F324235				
1.14	4090	18.0	45-1	F324145						
1.26	4540	20.0	50-1	F324150	40-2	F324240				
1.39	5000	22.0	55-1	F324155						
1.42	5110	22.5			45-2	F324245				
1.47	5300	23.3					35-4	F324435		
1.51	5450	24.0	60-1	F324160						
1.58	5680	25.0			50-2	F324250				
1.64	5910	26.0	65-1	F324165						
1.68	6060	26.7					40-4	F324440		
1.73	6250	27.5			55-2	F324255				
1.77	6360	28.0	70-1	F324170						
1.89	6810	30.0	75-1	F324175	60-2	F324260	45-4	F324445		
2.02	7270	32.0	80-1	F324180						
2.05	7380	32.5			65-2	F324265				
2.10	7570	33.3					50-4	F324450		
2.15	7720	34.0	85-1	F324185						
2.21	7950	35.0			70-2	F324270			35-8	F324835
2.27	8180	36.0	90-1	F324190						
2.31	8330	36.7					55-4	F324455		
2.37	8520	37.5			75-2	F324275				
2.40	8630	38.0	95-1	F324195						
2.52	9080	40.0	100-1	F3241100	80-2	F324280	60-4	F324460	40-8	F324840
2.65	9540	42.0	105-1	F3241105						
2.68	9650	42.5			85-2	F324285				
2.73	9840	43.3					65-4	F324465		
2.78	9990	44.0	110-1	F3241110						
2.84	10200	45.0			90-2	F324290			45-8	F324845
2.90	10400	46.0	115-1	F3241115						
2.94	10600	46.7					70-4	F324470		
3.00	10800	47.5			95-2	F324295				
3.03	10900	48.0	120-1	F3241120						
3.15	11400	50.0	125-1	F3241125	100-2	F3242100	75-4	F324475	50-8	F324850
3.28	11800	52.0	130-1	F3241130						
3.31	11900	52.5			105-2	F3242105				
3.36	12100	53.3					80-4	F324480		
3.41	12300	54.0	135-1	F3241135						
3.47	12500	55.0			110-2	F3242110			55-8	F324855
3.53	12700	56.0	140-1	F3241140						
3.58	12900	56.7					85-4	F324485		
3.63	13100	57.5			115-2	F3242115				
3.66	13200	58.0	145-1	F3241145						
3.79	13600	60.0	150-1	F3241150	120-2	F3242120	90-4	F324490	60-8	F324860
3.94	14200	62.5			125-2	F3242125				
4.00	14400	63.3					95-4	F324495		
4.10	14800	65.0			130-2	F3242130			65-8	F324865
4.21	15100	66.7					100-4	F3244100		
4.26	15300	67.5			135-2	F3242135				
4.42	15900	70.0			140-2	F3242140	105-4	F3244105	70-8	F324870
4.57	16500	72.5			145-2	F3242145				
4.63	16700	73.3					110-4	F3244110		
4.73	17000	75.0			150-2	F3242150			75-8	F324875
4.84	17400	76.7					115-4	F3244115		
5.05	18200	80.0					120-4	F3244120	80-8	F324880
5.26	18900	83.3					125-4	F3244125		
5.36	19300	85.0							85-8	F324885
5.47	19700	86.7					130-4	F3244130		
5.68	20400	90.0					135-4	F3244135	90-8	F324890
5.89	21200	93.3					140-4	F3244140		
5.99	21600	95.0							95-8	F324895
6.10	22000	96.7					145-4	F3244145		
6.31	22700	100					150-4	F3244150	100-8	F3248100
6.62	23800	105							105-8	F3248105
6.94	25000	110							110-8	F3248110
7.26	26100	115							115-8	F3248115
7.57	27300	120							120-8	F3248120
7.89	28400	125							125-8	F3248125
8.20	29500	130							130-8	F3248130
8.52	30700	135							135-8	F3248135
8.83	31800	140							140-8	F3248140
9.15	32900	145							145-8	F3248145
9.46	34100	150							150-8	F3248150

Nominal flow rate



Accuracy: ±5% of controlled flow rate.

# Stainless Steel Inserts

## 80mm (3") Hi-capacity Stainless Steel Inserts for DN50-DN1000 Valves



80mm · 3" · hi-capacity stainless steel insert								
Nominal flow rate	Pressure range, ΔP:			28-135 kPaD 4-20 psid		55-210 kPaD 8-32 psid		
	l/sec	l/hr	GPM	Type 1		Type 2		
				Marking	FlowCon	Marking	FlowCon	
	5.68	20400	90.0	220-1	F3241220			
6.94	25000	110	270-1	F3241270	220-2		F3242220	
8.20	29500	130	320-1	F3241320				
8.52	30700	135				270-2		F3242270
10.1	36300	160				320-2		F3242320

Accuracy: ±5% of controlled flow rate.

## 80mm (3") Hi-flow Stainless Steel Inserts for DN150-DN1000 Valves



80mm · 3" · hi-flow stainless steel insert										
Nominal flow rate	Pressure range, ΔP:			20-125 kPaD 3-18 psid		35-220 kPaD 5-32 psid		55-220 kPaD 8-32 psid		
	l/sec	l/hr	GPM	Type 3		Type 5		Type 6		
				Marking	FlowCon	Marking	FlowCon	Marking	FlowCon	
	6.31	22700	100	100-3	F117100					
8.52	30700	135			135-5	F118135				
10.1	36300	160			160-5	F118160				
12.6	45400	200			200-5	F118200				
18.9	68100	300						300-8	F119300	

Accuracy: ±5% of controlled flow rate.

For latest updates please see [www.flowcon.com](http://www.flowcon.com)

**FlowCon**  
international

A Griswold Controls LLC./FlowCon International Company

[www.flowcon.com](http://www.flowcon.com)

D E N M A R K · D U B A I · U S A · S I N G A P O R E

# FlowCon Green 15-40mm

## Pressure Independent Control Valves



### SPECIFICATIONS

#### **Insert:**

Static pressure:	2500 kPa / 360 psi
Ambient temperature:	+1°C to +50°C / +34°F to +122°F
Media temperature <sup>1</sup> :	-20°C to +120°C / -4°F to +248°F
Material:	
- Insert:	Glass-reinforced PSU/POM/PPS
- Diaphragm:	Green insert 20mm: EPDM Green insert 40mm: Hydrogenated acrylonitrile-butadiene-rubber
- Internal metal components:	Stainless steel
- O-rings:	EPDM
- Cone:	Green insert 20mm: PPS Green insert 40mm: PPS/EPDM
Maximum close off pressure:	Green insert 20mm: 600 kPaD / 87 psid Green insert 40mm: 400 kPaD / 58 psid
Maximum operational $\Delta P$ :	400 kPaD / 58 psid
Shut-off leakage:	ANSI / FCI 70-2 2006 / IEC 60534-4 - Class IV
Flow rate range:	Green insert 20mm: 0.0103-0.308 l/sec / 0.163-4.89 GPM Green insert 40mm: 0.240-1.29 l/sec / 3.81-20.4 GPM

#### **Valve:**

Material:	
- Body:	Forged brass ASTM CuZn40Pb2
- Ball valve:	ABV: Chemically nickel plated brass ball
End connections:	A: (only available for Green insert 20mm) Fixed female ISO or NPT AB: Fixed female ISO or NPT ABV: Union end connection in brass alloy ISO or NPT.

Note 1: Stated temperature rating is defined due to no external insert condensation.

## SPECIFICATIONS (...continued)

### FlowCon Actuators:

FlowCon Actuator <sup>2</sup>	FT.0.2 <sup>3</sup>	FT.0.3 <sup>3</sup>	FT.0.4 <sup>3</sup>
Supply voltage	24V AC -10%... +20%, 50/60Hz	230V AC ±10%, 50/60Hz	24V AC/DC -10%... +20%, 50/60Hz
Type	Thermal	Thermal	Thermal
Power consumption	1.2W	1.2W	1.2W
Control signal	Analog 0-10V, Normally closed	ON/OFF, Normally closed	ON/OFF, Normally closed
Failsafe function	Yes	Yes	Yes
Operation time <sup>4</sup>	App. 3.5 minutes	App. 4.5 minutes	App. 4.5 minutes
Ambient temperature	0°C to +60°C	0°C to +60°C	0°C to +60°C
Protection	IP54 including upside-down, class III	IP54 including upside-down, class II	IP54 including upside-down, class III
Cable	Plug-in, 1 meter	Fixed, 1 meter	Fixed, 1 meter
Weight	0.12 kg	0.11 kg	0.11 kg

Note 2: FlowCon warranty is voided using other actuators than supplied by FlowCon International.

Note 3: Please note if mounted on FlowCon Green.2 specified leakage rate to be exceeded.

Note 4: Closing time is approximately the double dependent on ambient temperature.

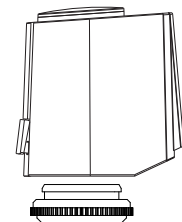

FlowCon FT.0.2

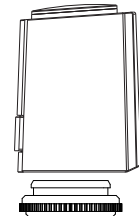

FlowCon FT.0.3/0.4

FlowCon Actuator <sup>5</sup>	FN.0.2	FN.0.3	FN.0.4
Supply voltage	24V AC/DC ±10%, 50/60 Hz	110/230V AC ±10%, 50/60 Hz	24V AC/DC ±10%, 50/60 Hz
Type	Electrical, Bi-directional synchronous motor		
Power consumption	5VA		
Control signal	Analog 0(2)-10V DC	Digital (2-position / 3-point floating)	Digital (2-position / 3-point floating)
Feedback	Yes, 0(2)-10V DC	No	No
Failsafe function	No	No	No
Auto stroke	Yes	No	No
Operation time	50 Hz: 18.5 sec/mm		
Ambient temperature	-18°C to +50°C		
Humidity rating	<95% no condensation		
Protection	IP54, class II		
Cable	Fixed, 4 wires 22 AWG halogen free cable, 1 meter	Fixed, 3 wires 22 AWG halogen free cable, 1 meter	Fixed, 3 wires 22 AWG halogen free cable, 1 meter
Closing point adjustment	During operation the actuator will self-adjust according to the closing point of the valve		
Weight	0.25 kg		

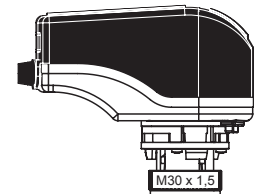

FlowCon FN.0.X

Note 5: FlowCon warranty is voided using other actuators than supplied by FlowCon International.

FlowCon Actuator <sup>6</sup>	FN.1.2	FN.1.4
Supply voltage	24V AC/DC ±10%, 50/60 Hz	
Type	Electrical, Bi-directional synchronous motor	
Power consumption	6VA, 10VA peaks	
Control signal	Analog 0(2)-10V DC	Digital (2-position / 3-point floating)
Feedback	Yes, 0(2)-10V DC	No
Failsafe function	Yes	Yes
Auto stroke	Yes	No
Operation time	50 Hz: 19 sec/mm	50 Hz: 18.5 sec/mm
Ambient temperature	-18°C to +50°C	
Humidity rating	<95% no condensation	
Protection	IP54, class II	
Cable	Fixed, 4 wires 22 AWG halogen free cable, 1 meter	
Closing point adjustment	During operation the actuator will self-adjust according to the closing point of the valve	
Weight	0.30 kg	

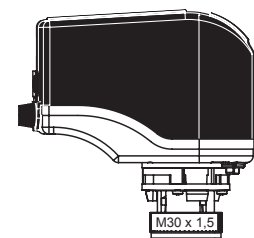

FlowCon FN.1.X

Note 6: FlowCon warranty is voided using other actuators than supplied by FlowCon International.

## DIMENSIONS AND WEIGHTS (NOMINAL) (measured in mm unless noted)

Model no.	Valve model	Valve size	Insert size	L	H1	H2 FT.0.2 act.	H3 FT.0.3/0.4 act.	H4 FN.0.X act.	H5 FN.1.X act.	End connections C <sup>7</sup>			Weight <sup>8</sup> (kgs.)	Kv <sup>9</sup> (m <sup>3</sup> /hr)
										ISO female	ISO male	Sweat		
G.X.XX.04	A	15	20	80	31	118	116	130	145	-	-	-	0.58	3.1
G.X.XX.05		20											0.53	
G.X.XX.06		25											0.56	
G.X.XX.01	AB	15	20	82	31	118	116	130	145	-	-	-	0.51	3.1
G.X.XX.02		20											0.56	
G.X.XX.07		25											0.62	
G.2.XX.14		25											1.85	
G.2.XX.15	32	1.69												
G.X.XX.03	ABV1	15	20	122	33	118	116	130	145	22	24	20	0.85	3.1
		20								22	25	20		
		25								-	39	22		
G.2.XX.17	ABV2	25	40	162	42	138	137	153	165	35	40	34	2.15	11.7
		32								33	40	34		
		40								33	42	-		

Note 7: Add end connection length to body length.  
 Note 8: Weight does not include end connections or actuator.  
 Note 9: For valve body.

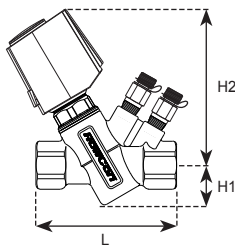

FlowCon AB DN15/20/25  
with FlowCon FT.0.2 actuator

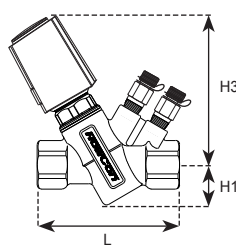

FlowCon AB DN15/20/25  
with FlowCon FT.0.3/0.4 act.

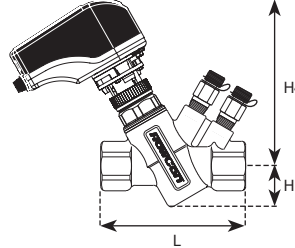

FlowCon AB DN15/20/25  
with FlowCon FN.0.X actuator

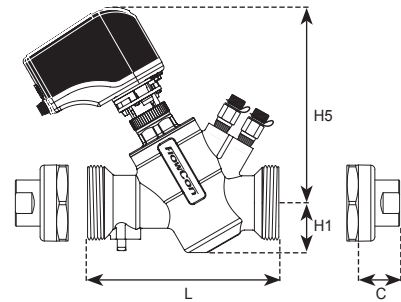

FlowCon ABV DN25/32/40  
with FlowCon FN.1.X actuator

## MODEL NUMBER SELECTION

Insert flow range:  
**0**=20mm insert low flow  
**1**=20mm insert medium flow  
**2**=40mm insert

Insert type of actuator:  
**22**=FT.0.2   **23**=FT.0.3   **24**=FT.0.4  
**32**=FN.0.2   **33**=FN.0.3   **34**=FN.0.4   **42**=FN.1.2   **44**=FN.1.4

Insert type of body:  
 20mm insert: **01**=AB15   **02**=AB20   **03**=ABV1   **04**=A15   **05**=A20   **06**=A25   **07**=AB25  
 40mm insert: **14**=AB25   **15**=AB32   **17**=ABV2

Insert p/t plug requirements:  
**B**=pressure/temperature plugs   **P**=taps plugged   - leave blank if A-body or no p/t plugs required

Insert inlet x outlet union end connections:   - leave blank if A- or AB-body or no end connections required

Body model and size	Female threaded	Male treaded	Sweat
G.0.XX.03, 15-25mm, 1/2"-1" G.1.XX.03, 15-25mm, 1/2"-1"	<b>E</b> = 15mm=1/2" <b>F</b> = 20mm=3/4"	<b>H</b> = 15mm=1/2" <b>I</b> = 20mm=3/4" <b>J</b> = 25mm=1"	<b>K</b> = 15mm <b>L</b> = 18mm <b>M</b> = 22mm
G.2.XX.17, 25-40mm, 1"-1 1/2"	<b>G</b> = 25mm=1" <b>P</b> = 32mm=1 1/4" <b>Q</b> = 40mm=1 1/2"	<b>J</b> = 25mm=1" <b>S</b> = 32mm=1 1/4" <b>T</b> = 40mm=1 1/2"	<b>N</b> = 28mm <b>W</b> = 35mm

Insert connections standard:  
**I**=ISO   **N**=NPT (NPT: not available on A25 and AB25 for 20mm insert)

Example: G.1.22.03.B.F.F.I=20mm FlowCon Green, medium flow, with an ABV1-body with p/t plugs and a 24V thermal modulating actuator and 20mm ISO female union end connections.

## WIRING INSTRUCTION

### FlowCon FT.0.2

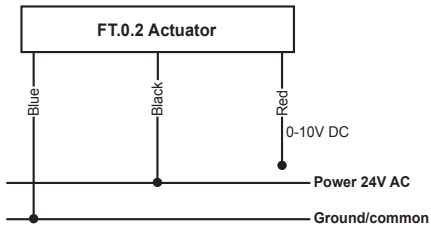

### FlowCon FT.0.3 and FT.0.4

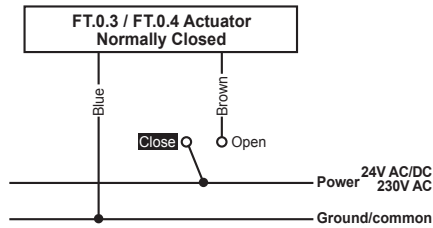

### FlowCon FN.0.2 and FN.1.2

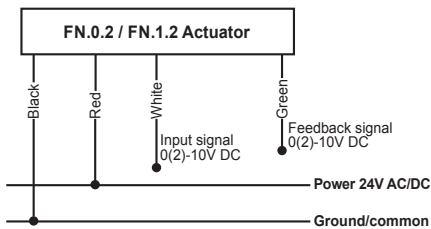

### FlowCon FN.0.3

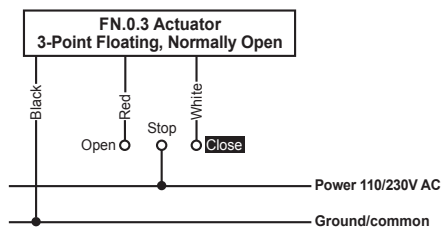
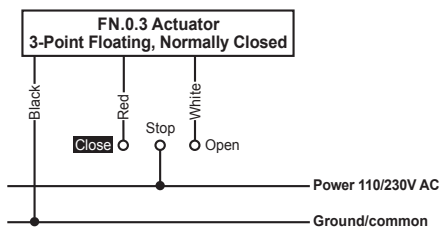
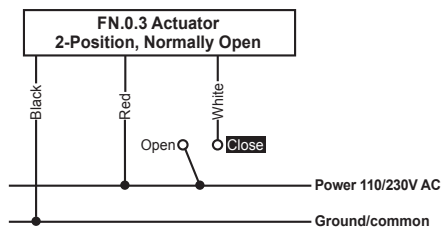
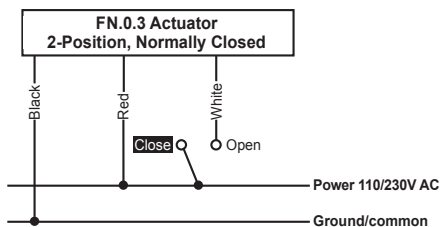

### FlowCon FN.0.4

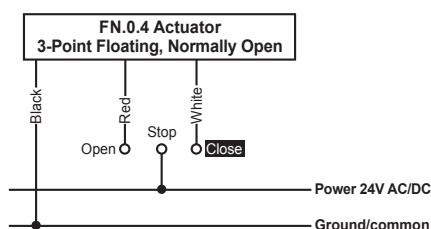
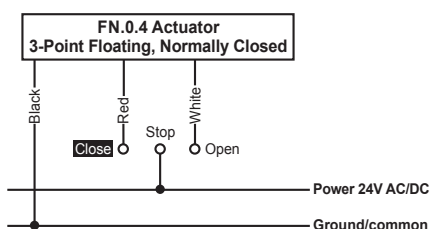
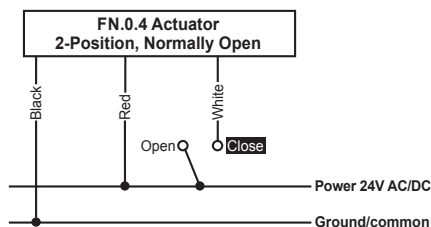
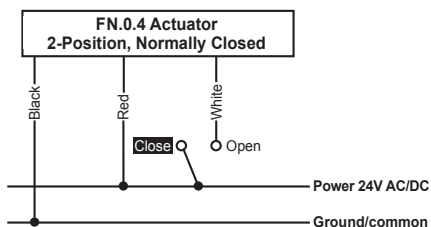

## WIRING INSTRUCTION (...continued)

### FlowCon FN.1.4

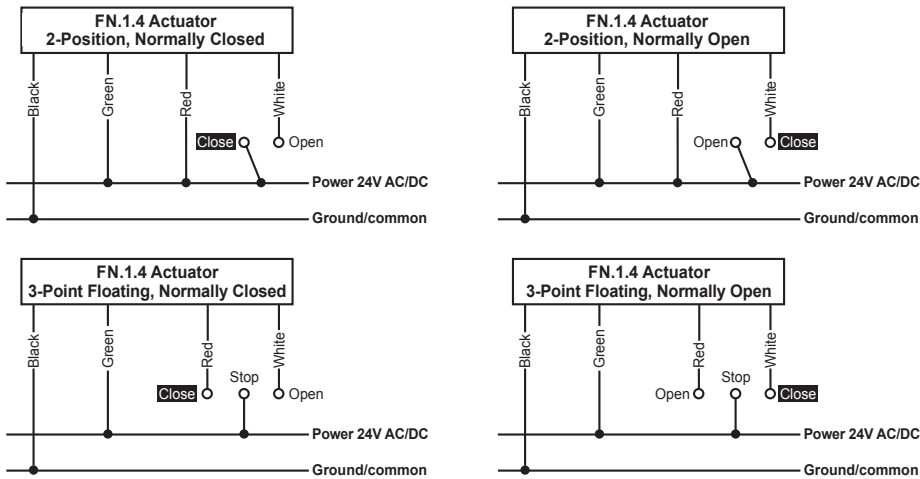

## DESCRIPTION

The FlowCon Green series is pressure independent control valves that are two-way, modulating to accept digital or analog input signals. The valves accept 0(2)-10V, 3-point floating or ON/OFF input signals. Each valve has an adjustable maximum flow rate setting maintaining a full stroke to enable flow limitation and balancing to the coil or zone that the valve is controlling.

For use in fan-coil units, VAV applications and cooling ceilings for activation of the heating or cooling. They are available in three different valve bodies, i.e. FlowCon A, AB or ABV.

## MAXIMUM FLOW RATE LIMITATION SETTINGS - VALVE SIZE DN15-DN40

FlowCon Green									
Insert size: 20mm · 3/4"						Insert size: 40mm · 1 1/2"			Setting
16-200 kPad · 2.3-29 psid			30-400 kPad · 4.4-58 psid			16-400 kPad · 2.3-58 psid (at setting: 2.6)			
FlowCon Green.0 (grey o-ring)			FlowCon Green.1 (black o-ring)			FlowCon Green.2 (black o-ring)			
l/sec	l/hr	GPM	l/sec	l/hr	GPM	l/sec	l/hr	GPM	
-	-	-	0.0178	64	0.282	0.240	865	3.81	1.0
0.0103	37	0.163	0.0393	142	0.624	0.282	1010	4.46	1.1
0.0233	84	0.370	0.0580	209	0.920	0.322	1160	5.10	1.2
0.0322	116	0.510	0.0743	268	1.180	0.361	1300	5.72	1.3
0.0419	151	0.664	0.0887	319	1.41	0.399	1430	6.32	1.4
0.0500	180	0.792	0.102	366	1.61	0.435	1570	6.90	1.5
0.0569	205	0.902	0.113	408	1.80	0.471	1700	7.47	1.6
0.0650	234	1.03	0.124	446	1.96	0.506	1820	8.02	1.7
0.0719	259	1.14	0.134	482	2.12	0.540	1940	8.56	1.8
0.0781	281	1.24	0.143	516	2.27	0.573	2060	9.08	1.9
0.0839	302	1.33	0.152	549	2.42	0.605	2180	9.59	2.0
0.0889	320	1.41	0.161	580	2.56	0.636	2290	10.1	2.1
0.0942	339	1.49	0.170	611	2.69	0.667	2400	10.6	2.2
0.0981	353	1.55	0.178	641	2.82	0.696	2510	11.0	2.3
0.103	371	1.63	0.186	671	2.95	0.725	2610	11.5	2.4
0.106	381	1.68	0.194	700	3.08	0.753	2710	11.9	2.5
0.109	394	1.73	0.202	728	3.21	0.780	2810	12.4	2.6
0.113	406	1.79	0.210	756	3.33	0.807	2900	12.8	2.7
0.115	414	1.82	0.218	783	3.45	0.832	3000	13.2	2.8
0.119	428	1.88	0.225	810	3.56	0.858	3090	13.6	2.9
0.122	439	1.93	0.232	835	3.68	0.882	3180	14.0	3.0
0.125	449	1.98	0.239	860	3.79	0.906	3260	14.4	3.1
0.127	458	2.02	0.245	883	3.89	0.930	3350	14.7	3.2
0.130	468	2.06	0.252	906	3.99	0.953	3430	15.1	3.3
0.133	477	2.10	0.257	927	4.08	0.975	3510	15.5	3.4
0.135	486	2.14	0.263	946	4.17	0.997	3590	15.8	3.5
0.137	494	2.17	0.268	965	4.25	1.02	3670	16.1	3.6
0.140	503	2.21	0.273	982	4.32	1.04	3740	16.5	3.7
0.142	511	2.25	0.277	998	4.39	1.06	3820	16.8	3.8
0.144	518	2.28	0.281	1010	4.46	1.08	3890	17.1	3.9
0.146	526	2.31	0.285	1020	4.51	1.10	3960	17.4	4.0
0.148	532	2.34	0.288	1040	4.57	1.12	4030	17.7	4.1
0.149	538	2.37	0.291	1050	4.61	1.14	4100	18.1	4.2
0.151	544	2.39	0.294	1060	4.66	1.16	4170	18.4	4.3
0.153	549	2.42	0.296	1070	4.70	1.18	4240	18.7	4.4
0.154	553	2.43	0.299	1080	4.73	1.20	4300	19.0	4.5
0.155	559	2.46	0.301	1080	4.77	1.21	4370	19.2	4.6
0.156	563	2.48	0.303	1090	4.80	1.23	4440	19.5	4.7
0.158	567	2.50	0.305	1100	4.83	1.25	4500	19.8	4.8
0.159	571	2.51	0.307	1100	4.86	1.27	4570	20.1	4.9
0.160	575	2.53	0.308	1110	4.89	1.29	4630	20.4	5.0

Nominal flow rate

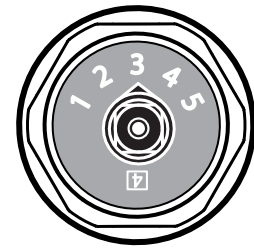

A micrometer setting of 3.4 as illustrated beside corresponds to a maximum flow rate of

0.133 l/sec (Green.0),  
0.257 l/sec (Green.1),  
0.975 l/sec (Green.2).

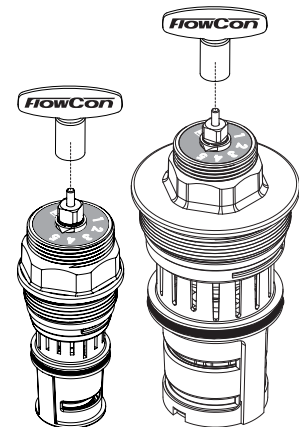

Use the special designed key (FlowCon part no. ACC0001) for micrometer setting.

Accuracy: Greatest of either ±10% of controlled flow rate or ±5% of maximum flow rate.

## GENERAL SPECIFICATIONS

### 1. PRESSURE INDEPENDENT DYNAMIC CONTROL VALVE FLOWCON GREEN

- 1.1. Contractor shall install the pressure independent dynamic control valves where indicated in drawings.
- 1.2. Valve shall be an electronic, dynamic, modulating, 2-way, pressure independent control device.
- 1.3. Pressure independent dynamic control valve shall accurately control flow, independent of system pressure fluctuation.
- 1.4. Maximum flow setting shall be adjustable to 41 different settings within the range of the valve size.

### 2. VALVE ACTUATOR

#### 2.a. FlowCon FT actuators

- 2.a.1. Valve actuator housing shall be rated to IP54, including up-side-down mounting.
- 2.a.2. Actuator shall be driven by 24V or 230V AC, and shall depending on actuator choice accept 0-10V DC or ON/OFF control signal.
- 2.a.3. Actuator shall use full stroke and provide full authority.
- 2.a.4. Actuator shall have visible indication of stroke position.
- 2.a.5. Failsafe function shall be available on all version.

OR...

#### 2.b. FlowCon FN actuators

- 2.b.1. Valve actuator housing shall be rated to IP54.
- 2.b.2. Actuator shall be driven by 24V AC/DC or 110V/230V AC, and shall depending on actuator choice accept 0(2)-10V DC, 3-point floating or 2-position control signal.
- 2.b.3. Actuator shall use full stroke and provide full authority.
- 2.b.4. Actuator shall have visible indication of stroke position.
- 2.b.5. Feedback signal 0(2)-10V DC to the control system shall be standard on modulating version.
- 2.b.6. Optional failsafe function shall be available on 24V AC/DC versions.
- 2.b.7. Optional auto stroke function shall be available on modulating version.
- 2.b.8. Manual override shall be possible without use of tools.

### 3. VALVE HOUSING

#### 3.a. FlowCon A

- 3.a.1. Valve housing shall consist of forged brass ASTM CuZn40Pb2, rated at no less than 2500 kPa static pressure at +120°C.

OR...

#### 3.b. FlowCon AB

- 3.b.1. Valve housing shall consist of forged brass ASTM CuZn40Pb2, rated at no less than 2500 kPa static pressure at +120°C.
- 3.b.2. Pressure/temperature test plugs for verifying accuracy of flow performance shall be available for all valve sizes.

OR...

#### 3.c. FlowCon ABV

- 3.c.1. Valve housing shall consist of forged brass ASTM CuZn40Pb2, rated at no less than 2500 kPa static pressure at +120°C.
- 3.c.2. Valve ball shall consist of chemically nickel plated brass (ASTM CuZn40Pb2).
- 3.c.3. Pressure/temperature test plugs for verifying accuracy of flow performance shall be available for all valve sizes.

### 4. FLOW REGULATION UNIT

- 4.1. Flow regulation unit shall consist of glass-reinforced PSU/POM/PPS with an EPDM diaphragm (20mm insert) or a hydrogenated acrylonitrile-butadiene-rubber diaphragm (40mm insert).
- 4.2. Flow regulation unit shall be readily accessible, for change-out or maintenance. Flow regulation unit shall be adjustable with the valve in-line and the system in operation.
- 4.3. Flow regulation unit shall be externally adjustable to 1 of 41 different flow rates without limiting the stroke length; shall be available in 2 different kPaD operational ranges for DN15/20/25 and 1 kPaD operational ranges for DN25/32/40; minimum range shall be capable of being activated by minimum 16 kPaD. Further, the flow regulation unit shall be capable of controlling the flow within  $\pm 10\%$  of rated flow or  $\pm 5\%$  of maximum flow.

## APPLICATION AND SCHEMATIC EXAMPLE

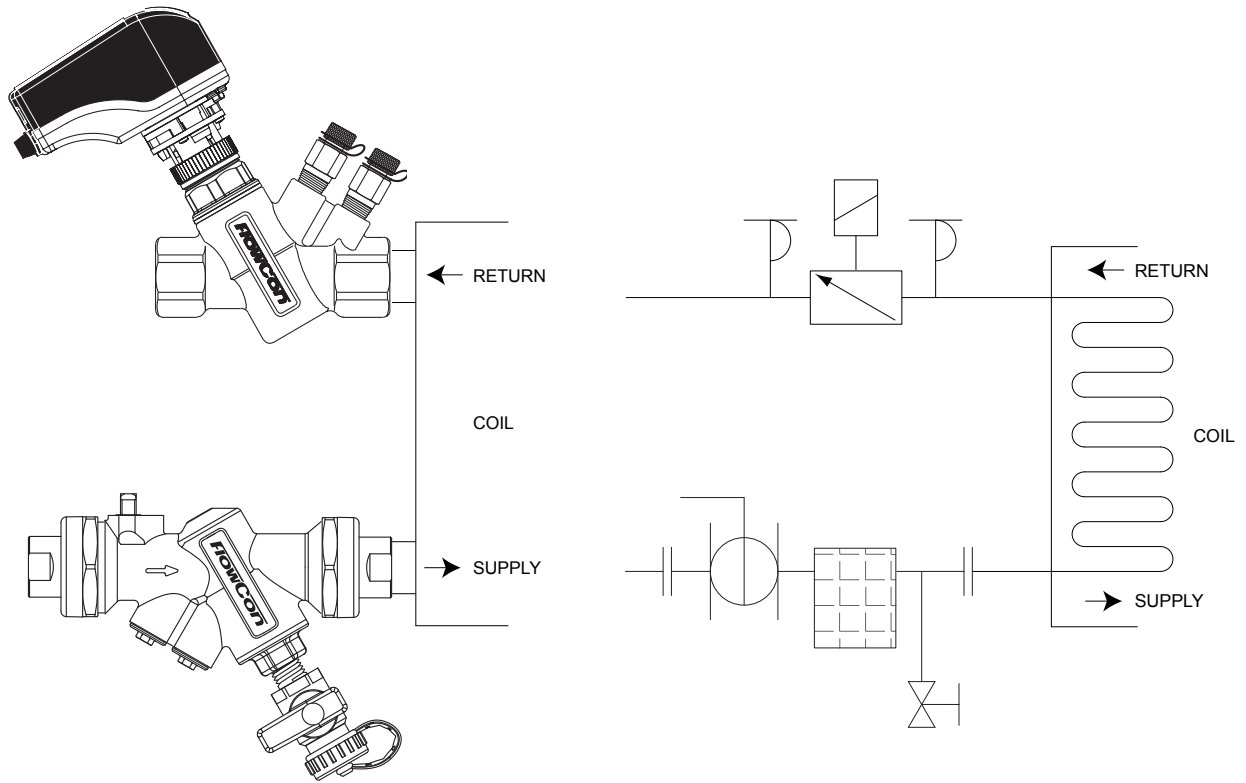

## UPDATES

**For latest updates please see [www.flowcon.com](http://www.flowcon.com)**

FlowCon International can accept no responsibility for possible errors in any printed material.  
All rights reserved.

# FlowCon E-JUST 20mm-50mm

## External Adjustable Composite Insert



### SPECIFICATIONS

Static pressure:	2500 kPa / 360 psi
Temperature rating, media:	-20°C to +120°C / -4°F to +248°F
Materials:	
- Insert:	PSU (Polysulfone)
- Diaphragm:	- Hydrogenated acrylonitrile-butadiene-rubber on G-red, G-green, G-black, 40mm Y-green and 50mm G-black - EPDM on Y-red, Y-green and Y-black
- Spring:	18-8 stainless steel
- Stem seals:	EPDM
- Head nut:	Forged brass ASTM CuZn40Pb2
Flow rate range:	0.0278-4.48 l/sec

## FLOW RATES ( $\pm 5\%$ of controlled flow or $\pm 2\%$ of maximum flow)

E-JUST model	Control range		Minimum setting			Maximum setting		
	kPaD	psid	l/sec	l/hr	GPM	l/sec	l/hr	GPM
20mm	17-200	2.5-29	0.0767	276	1.22	0.229	825	3.60
	17-210	2.5-30	0.0278	100	0.44	0.169	609	2.68
	30-400	4.4-58	0.113	406	1.79	0.352	1270	5.57
	35-400	5.1-58	0.0383	138	0.607	0.249	896	3.95
40mm	17-400	2.5-58	0.149	535	2.36	1.62	5830	25.7
50mm	20-400	2.9-58	0.883	3180	14.0	4.48	16100	70.9

## MODEL NUMBER SELECTION

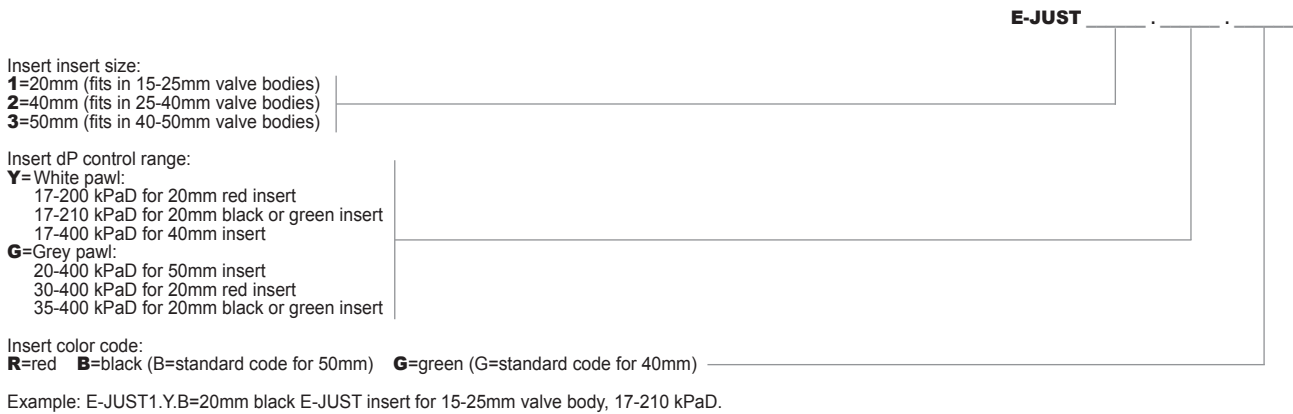

## FLOW RATE SETTING - E-JUST INSERT - FOR VALVES DN15-DN25 SMALL

20mm · 3/4" · E-JUST · Y-type · White pawl					
Pressure range, ΔP: 17-210 kPaD · 2.5-30 psid					
Nominal flow rate	Model no.			E-JUST1.Y.B	E-JUST1.Y.G
	l/sec	l/hr	GPM	Black	Green
				Setting	Setting
	0.0278	100	0.440	1.0	
	0.0299	108	0.475	1.1	
	0.0321	116	0.509	1.2	
	0.0343	123	0.543	1.3	
	0.0364	131	0.578	1.4	
	0.0386	139	0.612	1.5	
	0.0408	147	0.646	1.6	
	0.0429	155	0.681	1.7	
	0.0436	157	0.691		1.0
	0.0451	162	0.715	1.8	
	0.0468	168	0.741		1.1
	0.0473	170	0.749	1.9	
	0.0494	178	0.784	2.0	
	0.0499	180	0.791		1.2
	0.0516	186	0.818	2.1	
	0.0530	191	0.841		1.3
	0.0538	194	0.852	2.2	
	0.0559	201	0.887	2.3	
	0.0562	202	0.890		1.4
	0.0581	209	0.921	2.4	
	0.0593	214	0.940		1.5
	0.0603	217	0.955	2.5	
	0.0624	225	0.990	2.6	1.6
	0.0646	233	1.02	2.7	
	0.0656	236	1.04		1.7
	0.0668	240	1.06	2.8	
	0.0687	247	1.09		1.8
	0.0689	248	1.09	2.9	
	0.0711	256	1.13	3.0	
	0.0719	259	1.14		1.9
	0.0733	264	1.16	3.1	
	0.0750	270	1.19		2.0
	0.0754	272	1.20	3.2	
	0.0776	279	1.23	3.3	
	0.0781	281	1.24		2.1
	0.0798	287	1.26	3.4	
	0.0813	293	1.29		2.2
	0.0819	295	1.30	3.5	
	0.0841	303	1.33	3.6	
	0.0844	304	1.34		2.3
	0.0863	311	1.37	3.7	
	0.0876	315	1.39		2.4
	0.0884	318	1.40	3.8	

Continue next column...

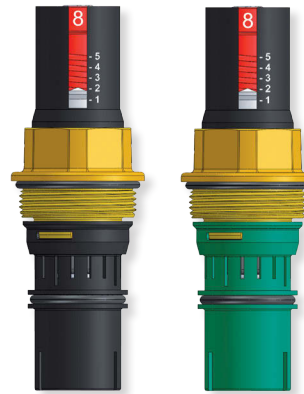

20mm · 3/4" · E-JUST · Y-type · White pawl					
Pressure range, ΔP: 17-210 kPaD · 2.5-30 psid					
Nominal flow rate	Model no.			E-JUST1.Y.B	E-JUST1.Y.G
	l/sec	l/hr	GPM	Black	Green
				Setting	Setting
	0.0906	326	1.44	3.9	
	0.0907	327	1.44		2.5
	0.0928	334	1.47	4.0	
	0.0938	338	1.49		2.6
	0.0949	342	1.50	4.1	
	0.0970	349	1.54		2.7
	0.0971	350	1.54	4.2	
	0.0993	357	1.57	4.3	
	0.100	360	1.59		2.8
	0.101	365	1.61	4.4	
	0.103	372	1.64		2.9
	0.104	373	1.64	4.5	
	0.106	381	1.68	4.6	
	0.106	383	1.69		3.0
	0.108	389	1.71	4.7	
	0.110	394	1.74		3.1
	0.110	396	1.75	4.8	
	0.112	404	1.78	4.9	
	0.113	406	1.79		3.2
	0.114	412	1.81	5.0	
	0.116	417	1.84		3.3
	0.119	428	1.89		3.4
	0.122	440	1.94		3.5
	0.125	451	1.98		3.6
	0.128	462	2.03		3.7
	0.132	473	2.08		3.8
	0.135	485	2.13		3.9
	0.138	496	2.18		4.0
	0.141	507	2.23		4.1
	0.144	519	2.28		4.2
	0.147	530	2.33		4.3
	0.150	541	2.38		4.4
	0.153	553	2.43		4.5
	0.157	564	2.48		4.6
	0.160	575	2.53		4.7
	0.163	586	2.58		4.8
	0.166	598	2.63		4.9
	0.169	609	2.68		5.0

Accuracy: Greatest of either ±5% of controlled flow rate or ±2% of maximum flow rate

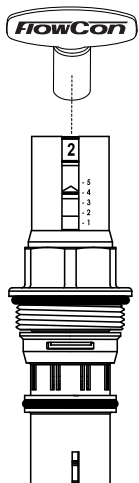

Use the FlowCon adjustment key (part number ACC0001) for adjusting the flow rate.

A setting of 4.2 corresponds to a flow rate of 0.144 l/sec for the 20mm green insert, range 17-210 kPaD.

## FLOW RATE SETTING - E-JUST INSERT - FOR VALVES DN15-DN25 SMALL (continued)

20mm · 3/4" · E-JUST · Y-type · White pawl				
Pressure range. ΔP: 17-200 kPaD · 2.5-29 psid				
	Model no.			E-JUST1.Y.R
	l/sec	l/hr	GPM	Red
				Setting
Nominal flow rate	0.0767	276	1.22	1.0
	0.0813	293	1.29	1.1
	0.0860	310	1.36	1.2
	0.0907	326	1.44	1.3
	0.0953	343	1.51	1.4
	0.100	360	1.58	1.5
	0.105	377	1.66	1.6
	0.109	393	1.73	1.7
	0.114	410	1.80	1.8
	0.118	426	1.88	1.9
	0.123	443	1.95	2.0
	0.128	459	2.02	2.1
	0.132	475	2.09	2.2
	0.136	491	2.16	2.3
	0.141	507	2.23	2.4
	0.145	523	2.30	2.5
	0.150	539	2.37	2.6
	0.154	554	2.44	2.7
	0.158	569	2.51	2.8
	0.162	584	2.57	2.9
	0.166	599	2.64	3.0
	0.170	614	2.70	3.1
	0.174	628	2.76	3.2
	0.178	642	2.83	3.3
	0.182	655	2.89	3.4
	0.186	669	2.94	3.5
	0.189	682	3.00	3.6
	0.193	695	3.06	3.7
	0.196	707	3.11	3.8
	0.200	719	3.17	3.9
0.203	731	3.22	4.0	
0.206	742	3.27	4.1	
0.209	753	3.32	4.2	
0.212	764	3.36	4.3	
0.215	774	3.41	4.4	
0.218	784	3.45	4.5	
0.220	793	3.49	4.6	
0.223	802	3.53	4.7	
0.225	810	3.57	4.8	
0.227	818	3.60	4.9	
0.229	825	3.60	5.0	

Accuracy: Greatest of either ±5% of controlled flow rate or ±2% of maximum flow rate

20mm · 3/4" · E-JUST · G-type · Grey pawl				
Pressure range. ΔP: 30-400 kPaD · 4.4-58 psid				
	Model no.			E-JUST1.G.R
	l/sec	l/hr	GPM	Red
				Setting
Nominal flow rate	0.113	406	1.79	1.0
	0.119	427	1.88	1.1
	0.125	449	1.98	1.2
	0.131	470	2.07	1.3
	0.137	492	2.17	1.4
	0.143	513	2.26	1.5
	0.149	535	2.36	1.6
	0.155	556	2.45	1.7
	0.161	578	2.54	1.8
	0.167	599	2.64	1.9
	0.172	621	2.73	2.0
	0.178	642	2.83	2.1
	0.184	664	2.92	2.2
	0.190	685	3.02	2.3
	0.196	707	3.11	2.4
	0.202	728	3.21	2.5
	0.208	750	3.30	2.6
	0.214	771	3.40	2.7
	0.220	793	3.49	2.8
	0.226	814	3.59	2.9
	0.232	836	3.68	3.0
	0.238	857	3.78	3.1
	0.244	879	3.87	3.2
	0.250	900	3.96	3.3
	0.256	922	4.06	3.4
	0.262	943	4.15	3.5
	0.268	965	4.25	3.6
	0.274	987	4.34	3.7
	0.280	1010	4.44	3.8
	0.286	1030	4.53	3.9
0.292	1050	4.63	4.0	
0.298	1070	4.72	4.1	
0.304	1090	4.82	4.2	
0.310	1120	4.91	4.3	
0.316	1140	5.01	4.4	
0.322	1160	5.10	4.5	
0.328	1180	5.20	4.6	
0.334	1200	5.29	4.7	
0.340	1220	5.38	4.8	
0.346	1240	5.48	4.9	
0.352	1270	5.57	5.0	

Accuracy: Greatest of either ±5% of controlled flow rate or ±2% of maximum flow rate

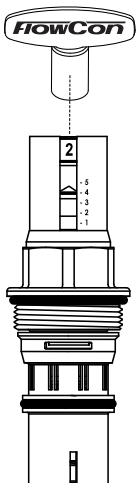
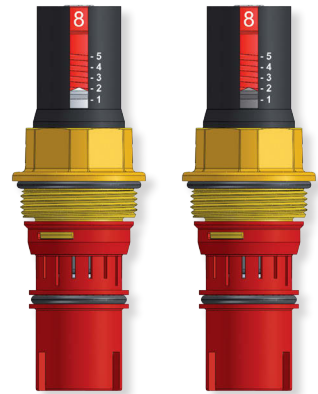

Use the FlowCon adjustment key (part number ACC0001) for adjusting the flow rate.

A setting of 4.2 corresponds to a flow rate of 0.304 l/sec for the 20mm red insert, range 30-400 kPaD.

**FLOW RATE SETTING - E-JUST INSERT - FOR VALVES DN15-DN25 SMALL (continued)**

20mm · 3/4" · E-JUST · G-type · Grey pawl					
Pressure range, ΔP: 35-400 kPaD · 5.1-58 psid					
Nominal flow rate	Model no.			E-JUST1.G.B	E-JUST1.G.G
	l/sec	l/hr	GPM	Black	Green
				Setting	Setting
	0.0383	138	0.607	1.0	
	0.0416	150	0.660	1.1	
	0.0449	162	0.712	1.2	
	0.0483	174	0.765	1.3	
	0.0516	186	0.817	1.4	
	0.0549	198	0.870	1.5	
	0.0582	210	0.922	1.6	
	0.0615	221	0.975	1.7	
	0.0648	233	1.03	1.8	
	0.0660	238	1.05		1.0
	0.0681	245	1.08	1.9	
	0.0706	254	1.12		1.1
	0.0714	257	1.13	2.0	
	0.0748	269	1.18	2.1	
	0.0751	271	1.19		1.2
	0.0781	281	1.24	2.2	
	0.0797	287	1.26		1.3
	0.0814	293	1.29	2.3	
	0.0843	304	1.34		1.4
	0.0847	305	1.34	2.4	
	0.0880	317	1.40	2.5	
	0.0889	320	1.41		1.5
	0.0913	329	1.45	2.6	
	0.0934	336	1.48		1.6
	0.0946	341	1.50	2.7	
	0.0979	353	1.55	2.8	
	0.0980	353	1.55		1.7
	0.101	365	1.61	2.9	
	0.103	369	1.63		1.8
	0.105	377	1.66	3.0	
	0.107	386	1.70		1.9
	0.108	388	1.71	3.1	
	0.111	400	1.76	3.2	
	0.112	402	1.77		2.0
	0.115	412	1.82	3.3	
	0.116	419	1.84		2.1
	0.118	424	1.87	3.4	
	0.121	435	1.92		2.2
	0.121	436	1.92	3.5	
	0.124	448	1.97	3.6	
	0.125	452	1.99		2.3
	0.128	460	2.03	3.7	
	0.130	468	2.06		2.4
	0.131	472	2.08	3.8	

Continue next column...

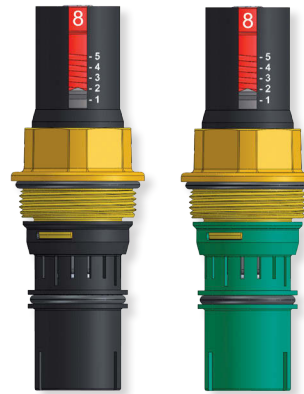

20mm · 3/4" · E-JUST · G-type · Grey pawl					
Pressure range, ΔP: 35-400 kPaD · 5.1-58 psid					
Nominal flow rate	Model no.			E-JUST1.G.B	E-JUST1.G.G
	l/sec	l/hr	GPM	Black	Green
				Setting	Setting
	0.134	484	2.13	3.9	
	0.135	485	2.13		2.5
	0.138	496	2.18	4.0	
	0.139	501	2.21		2.6
	0.141	508	2.24	4.1	
	0.144	517	2.28		2.7
	0.144	520	2.29	4.2	
	0.148	532	2.34	4.3	
	0.148	534	2.35		2.8
	0.151	544	2.39	4.4	
	0.153	550	2.42		2.9
	0.154	556	2.45	4.5	
	0.157	567	2.50		3.0
	0.158	567	2.50	4.6	
	0.161	579	2.55	4.7	
	0.162	583	2.57		3.1
	0.164	591	2.60	4.8	
	0.167	600	2.64		3.2
	0.168	603	2.66	4.9	
	0.171	615	2.71	5.0	
	0.171	616	2.71		3.3
	0.176	633	2.79		3.4
	0.180	649	2.86		3.5
	0.185	666	2.93		3.6
	0.189	682	3.00		3.7
	0.194	699	3.08		3.8
	0.199	715	3.15		3.9
	0.203	731	3.22		4.0
	0.208	748	3.29		4.1
	0.212	764	3.37		4.2
	0.217	781	3.44		4.3
	0.221	797	3.51		4.4
	0.226	814	3.58		4.5
	0.231	830	3.66		4.6
	0.235	847	3.73		4.7
	0.240	863	3.80		4.8
	0.244	880	3.87		4.9
	0.249	896	3.95		5.0

Accuracy: Greatest of either ±5% of controlled flow rate or ±2% of maximum flow rate

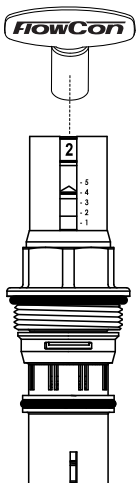

Use the FlowCon adjustment key (part number ACC0001) for adjusting the flow rate.

A setting of 4.2 corresponds to a flow rate of 0.212 l/sec for the 20mm green insert, range 35-400 kPaD.

## FLOW RATE SETTING - E-JUST INSERT - FOR VALVES DN25 LARGE-DN40

40mm · 1 1/2" · E-JUST · Y-type · White pawl				
Pressure range. ΔP: 17-400 kPaD · 2.5-58 psid				
Model no. E-JUST2.Y.G				
Nominal flow rate	l/sec	l/hr	GPM	Setting
	0.149	535	2.36	1.0
	0.220	793	3.49	1.1
	0.289	1040	4.58	1.2
	0.355	1280	5.63	1.3
	0.418	1510	6.63	1.4
	0.479	1730	7.60	1.5
	0.538	1940	8.52	1.6
	0.594	2140	9.41	1.7
	0.647	2330	10.3	1.8
	0.699	2520	11.1	1.9
	0.748	2690	11.9	2.0
	0.795	2860	12.6	2.1
	0.841	3030	13.3	2.2
	0.884	3180	14.0	2.3
	0.925	3330	14.7	2.4
	0.965	3470	15.3	2.5
	1.00	3610	15.9	2.6
	1.04	3740	16.5	2.7
	1.07	3870	17.0	2.8
1.11	3990	17.6	2.9	
1.14	4100	18.1	3.0	
1.17	4220	18.6	3.1	
1.20	4320	19.0	3.2	
1.23	4420	19.5	3.3	
1.26	4520	19.9	3.4	
1.28	4620	20.3	3.5	
1.31	4710	20.7	3.6	
1.33	4800	21.1	3.7	
1.36	4890	21.5	3.8	
1.38	4970	21.9	3.9	
1.40	5050	22.3	4.0	
1.43	5130	22.6	4.1	
1.45	5210	23.0	4.2	
1.47	5290	23.3	4.3	
1.49	5370	23.6	4.4	
1.51	5440	24.0	4.5	
1.53	5520	24.3	4.6	
1.55	5600	24.6	4.7	
1.58	5670	25.0	4.8	
1.60	5750	25.3	4.9	
1.62	5830	25.7	5.0	

Accuracy: Greatest of either ±5% of controlled flow rate or ±2% of maximum flow rate

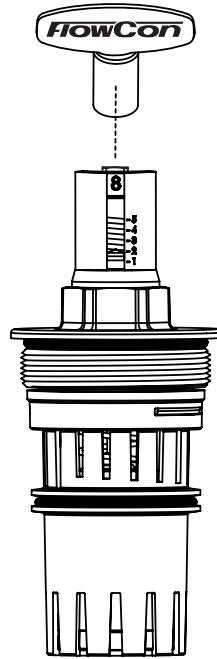
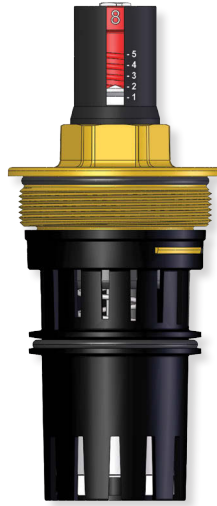

Use the FlowCon adjustment key (part number ACC0001) for adjusting the flow rate.

A setting of 4.2 corresponds to a flow rate of 1.45 l/sec for the 40mm insert, range 17-400 kPaD.

## FLOW RATE SETTING - E-JUST INSERT - FOR VALVES DN40/50

50mm · 2" · E-JUST · G-type · Grey pawl				
Pressure range. ΔP: 20-400 kPaD · 2.9-58 psid				
Model no. E-JUST3.G.B				
Nominal flow rate	l/sec	l/hr	GPM	Setting
	0.883	3180	14.0	1.0
	1.14	4100	18.0	1.1
	1.37	4940	21.7	1.2
	1.59	5710	25.1	1.3
	1.78	6420	28.3	1.4
	1.96	7070	31.1	1.5
	2.13	7660	33.7	1.6
	2.28	8200	36.1	1.7
	2.42	8700	38.3	1.8
	2.54	9150	40.3	1.9
	2.66	9570	42.1	2.0
	2.77	9960	43.8	2.1
	2.86	10300	45.4	2.2
	2.95	10600	46.8	2.3
	3.04	10900	48.2	2.4
	3.12	11200	49.4	2.5
	3.19	11500	50.6	2.6
	3.26	11700	51.7	2.7
	3.32	12000	52.7	2.8
	3.39	12200	53.7	2.9
	3.45	12400	54.6	3.0
	3.51	12600	55.6	3.1
	3.56	12800	56.5	3.2
	3.62	13000	57.3	3.3
	3.67	13200	58.2	3.4
3.73	13400	59.1	3.5	
3.78	13600	59.9	3.6	
3.83	13800	60.8	3.7	
3.89	14000	61.6	3.8	
3.94	14200	62.4	3.9	
3.99	14400	63.3	4.0	
4.05	14600	64.1	4.1	
4.10	14800	65.0	4.2	
4.15	14900	65.8	4.3	
4.20	15100	66.6	4.4	
4.25	15300	67.4	4.5	
4.30	15500	68.2	4.6	
4.35	15700	68.9	4.7	
4.39	15800	69.6	4.8	
4.44	16000	70.3	4.9	
4.48	16100	70.9	5.0	

Accuracy: Greatest of either ±5% of controlled flow rate or ±2% of maximum flow rate

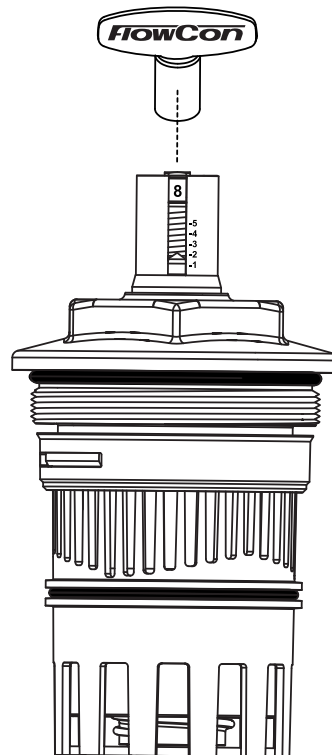
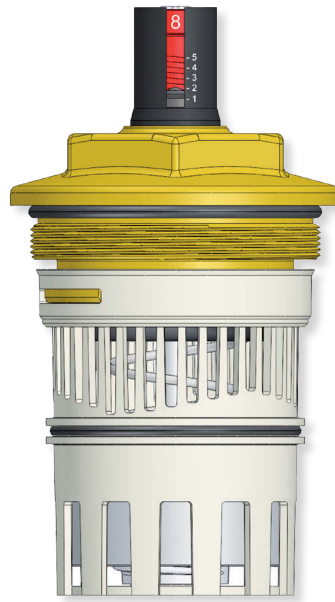

Use the FlowCon adjustment key (part number ACC0001) for adjusting the flow rate.

A setting of 4.2 corresponds to a flow rate of 4.10 l/sec for the 50mm insert, range 20-400 kPaD.

## GENERAL DESCRIPTION

The FlowCon E-JUST insert is tamper-proof since the adjustment unit is being operated by means of a special FlowCon key and the setting can be sealed by means of a colored top cover. The color of the cover indicates the color of the insert, i.e. the flow range. The color of the pawl on the handle shows the control range. The FlowCon E-JUST can be used with the following FlowCon valves:

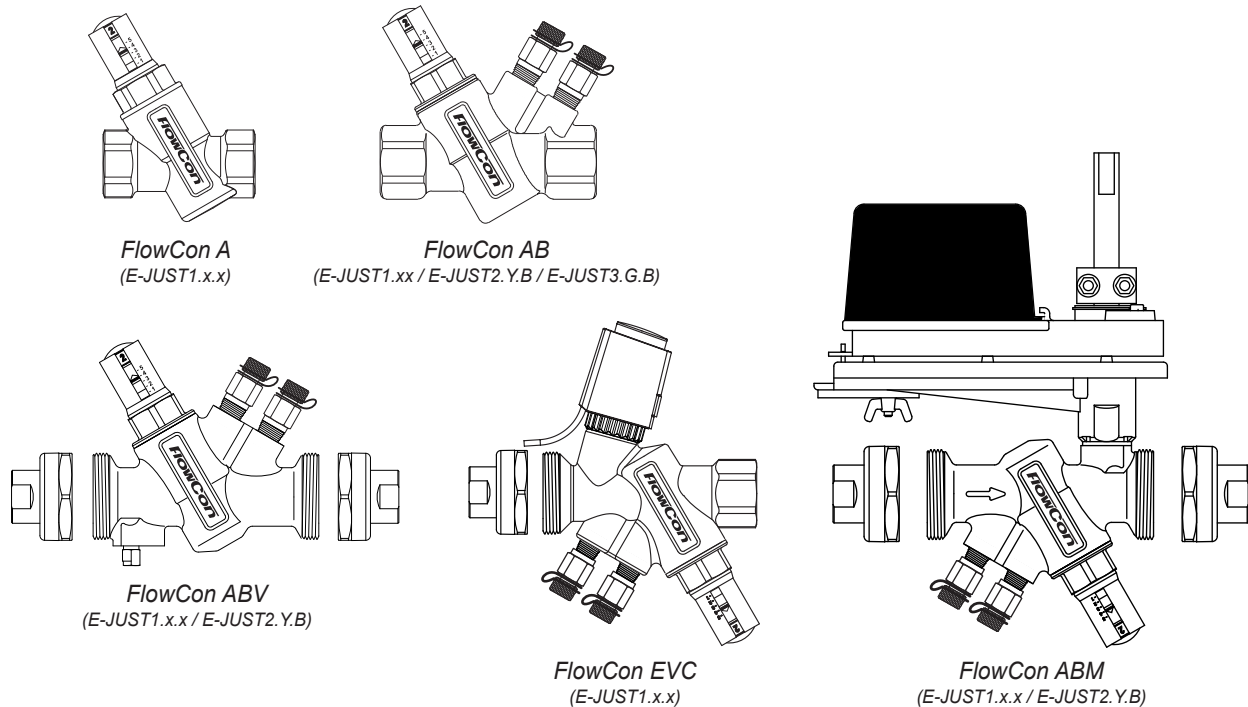

## GENERAL SPECIFICATIONS

- 1. AUTOMATIC BALANCING VALVES WITH EXTERNAL ADJUSTABLE INSERT**
  - 1.1. Contractor shall install automatic balancing valves where indicated in drawings.
  - 1.2. Valve shall consist of dynamic, adjustable flow limiting device.
  - 1.3. Housing shall be configured for flow regulation unit accessibility.
- 2. FLOW REGULATOR / AUTOMATIC BALANCING UNIT**
  - 2.1. Flow regulation unit assembly shall be manufactured of polysulfone with a hydrogenated acrylonitrile-butadiene rubber or EPDM diaphragm and stainless steel 18-8 spring.
  - 2.2. Flow regulation unit shall be readily accessible for change-out or maintenance.
  - 2.3. Flow regulation unit shall be adjustable with the valve in-line and the system in operation.
  - 2.4. Flow regulation unit shall be externally adjustable to 1 of 41 different flow rates; shall be available in 4 different kPaD operational ranges for DN15/20/25, 1 kPaD operational range for DN25/32/40 and 1 kPaD operational range for DN40/50; minimum range shall be capable of being activated by minimum 17 kPaD. Further, the flow regulation unit shall be capable of controlling flow within  $\pm 5\%$  of rated flow or  $\pm 2\%$  of maximum flow.
  - 2.5. Identification tags shall be available for all inserts; tags shall be indelibly marked with differential pressure range, flow rate, color and dial setting.

## UPDATES

For latest updates please see [www.flowcon.com](http://www.flowcon.com)

FlowCon International can accept no responsibility for possible errors in any printed material. All rights reserved.

# FlowCon SDP 15-25mm

## Simple Differential Pressure Control Valve

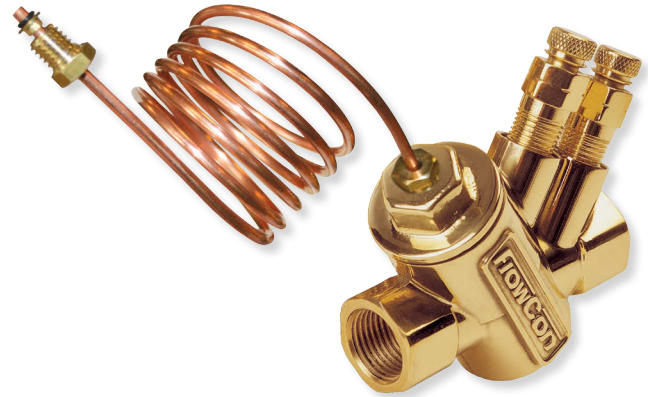

### SPECIFICATIONS

#### SDP insert:

Static pressure:	2500 kPa / 360 psi
Temperature rating, media:	-20°C to +120°C / -4°F to +248°F
Material:	
- Inserts:	Glass-reinforced PPS/POM
- Diaphragm:	EPDM
- O-rings:	EPDM
Maximum operational $\Delta P$ :	400 kPaD / 58 psid
Controlled $\Delta P$ :	FlowCon SDP 10: 10 kPaD FlowCon SDP 20: 20 kPaD FlowCon SDP 30: 30 kPaD

#### Valve:

Material:	
- Body:	Forged brass ASTM CuZn40Pb2 / DZR CuZn36pb2As
- Ball valve:	FlowCon ABV: Chemically nickel plated brass ball
End connections:	FlowCon A: Fixed female ISO or NPT FlowCon AB: Fixed female ISO or NPT FlowCon ABV: Union end connection in brass alloy ISO or NPT
Capillary tube:	$\varnothing$ 3mm, length: 1.0 meter copper

## DIMENSIONS AND WEIGHTS (NOMINAL) (measured in mm unless noted)

Valve model	Valve size	Insert size	L	H1	H2	End connections C <sup>1</sup>			Weight <sup>2</sup> (kgs.) w/o end conn.	Kv <sup>3</sup> (m <sup>3</sup> /hr)
						ISO female	ISO male	Sweat		
A	15	20	80	31	50	-	-	-	0.58	3.1
	20					-	-	-	0.53	
	25					-	-	-	0.56	
AB	15	20	82	31	66	-	-	-	0.51	3.1
	20					-	-	-	0.56	
	25					-	-	-	0.62	
ABV1	15	20	122	33	66	22	24	20	0.85	3.1
	20					22	25	20		
	25					-	39	22		

Note 1: Add end connection length to body length.

Note 2: Weight does not include SDP-insert (0.119 kgs) or capillary-tube with connection to QuickDisc partner valve (0.0535 kgs).

Note 3: For valve body.

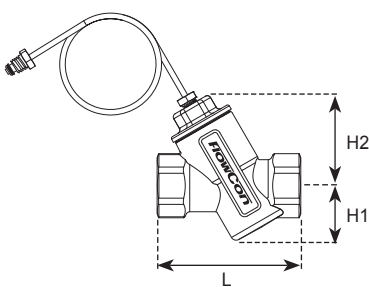

*FlowCon SDP  
with FlowCon A valve*

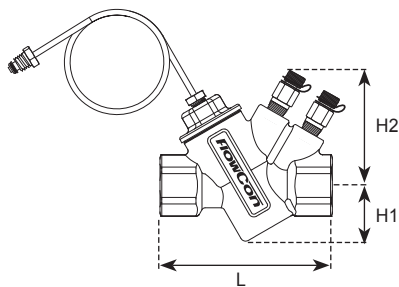

*FlowCon SDP  
with FlowCon AB valve*

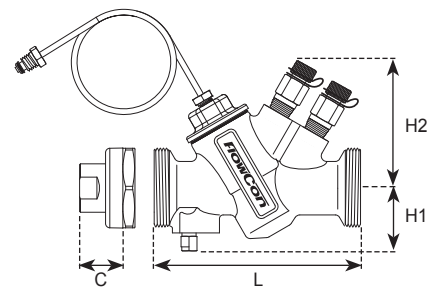

*FlowCon SDP  
with FlowCon ABV1 valve*

## MODEL NUMBER SELECTION

**SDP** . . . . .

Insert insert type:  
**10**=10 kPa   **20**=20 kPa   **30**=30 kPa

Insert type of body:  
**01**=AB15   **02**=AB20   **03**=ABV1   **04**=A15   **05**=A20   **06**=A25   **07**=AB25  
**51**=AB15.DZR   **52**=AB20.DZR

Insert p/t plug requirements:  
**B**=pressure/temperature plugs   **P**=taps plugged   - leave blank if A- or AB-body or no p/t plugs required

Insert inlet x outlet union end connections:   - leave blank if A- or AB-body or no end connections required

Body model and size	Female threaded	Male treaded	Sweat
SDP.X0.03.XX 15-25mm, 1/2"-1"	<b>E</b> = 15mm=1/2" <b>F</b> = 20mm=3/4"	<b>H</b> = 15mm=1/2" <b>I</b> = 20mm=3/4" <b>J</b> = 25mm=1"	<b>K</b> = 15mm <b>L</b> = 18mm <b>M</b> = 22mm

Capillary tube connection - defined by partner valve connection sizes:  
**1**=Capillary tube for connection to QuickDisc partner valve  
**2**=Capillary tube with union M8 to 1/4" adaptor according to ISO 7.1 (compatible with FlowCon p/t port drillings)

Connections standard:  
**I**=ISO   **N**=NPT (NPT: not available on body type: A25 and AB25)

Example: SDP.10.03.B.EE.1.1=FlowCon SDP (10 kPaD) in FlowCon ABV1 body with p/t plugs and 15mm ISO female union end connections and with capillary tube for connection to QuickDisc partner valve.

## GENERAL DESCRIPTION

The FlowCon SDP serie is differential pressure control valves. The purpose of the valve is to keep a constant differential pressure and thereby avoiding noise from the sub system, which the valve is controlling. Furthermore, the FlowCon SDP can be used as a shut off valve with FlowCon ABV housing.

The FlowCon SDP comes in three versions, each version has a fixed differential pressure limitation stretching from 10, 20 and 30 kPa, so no need of any additional adjustment, when the valve is installed at site.

The main purpose of the FlowCon SDP is to be as basic as possible, resulting in low costs and easy installation without the possibility of adjustment. This can be beneficial in many cases where fast and tamper proofs solutions are preferred.

Flow range (l/hr)					
		Setting:	10	20	30
DN15	Qmin		35	50	50
DN20					
DN25	Qmax		864	960	1419

## FLOW RATE TABLE

$\Delta p_C$ (kPaD)	Flow (l/hr)		
	FlowCon SDP model		
	10 kPaD	20 kPaD	30 kPaD
1			
2			
3	864		
4	773		
5	682		
6	591		
7	500		
8	409		
9	318		
10	227	960	
11	136	880	1419
12	45	800	1355
13		720	1290
14		640	1226
15		560	1161
16		480	1097
17		400	1032
18		320	968
19		240	903
20		160	839
21		80	774
22			710
23			645
24			581
25			516
26			452
27			387
28			323
29			258
30			194
31			129
32			65

The model of FlowCon SDP is engraved at the top of the valve

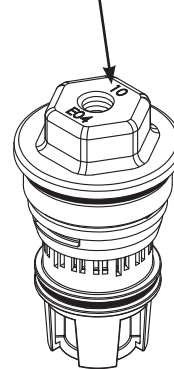

FlowCon SDP  
10 kPaD

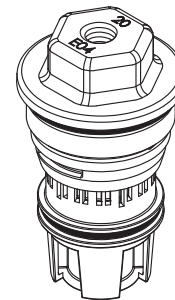

FlowCon SDP  
20 kPaD

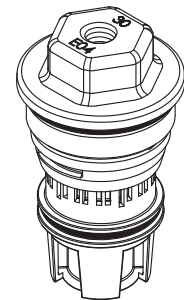

FlowCon SDP  
30 kPaD

## SIZING - HOW TO SELECT

The FlowCon SDP valve is to be selected based on the required flow rates and the calculated differential pressure across the controlled circuit ( $\Delta p_C$ ) at design flow (see flow rate table - previous page - and the flow rate curves below for reference).

The installed FlowCon SDP will hereafter ensure that the differential pressure across the controlled circuit ( $\Delta p_C$ ) is never superseding the valve rated kPaD (10, 20 or 30 kPaD + tolerances) even at partial load conditions down to the minimum flow values listed.

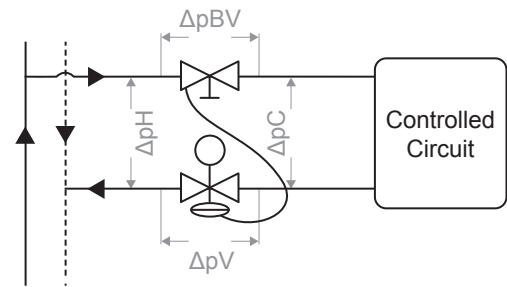

### Example;

Design flow rate = 800 l/hr,

Pipe Size = DN20

$\Delta p_C = 11$  kPaD (design condition)

- Select the valve model** required. The  $\Delta p_C$  and  $\Delta p_{V_{MIN}}$  required by the respective valves at 800 l/hr are shown in the table beside and the flow rate curves below.

	$\Delta p_C$ (kPaD)	$\Delta p_{V_{MIN}}$ (kPaD)
FlowCon SDP 10	3.7	6.5
FlowCon SDP 20	12.0	6.5
FlowCon SDP 30	20.6	8.0

In order to optimize the system energy efficiency are the valve with closest larger value selected; in this case the SDP20. The SDP 20 will allow 880 l/hr of flow at the respective  $\Delta p_C$  and will thereby be capable of supplying the required flow rates. Note that the maximum flow values are to be limited either on the partner valve  $\Delta p_{BV}$  or on the radiator thermostats.

- Valve size is selected** in accordance with the pipe size. If the valves are connected to a DN20 pipe is a 20mm housing selected to eliminate pipe modifications.
- Select the pressure drop across the partner valve ( $\Delta p_{BV}$ )**. In this example a FlowCon QuickDisk is used as partner valve holding a 3 kPaD differential pressure drop @ 800 l/hr in DN20.

- The minimum pump head are now defined:**

$$\Delta p_H = \Delta p_{BV} + \Delta p_C + \Delta p_V \Rightarrow 3 + 11 + 6.5 = 20.5 \text{ kPaD}$$

The SDP 20 will now ensure that the  $\Delta p_C$  never supersedes 22 kPaD as per the flow rate table within the specified flow range.

## FLOW RATE CURVES

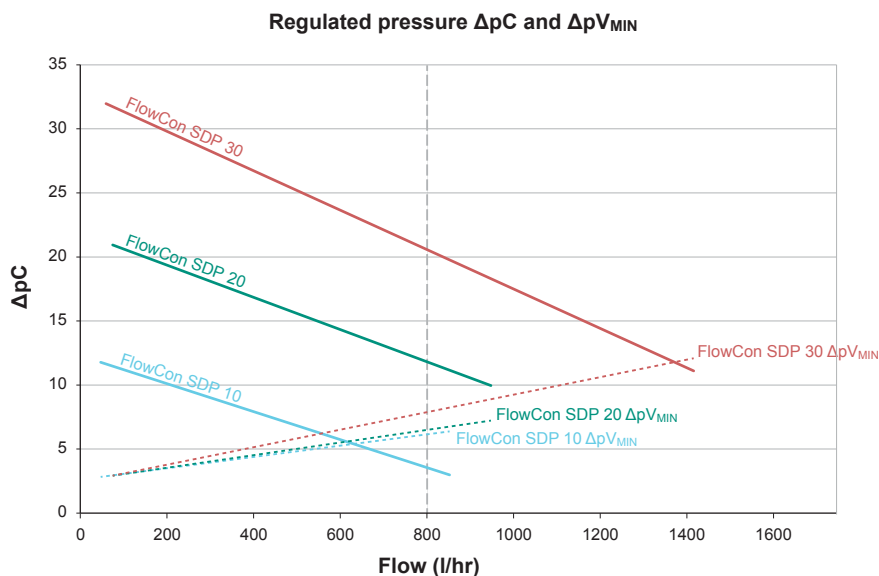

## ACCESSORIES

- Spare part: ACC00120: Capillary tube with fittings for connection to QuickDisc partner valve.
- Spare part: ACC00121: Union M8 to 1/4" adaptor according to ISO 7.1 - compatible with FlowCon p/t port drillings.

## GENERAL SPECIFICATIONS

### 1. DIFFERENTIAL PRESSURE CONTROL VALVES – FLOWCON SDP

- 1.1. Contractor shall install the differential pressure control valves where indicated in drawings.
- 1.2. Valve shall be an insert based, mechanically operated, differential pressure control device, which shall accurately control differential pressure over a sub system independent of system fluctuation.
- 1.3. Valve housing shall consist of bronze CuSn5Zn5Pb2 / CuSn5Zn5Pb5-C, rated at no less than 2500 kPa static pressure and +120°C.
- 1.4. Valve housing shall be permanently marked to show direction of flow.

### 2. VALVE HOUSING

#### 2.a. FlowCon A

- 2.a.1. Valve housing shall consist of forged brass ASTM CuZn40Pb2, rated at no less than 2500 kPa static pressure at +120°C.

OR....

#### 2.b. FlowCon AB

- 2.b.1. Valve housing shall consist of forged brass ASTM CuZn40Pb2, rated at no less than 2500 kPa static pressure at +120°C.
- 2.b.2. Pressure/temperature test plugs for verifying accuracy of flow performance shall be available for all valve sizes.

OR....

#### 2.c. FlowCon ABV

- 2.c.1. Valve housing shall consist of forged brass ASTM CuZn40Pb2, rated at no less than 2500 kPa static pressure at +120°C.
- 2.c.2. Valve ball shall consist of chemically nickel plated brass (ASTM CuZn40Pb2).
- 2.c.3. Pressure/temperature test plugs for verifying accuracy of flow performance shall be available for all valve sizes.

### 3. FLOW AND PRESSURE REGULATION UNIT

- 3.1. Regulation unit shall consist of glass-reinforced PSU/POM/PPS with an EPDM diaphragm.
- 3.2. Regulation unit shall be insert based, for change-out or maintenance without removing the valve from the piping.
- 3.3. Differential pressure shall be tamper proof without possibility for adjustment and available in minimum 3 pressure ranges with 10 kPaD steps for each size.
- 3.4. Regulation unit shall be capable of controlling the differential pressure across the controlled circuit between 3 to 30 kPaD and within a flow rate between 35 to 1419 l/hr.
- 3.5. Valve shall be capable of maintaining specified maximum flow rates within a differential pressure range of 16-400 kPaD.
- 3.6. Upper limit of pressure controller should be no more than 25% higher than the specified DP value at minimum flow.

## APPLICATION AND SCHEMATIC EXAMPLE

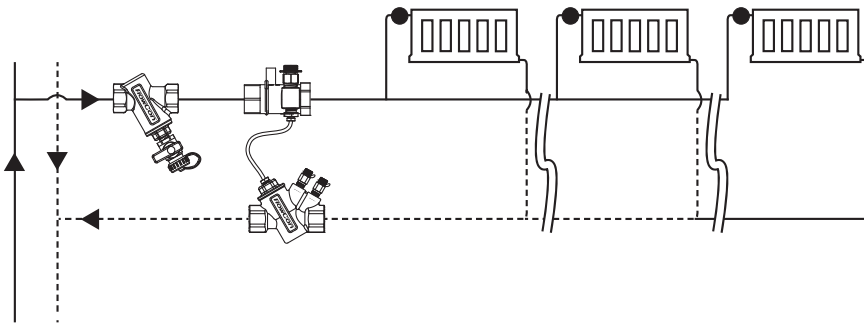

FlowCon SDP mounted on the branch in 2-pipe heating system.

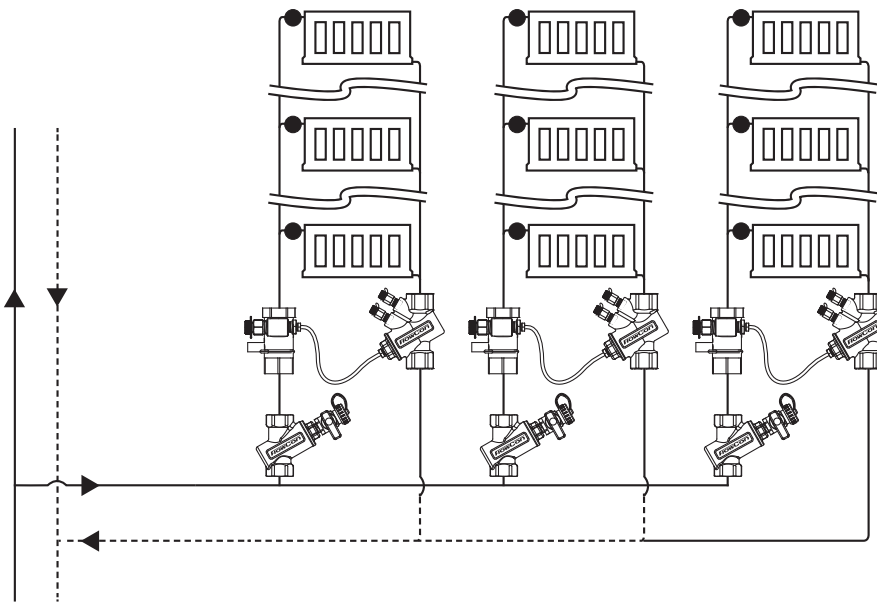

FlowCon SDP mounted on the riser in 2-pipe heating system.

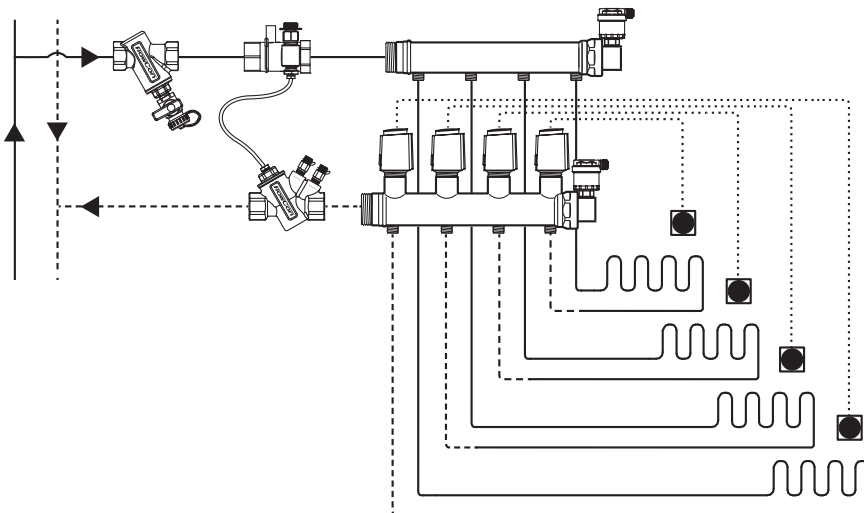

FlowCon SDP mounted on a manifold for underfloor heating system.

## UPDATES

For latest updates please see [www.flowcon.com](http://www.flowcon.com)

FlowCon International can accept no responsibility for possible errors in any printed material. All rights reserved.

# FlowCon DPCV



*Differential Pressure Control Valves*

# FlowCon DPCV

## Differential Pressure Control Valves

The FlowCon DPCV is designed for controlling differential pressure in water based heating and air-conditioning systems, ensuring constant pressure drop over two specific points of the water system regardless of pressure and flow fluctuations.

The FlowCon DPCV will allow the user to set the valve to a pre-defined differential pressure value. To make the installation as easy as possible the setting is done by hand without any usage of tools. To make installation even easier, no special measuring equipment or conversion tables are required during adjustment, since the settings are printed directly on the handle. Once the installation process is completed, the valve allows a tamper-proof function, when the supplied lock ring is fastened with a cable binder. Further, the FlowCon DPCV can be used as a shut-off valve for maintenance purpose.

In heating systems the FlowCon DPCV is primarily intended to be used on the risers or branches with the aim of maintaining a constant differential pressure between the supply and return side. Consequently, for the sub system controlled by the FlowCon DPCV, water velocity through the radiator valves is reduced and potential noise at part loads is minimized.

In cooling systems the FlowCon DPCV is installed in order to absorb any pressure fluctuations introduced by system load changes and potentially VFD pumps, if installed. The absorption of pressure will lead to reduced flow fluctuations and thereby improved balancing and improved energy consumption of the building.

### Features and Benefits

- **Rugged, robust design in bronze/brass.**
- **All functions located on one side** for easier access and use.
- **High flow rates.**
- **Wide pre-setting range** with stepless  $\Delta P$ -scale and without any need of tools.
- **Lockable pre-setting.**
- **Capillary tube** with  $\frac{1}{4}$ " male ISO thread connection, fitting many valve types (including all FlowCon AB/ABV/ABM housings).
- **Available with up to 3 pressure/temperature plugs** for maximum measurement options - possibility of measuring the pressure at:
  - the capillary tube
  - the inlet of the DPCV
  - the outlet of the DPCV.
- Can be used as a **shut-off valve** during maintenance.



### Principle of Operation

The FlowCon DPCV controls the differential pressure between the capillary tube and the inlet of the DPCV. The FlowCon DPCV regulates the differential pressure by means of a diaphragm element counteracted by a spring. The diaphragm element is connected to a cone, which movements change the size of the orifice until the controlled differential pressure is reached. When pre-setting the differential pressure, the spring is tightened or loosened so that the balance will be found at a higher or lower differential pressure than before. When the valve is used as a shut-off valve, the cone closes off the orifice.

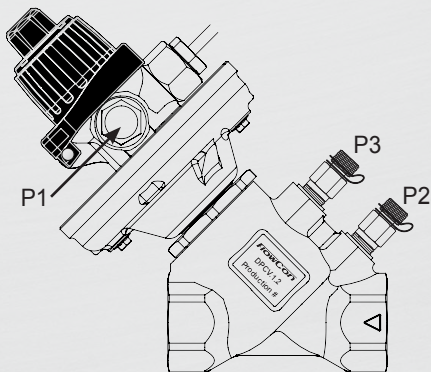

### Pressure Verification

Optional pressure/temperature test plugs are available for verifying the differential pressure. They are fitted into 1/4" ISO female threaded ports. With the pressure/temperature plugs fitted, a pressure differential reading across the FlowCon DPCV can be taken (P2÷P3). Using a combination of other pressure/temperature plugs the controlled pressure differential across the riser or branch can be read (P1÷P2).

### Differential Pressure Setting

For adjusting the differential pressure range of the FlowCon DPCV simply lift the lock-ring and turn the handle to the required setting without using additional tools. Settings can be read directly on the scale on the handle. As an example, a setting 10 corresponds to a  $\Delta P$  of 10 kPaD (1.5 psid) equal for all FlowCon DPCV valve sizes (DN15-50). But each valve provides a wide stepless setting range between 5 and 35 kPaD (0.7-5.1 psid).

After setting  $\Delta P$  the lock-ring is re-fitted and can optionally be locked with a cable binder securing the valve to be tamper-proof.

### Shut-off Function

The built-in shut-off function is activated by turning with an Allen key counter-clockwise at top of the FlowCon DPCV handle until the end point. Opening the FlowCon DPCV again is done with a clockwise movement with the Allen key until end point. The  $\Delta P$  setting is kept as per memory stop.

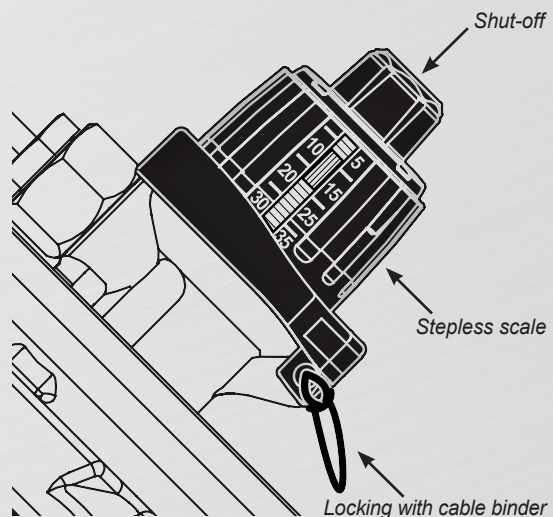

## Technical Data

For further information please see FlowCon tech notes. For latest updates please see [www.flowcon.com](http://www.flowcon.com).

Valve size		DPCV DN15	DPCV DN20	DPCV DN25	DPCV DN32	DPCV DN40	DPCV DN50
Static Pressure	(kPa)	1600					
	(psi)	232					
Temperature Rating (media)	(°C)	+130					
	(°F)	+266					
Pressure Drop Data		NOTE: For pump head calculations, add the minimum pressure differential for the index circuit to the other components pressure losses (i.e. valves, coil, etc.)					
Valve	Kv-value (m <sup>3</sup> /hr)	3.6	5.8	7.1	15.4	22.0	35.8
	Cv-value (GPM)	4.2	6.7	8.2	17.9	25.5	41.5
Differential pressure range	(kPaD)	5-35					
	(psid)	0.7-5.1					
Flow Rate	(l/hr)	50-1700	70-2600	110-3000	150-6500	200-9000	500-13000
	(GPM)	0.22-7.48	0.31-11.5	0.48-13.2	0.66-28.6	0.88-39.6	2.20-57.2



A Griswold Controls LLC./FlowCon International Company

[www.flowcon.com](http://www.flowcon.com)

D E N M A R K · D U B A I · U S A · S I N G A P O R E

## FlowCon DPCV 15-50mm

*Differential Pressure Control Valve*

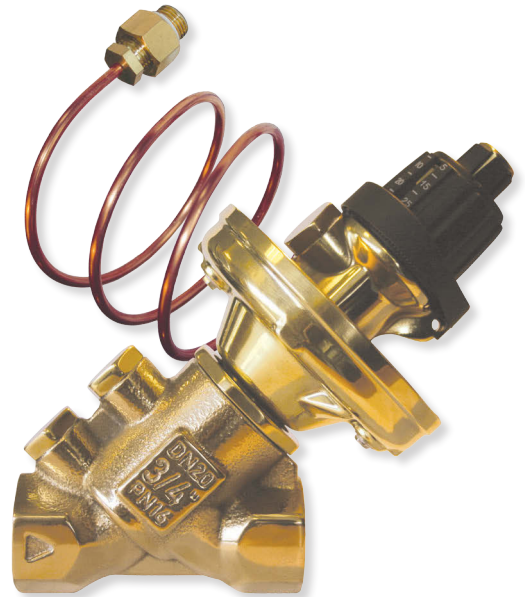

### SPECIFICATIONS

Static pressure:	1600 kPa / 232 psi
Temperature rating, media:	-20°C to +130°C / -4°F to +266°F
Material:	
- Body:	Bronze CuSn5Zn5Pb2 / CuSn5Zn5Pb5-C and Brass CuZn39Pb3
- Internal parts:	Brass CuZn39Pb3 / Stainless steel
- O-rings:	EPDM
- Seat:	EPDM
- Diaphragm:	EPDM
- Capillary tube:	Cu
- Spring:	Stainless steel
- Plastic parts:	PA
- Fasteners:	Stainless steel / Carbon steel nickel plated
Maximum operational $\Delta P$ :	210 kPaD / 30 psid
Differential pressure range:	5 kPaD to 35 kPaD / 0.7 psid to 5.1 psid
End connections:	Fixed female ISO (ISO7, DIN2999)
Capillary tube:	Ø4mm, length: 0.8m, end connection: 1/4" ISO thread

## DIMENSIONS AND WEIGHTS (NOMINAL) (measured in mm unless noted)

Model no.	Valve size	L1	L2	H1	H2	W	Weight (kgs.)	Kvs
DPCV.1.1.X.I	15mm	75	140	28	112	87	1.5	3.6
DPCV.1.2.X.I	20mm	80	140	28	112	87	1.6	5.8
DPCV.1.3.X.I	25mm	90	143	28	115	87	1.8	7.1
DPCV.1.4.X.I	32mm	110	188	35	153	117	3.6	15.4
DPCV.1.5.X.I	40mm	120	194	36	158	117	4.0	22.0
DPCV.1.6.X.I	50mm	150	206	45	161	117	4.9	35.8

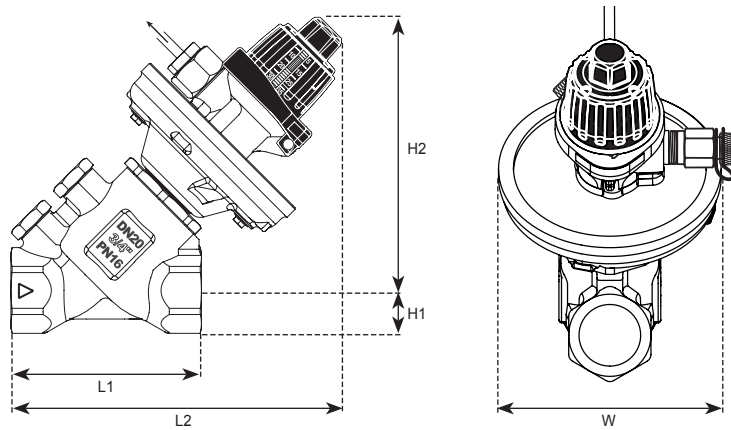

## MODEL NUMBER SELECTION

**DPCV . 1 . . . I**

Insert controlled differential pressure range:  
**1**=5-35 kPaD / 0.7-5.1 psid (standard)

Insert body type:  
**1**=15mm (1/2") **2**=20mm (3/4") **3**=25mm (1") **4**=32mm (1 1/4") **5**=40mm (1 1/2") **6**=50mm (2")

Insert p/t plug requirements:  
**B**=2 pressure/temperature plugs  
**C**=3 pressure/temperature plugs  
**P**=taps plugged (standard)

Insert connections standard:  
**I**=ISO (standard)

Example: DPCV.1.2.C.I=DPCV DN20 with 3 pressure/temperature plugs 20mm ISO female end connections, 5-35kPaD.

Note 1: the extra p/t plug can be used to measure the pressure in the capillary tube.

## GENERAL DESCRIPTION

The FlowCon DPCV series are differential pressure control valves. Each valve has an adjustable differential pressure setting to enable differential pressure limitation for balancing or avoiding noise from the sub system that the valve is controlling. Furthermore, the DPCV can be used as a shut-off valve.

The FlowCon DPCV is easy to adjust without special equipment or conversion tables since the setting is printed directly on the valve which is adjusted by hand. The valve is tamper-proof when the supplied lock ring is fastened with a cable binder.

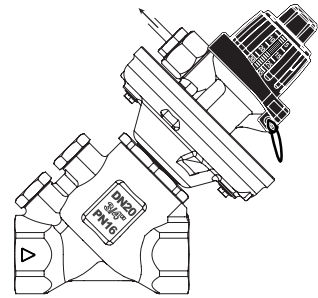

## DIFFERENTIAL PRESSURE LIMITATION SETTINGS

General settings of $\Delta P$ controlled			Operational $\Delta P$			
Setting	kPaD	psid	Min.		Max./Recommended max.	
			kPaD	psid	kPaD	psid
5	5	0.7	25	3.6	210/90	30/13
10	10	1.5	30	4.4	210/110	30/16
15	15	2.2	35	5.1	210/130	30/19
20	20	2.9	40	5.8	210/150	30/22
25	25	3.6	45	6.5	210/170	30/25
30	30	4.4	50	7.3	210/190	30/28
35	35	5.1	55	8.0	210/210	30/30

Accuracy: Greatest of either  $\pm 25\%$  of controlled differential pressure or  $\pm 10\%$  of maximum differential pressure.

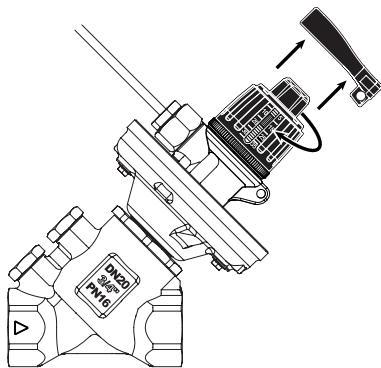

Turn the top wheel by hand until the setting is reached.

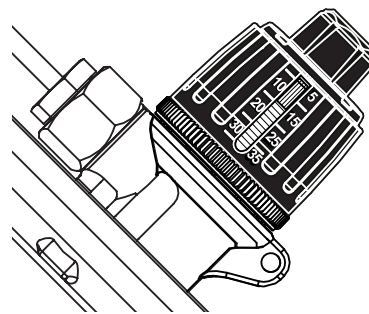

The picture shows a setting of 5 kPa (factory setting).

For a more precise setting or to reach a setting in between the settings in the table, please measure the controlled differential pressure while adjusting the setting.

## MAXIMUM FLOW RATE LIMITATION SETTINGS

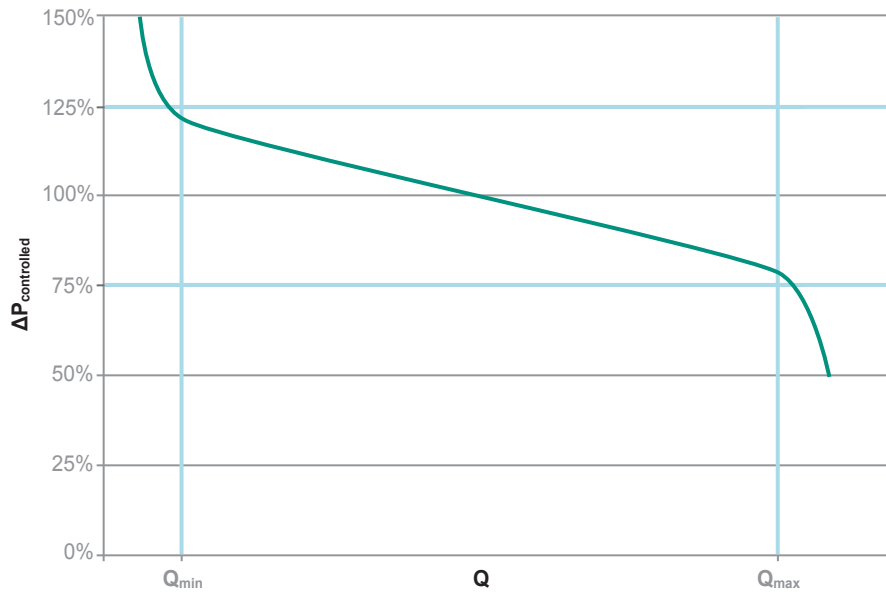

		Flow range (l/h)						
Setting:		5	10	15	20	25	30	35
DN15	Qmin	50	60	70	80	90	105	120
	Qmax	1600	1600	1600	1600	1600	1650	1700
DN20	Qmin	70	80	90	105	120	135	150
	Qmax	2100	2150	2400	2450	2500	2550	2600
DN25	Qmin	110	120	130	145	160	185	200
	Qmax	2250	2400	2600	2850	2900	2950	3000
DN32	Qmin	150	150	150	150	150	150	150
	Qmax	3600	4200	4600	5000	5500	6000	6500
DN40	Qmin	200	200	200	200	200	200	200
	Qmax	6000	6600	7200	7900	8200	8600	9000
DN50	Qmin	500	500	500	500	500	500	500
	Qmax	6300	8000	10000	12000	12300	12600	13000

## ACCESSORIES

- Capillary tube with fittings, spare part: ACC00120.

## GENERAL SPECIFICATIONS

### 1. DIFFERENTIAL PRESSURE CONTROL VALVES

- 1.1. Contractor shall install the differential pressure control valves where indicated in drawings.
- 1.2. Valve shall be a differential pressure control device. Differential pressure control valve shall accurately control differential pressure over a sub system independent of system fluctuation.
- 1.3. Differential pressure shall be available in 1 range for DN15 to DN50. The differential pressure setting shall be continuously adjustable within the range 5-35 kPaD. Valve shall be externally adjustable while in-line and the system in operation.
- 1.4. The differential pressure control valve shall be capable of controlling the differential pressure within  $\pm 25\%$  of controlled differential pressure or  $\pm 10\%$  of the maximum setting.
- 1.5. Valve shall be able to function as a shut-off valve meanwhile it will not functioning as a differential pressure control valve.
- 1.6. Valve housing shall consist of bronze CuSn5Zn5Pb2 / CuSn5Zn5Pb5-C, rated at no less than 1600 kPa static pressure and  $+130^{\circ}\text{C}$ .
- 1.7. Valve housing shall be permanently marked to show direction of flow.
- 1.8. Differential pressure regulation parts shall consist of brass, copper and stainless steel with EPDM diaphragm and sealing parts.
- 1.9. Optional pressure/temperature test plugs for verifying accuracy of differential pressure performance shall be available for all valve sizes.

## APPLICATION AND SCHEMATIC EXAMPLE

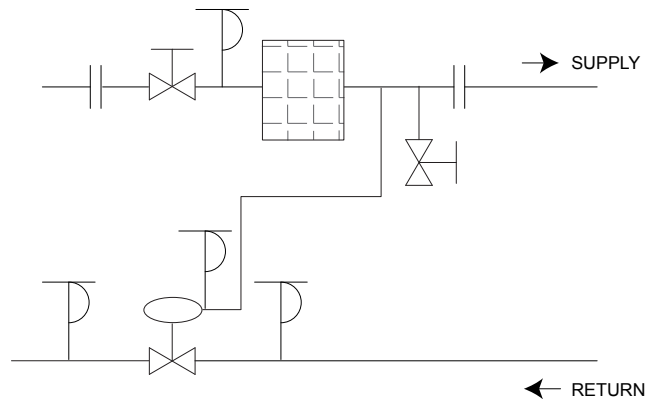
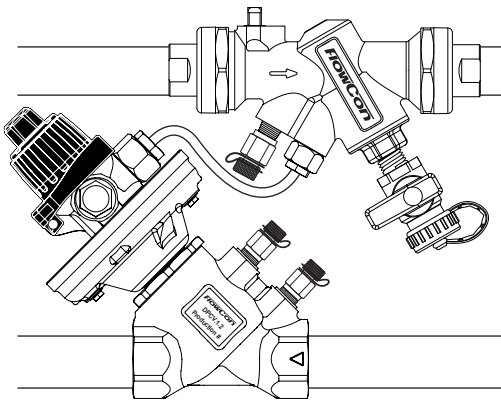

## UPDATES

For latest updates please see [www.flowcon.com](http://www.flowcon.com)

FlowCon International can accept no responsibility for possible errors in any printed material.  
All rights reserved.

# FlowCon ADP 15-25mm

*Combined  $\Delta p$  Controller, Balancing and Control Valve*

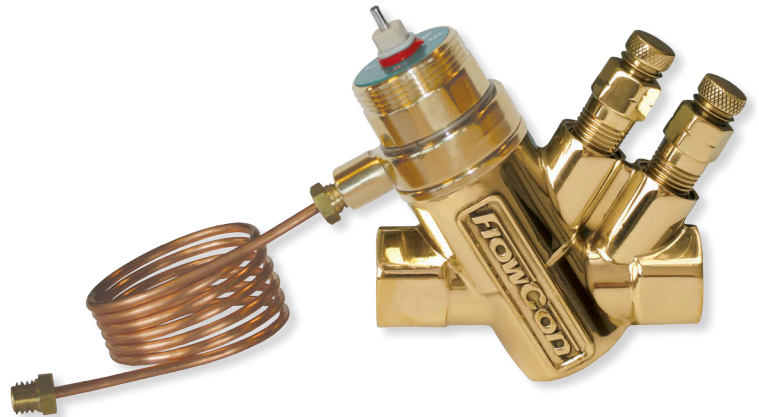

## SPECIFICATIONS

### **ADP:**

Static pressure:	2500 kPa / 360 psi
Media temperature:	-20°C to +120°C / -4°F to +248°F
Material:	
- Insert:	Glass-reinforced PSU/POM/PPS
- Diaphragm:	EPDM
- Internal metal components:	Stainless steel
- O-rings:	EPDM
- Cone:	PPS
Maximum close off pressure:	600 kPaD / 87 psid
Maximum operational $\Delta P$ :	400 kPaD / 58 psid
Shut-off leakage:	ANSI / FCI 70-2 2006 / IEC 60534-4 - Class IV
Flow rate range:	9-680 l/hr / 0.040-2.994 GPM

### **Valve:**

Material:	
- Body:	Forged brass ASTM CuZn40Pb2 / DZR CuZn36pb2As
- Ball valve:	ABV: Chemically nickel plated brass ball
End connections:	A: Fixed female ISO or NPT AB: Fixed female ISO or NPT ABV: Union end connection in brass alloy ISO or NPT
Capillary tube:	$\varnothing$ 3mm, length: 1.0m copper.

## SPECIFICATIONS (...continued)

### FlowCon Actuators available for FlowCon ADP

FlowCon Actuator <sup>1</sup>	FT.0.3	FT.0.4
Supply voltage	230V AC ±10%, 50/60Hz	24V AC/DC -10%... +20%, 50/60Hz
Type	Thermal	Thermal
Power consumption	1.2W	1.2W
Control signal	ON/OFF, Normally closed	ON/OFF, Normally closed
Failsafe function	Yes	Yes
Operation time <sup>2</sup>	App. 4.5 minutes	App. 4.5 minutes
Ambient temperature <sup>3</sup>	+1°C to +50°C	+1°C to +50°C
Protection	IP54 including upside-down, class II	IP54 including upside-down, class III
Cable	Fixed, 1 meter	Fixed, 1 meter
Weight	0.11 kg	0.11 kg

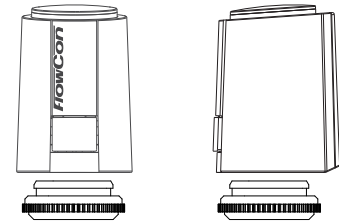

FlowCon FT.0.3/0.4

Note 1: FlowCon warranty is voided using other actuators than supplied by FlowCon International.

Note 2: Closing time is approximately the double dependent on ambient temperature.

Note 3: Stated temperature rating is defined due to no external insert condensation.

## DIMENSIONS AND WEIGHTS (NOMINAL) (measured in mm unless noted)

Model no.	Valve model	Valve size	Insert size	L	H	H1	H2 w/cap	H3 FT.0.3/0.4 act.	End connections C <sup>4</sup>			Weight <sup>5</sup> (kgs.)	Kv <sup>6</sup> (m <sup>3</sup> /hr)	
									ISO female	ISO male	Sweat			
ADP.04	A	15	20	80	31	72	78	125	n/a	n/a	n/a	0.58	2.6	
ADP.05		20												0.53
ADP.06		25												0.56
ADP.01	AB	15	20	82	31	72	78	125	n/a	n/a	n/a	0.51	2.6	
ADP.02		94		0.56										
ADP.07		102		0.62										
ADP.03	ABV1	15	20	122	33	72	78	125	22	24	20	0.85	2.6	
		22							25	20				
		n/a							39	22				

Note 4: Add end connection length to body length.

Note 5: Weight does not include end connections, insert, capillary tube or actuator (the weight of the insert and capillary tube is 0.28 kgs.).

Note 6: For valve body only.

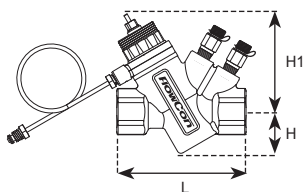

FlowCon ADP 20mm with FlowCon AB DN15-20-25

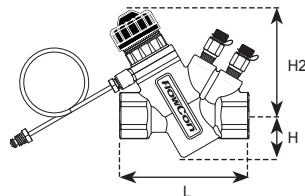

FlowCon ADP 20mm with FlowCon AB DN15-20-25 and with FlowCon Protection Cap

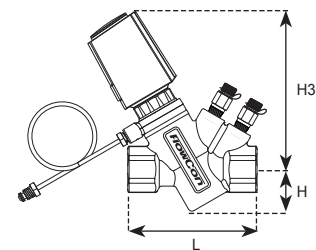

FlowCon ADP 20mm with FlowCon AB DN15-20-25 and with FlowCon FT actuator

## MODEL NUMBER SELECTION

ADP .

Insert type of body:

**01**=AB15 **02**=AB20 **03**=ABV1 **04**=A15 **05**=A20 **06**=A25 **07**=AB25  
**51**=AB15.DZR **52**=AB20.DZR

Insert type of actuator:

**00**=No actuator **23**=FT.0.3 **24**=FT.0.4

Insert p/t plug requirements:

**B**=pressure/temperature plugs **P**=taps plugged - leave blank if A-body or no p/t plugs required

Insert inlet x outlet union end connections: - leave blank if A- or AB-body or no end connections required

Body model and size	Female threaded	Male threaded	Sweat
ADP.03.XX 15-25mm, 1/2"-1"	<b>E</b> = 15mm=1/2" <b>F</b> = 20mm=3/4"	<b>H</b> = 15mm=1/2" <b>I</b> = 20mm=3/4" <b>J</b> = 25mm=1"	<b>K</b> = 15mm <b>L</b> = 18mm <b>M</b> = 22mm

Capillary tube connection - defined by partner valve connection sizes:

**1**=Capillary tube for connection to QuickDisc partner valve

**2**=Capillary tube with union M8 to 1/4" adaptor according to ISO 7.1 (compatible with FlowCon p/t port drillings)

Connections standard:

**I**=ISO **N**=NPT (NPT: not available on body type: A25 and AB25)

Example: ADP.01.00.B.1.=FlowCon ADP in FlowCon AB body (15mm), no actuator, capillary tube for connection to QuickDisc and with p/t plugs and 15mm ISO female union end connections.

## SIZING - HOW TO SELECT

The FlowCon ADP valve is to be selected based on the required flow rates and the calculated differential pressure across the controlled circuit ( $\Delta p_C$ ) at design flow - see flow rate table and flow rate curves for reference.

The installed FlowCon ADP will hereafter ensure that the set design flow are never superseded and that the differential pressure across the controlled circuit ( $\Delta p_C$ ) are never superseding 17 kPaD even at partial load conditions.

The minimum required pump head are specified in the curve: Minimum Pump Head Required (below).

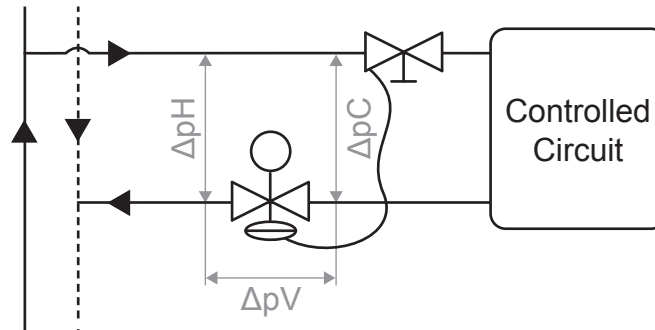

Example;

A flow rate of 340 l/hr is required with a differential pressure drop across the controlled circuit ( $\Delta p_C$ ) being 7 kPaD considering the design flow the following sizing be made;

$\Delta p_H = 15.8$  kPaD (data found in curve below: Minimum pump head required).

Valve setting = 3.0 (see the flow rate table and the flow rate curves next page for reference).

Valve is now set to ensure that a differential pressure of 7 kPaD is maintained at the design flow of 340 l/h. In case partial load may the differential pressure increase over the controlled circuit ( $\Delta p_C$ ), but this will not supersede 17 kPaD.

## MINIMUM PUMP HEAD REQUIRED ( $\Delta p_H$ )

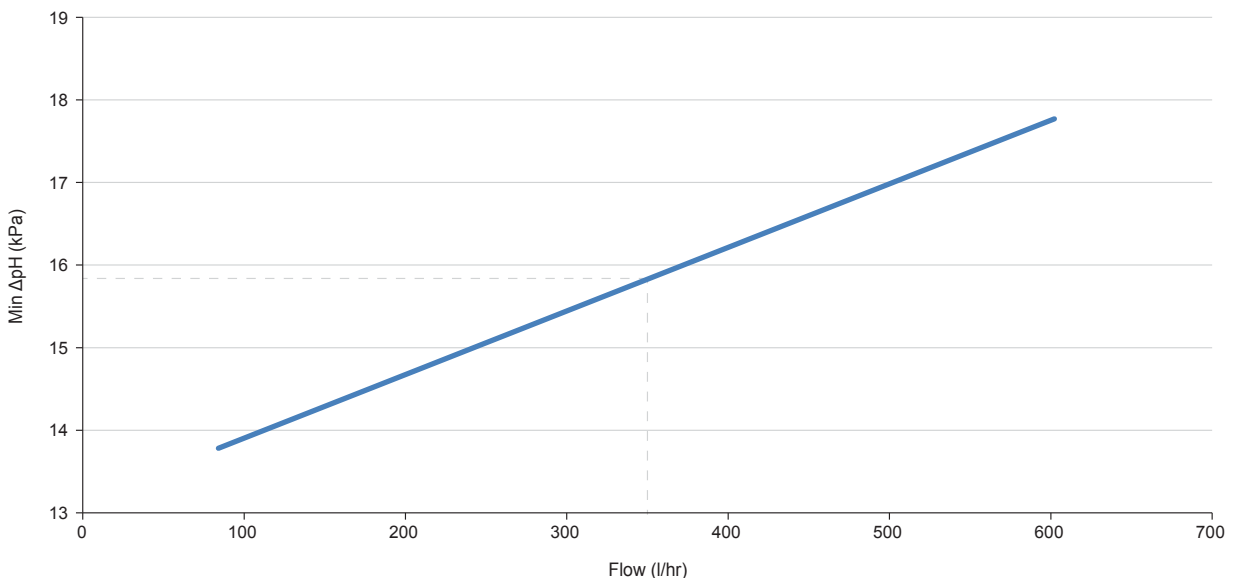

Please consider above minimum pump head required ( $\Delta p_H$ ) upon pump sizing.

## FLOW RATE TABLE

ΔpC (kPa)	Flow (l/hr)														
	FlowCon ADP settings														
	1.0	1.2	1.4	1.6	1.8	2.0	2.2	2.4	2.6	2.8	3.0	3.5	4.0	4.5	5.0
3	84	120	170	230	280	330	370	400	420	450	470	550	610	630	680
4	79	110	160	210	260	310	340	370	390	420	440	510	570	590	630
5	73	100	150	190	240	290	320	340	360	380	410	470	520	540	590
6	67	96	130	180	220	260	290	320	330	350	380	440	480	500	540
7	61	88	120	160	200	240	270	290	310	320	340	400	440	460	490
8	55	79	110	150	190	220	240	260	280	290	310	360	400	410	450
9	50	71	99	130	170	190	220	230	250	260	280	320	360	370	400
10	44	63	88	120	150	170	190	210	220	230	250	280	320	330	350
11	38	54	76	100	130	150	170	180	190	200	210	250	270	280	310
12	32	46	64	86	110	130	140	150	160	170	180	210	230	240	260
13	26	38	53	70	88	100	120	120	130	140	150	170	190	200	210
14	21	30	41	55	69	81	90	97	100	110	120	130	150	150	170
15	15	21	30	39	49	58	65	70	74	78	83	96	110	110	120
16	12	17	24	32	40	47	52	56	59	63	66	77	86	88	96
17	9	13	18	24	30	35	39	42	45	47	50	58	65	67	72



A Micrometer setting of 3.0 as illustrated beside corresponds to a differential pressure in the controlled circuit (ΔpC) of 7 kPaD when the design flow of 340 l/hr is achieved.

Use the key (FlowCon part no. ACC0001) for micrometer setting.

## FLOW RATE CURVES

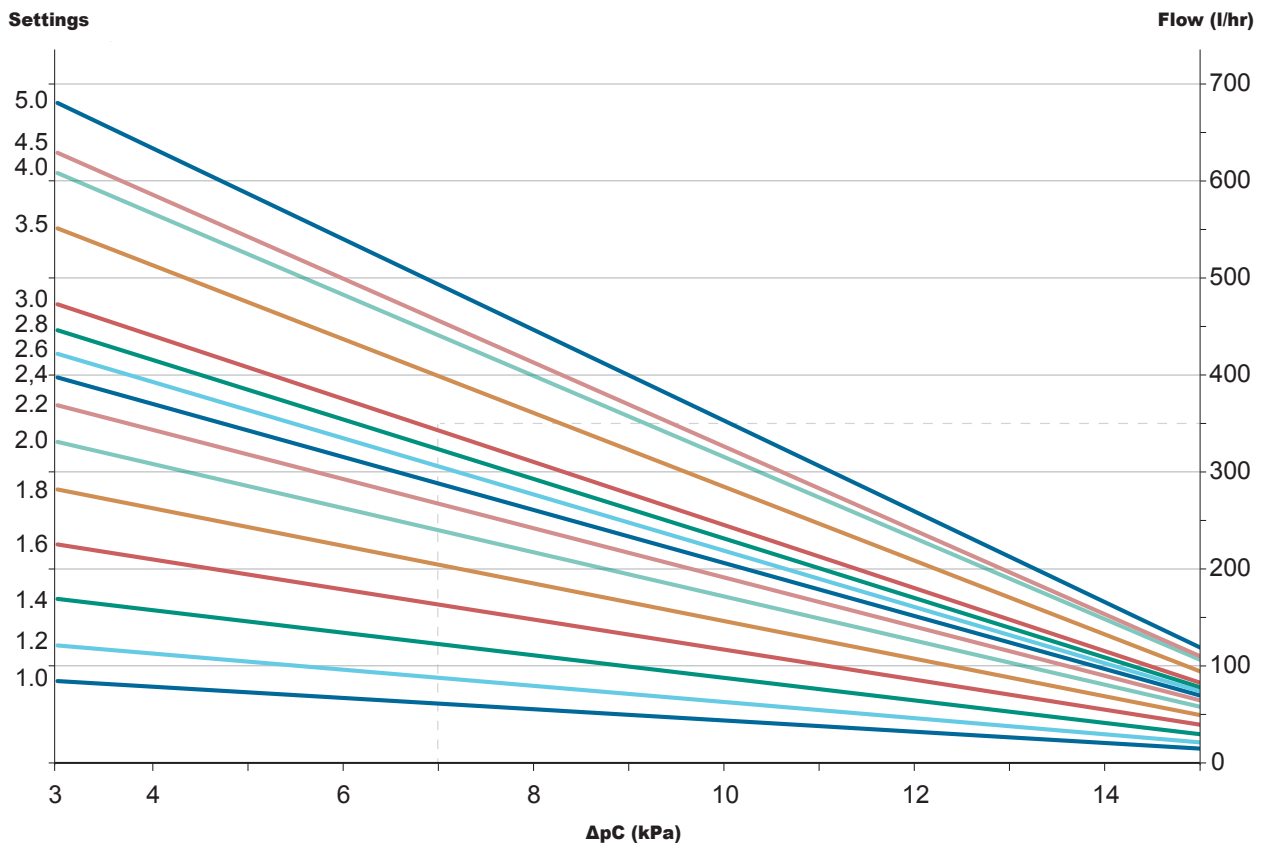

## APPLICATIONS

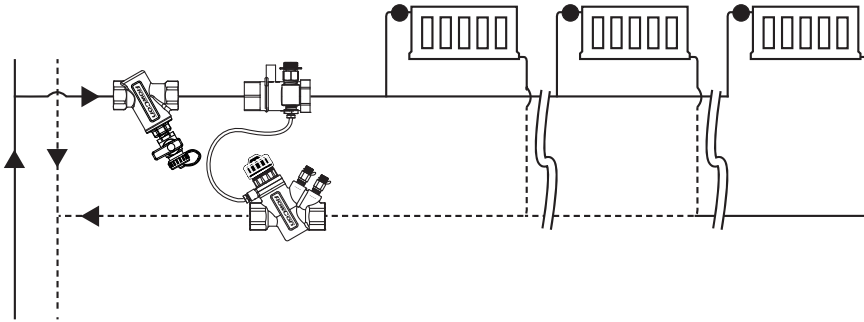

FlowCon ADP mounted on the branch in 2-pipe heating system.

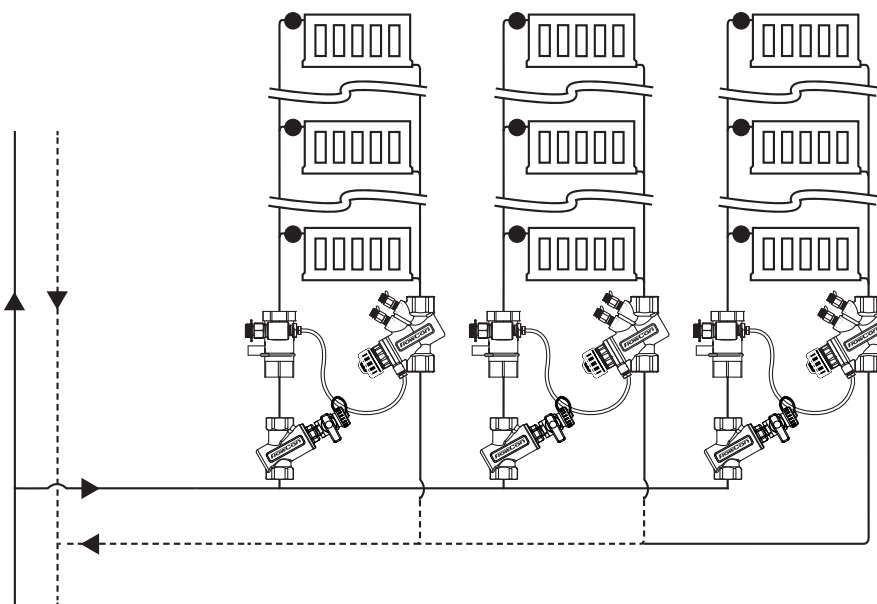

FlowCon ADP mounted on the riser in 2-pipe heating system.

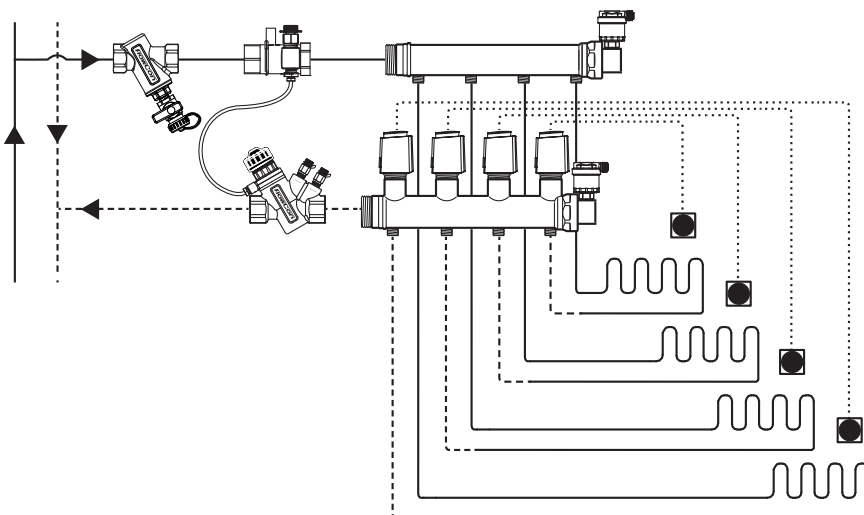

FlowCon ADP mounted on a manifold for underfloor heating system.

## APPLICATIONS (...continued)

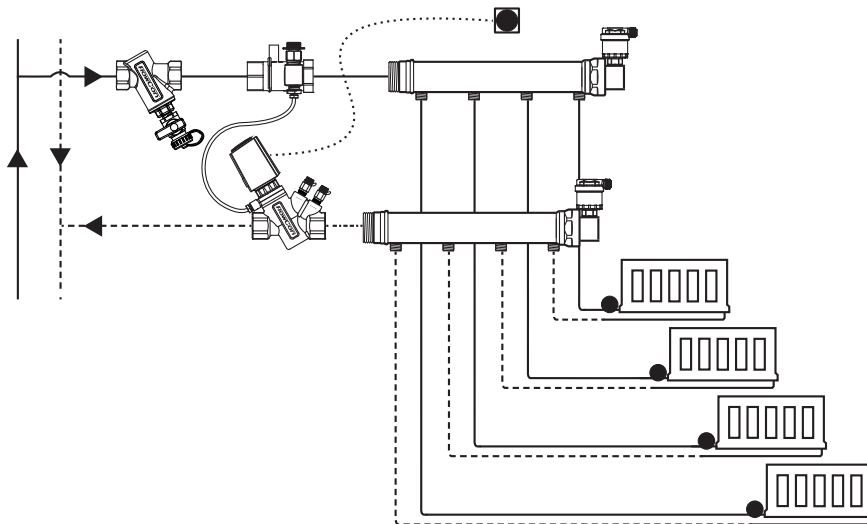

FlowCon ADP used as zone valve for a manifold distribution system.

## DESCRIPTION

The FlowCon ADP series is a combination of a pressure independent control valve as well as a differential pressure controller. The range features the traditional advantageous of a pressure independent control valve (PICV) - pressure independent maximum flow limitation, 100% authority if mounted with actuator - but do simultaneously ensure that the differential pressure across the controlled circuit do not supersede the valve values.

The differential pressure safety feature makes the valve perfect for locations, where a traditional PICV, are not suitable due to noise concerns, such as heating system branches or equivalent.

The ADP will in other words ensure a low stable differential pressure across the controlled circuit and simultaneously ensure that the maximum flow never superseded the design value. The integration of the PICV valve and the differential pressure control valve DPCV ensure full functionality of both valves without any conflict and with a minimal pressure drop.

## GENERAL SPECIFICATIONS

### 1. FLOW LIMITING DIFFERENTIAL PRESSURE CONTROLLER – FLOWCON ADP

- 1.1. Contractor shall install the flow limiting differential pressure controller where indicated in drawings.
- 1.2. Valve shall be a insert based, mechanically operated, differential pressure and flow control device with the option of adding an actuator make it a pressure independent control device.
- 1.3. Flow limiting differential pressure control valve shall accurately control flow and ensure that the differential pressure across the control circuit newer supersedes the valve value, independent of system pressure fluctuation.
- 1.4. Maximum flow setting shall be adjustable to 41 different settings within the range of the valve size.

### 2. VALVE ACTUATOR

- 2.a. FlowCon FT actuators
  - 2.a.1. Valve actuator housing shall be rated to IP54, including up-side-down mounting.
  - 2.a.2. Actuator shall be driven by 24V or 230V AC, and shall accept ON/OFF control signal.
  - 2.a.3. Actuator shall have visible indication of stroke position.
  - 2.a.4. Failsafe function shall be available on all version.

### 3. VALVE HOUSING

- 3.a. FlowCon A
  - 3.a.1. Valve housing shall consist of forged brass ASTM CuZn40Pb2, rated at no less than 2500 kPa static pressure at +120°C.

OR...

- 3.b. FlowCon AB
  - 3.b.1. Valve housing shall consist of forged brass ASTM CuZn40Pb2, rated at no less than 2500 kPa static pressure at +120°C.
  - 3.b.2. Pressure/temperature test plugs for verifying accuracy of flow performance shall be available for all valve sizes.

OR...

- 3.c. FlowCon ABV
  - 3.c.1. Valve housing shall consist of forged brass ASTM CuZn40Pb2, rated at no less than 2500 kPa static pressure at +120°C.
  - 3.c.2. Valve ball shall consist of chemically nickel plated brass (ASTM CuZn40Pb2).
  - 3.c.3. Pressure/temperature test plugs for verifying accuracy of flow performance shall be available for all valve sizes.

### 4. FLOW AND PRESSURE REGULATION UNIT

- 4.1. Regulation unit shall consist of glass-reinforced PSU/POM/PPS with an EPDM diaphragm.
- 4.2. Regulation unit shall be insert based and readily accessible, for change-out or maintenance without removing the valve from the piping. Regulation unit shall be adjustable with the valve in-line and the system in operation.
- 4.3. Regulation unit shall be externally adjustable to 1 of 41 different flow rates without limiting the stroke length.
- 4.4. Regulation unit shall be capable of controlling the differential pressure across the controlled circuit between 3 to 17 kPaD and within a flow rate between 9 to 680 l/h.
- 4.5. Valve shall be capable of maintaining specified maximum flow rates within a differential pressure range of 15-400 kPaD.
- 4.6. Upper limit of pressure controller should be no more than 17 kPaD at minimum specified flow.

## UPDATES

**For latest updates please see [www.flowcon.com](http://www.flowcon.com)**

FlowCon International can accept no responsibility for possible errors in any printed material.  
All rights reserved.

# FlowCon T-JUST



*Thermostatic Valve for Domestic Water*

# FlowCon T-JUST

*Thermostatic Insert for Thermostatic Valves in Domestic Water*



The FlowCon T-JUST is a thermostatic element insert which fits in a standard FlowCon valve body of your choice and is used as a thermostatic control valve designed to control the thermal balance in domestic hot water circulation installations.

The valve automatically controls the temperature of the water which circulates through the system and therefore a thermal balance is achieved throughout the entire system. Further, the proper temperature is immediately available at all draw-off taps to ensure optimal comfort.

The T-JUST insert can be adjusted to the required temperature within a scale of +35°C to +65°C. Also, it is equipped with a manual or actuated by-pass. The purpose of the by-pass is to increase the temperature of the water to maximum temperature for a certain period of time to avoid bacterial problems such as Legionella.

Legionnaire's disease is an infection which in 90% of the cases is caused by Legionella Pheumphila. Since the infection is transmitted when inhaling aerosolized, contaminated water into the lungs, the presence of bacteria in water systems creates a risk wherever there are aerosol-producing devices. The perfect conditions for transmission of infection exist in water tanks and water installations in dwelling buildings, commercial buildings and public buildings such as hotels, hospitals etc.

The normal recommended physical method of bacteria pasteurization is thermal disinfection, where the water is heated up to "disinfection temperature"

and maintained for a specific "disinfection time". FlowCon T-JUST is designed and ready to perform a regular thermal disinfection at a temperature of up to +70°C to lower the risk of Legionella.

## **Features and Benefits**

- **Thermal balancing**, the correct water temperature at each draw-off tap.
- **The thermostatic element and moving parts are located out of water contact**, this will prevent problems with scaling.
- **Field adjustable**, temperature setting can be changed on demand, from +35°C to +65°C.
- **By-passing possibility while the system is working**, either manual or automatic with ON/OFF actuator, normally closed.
- **Accuracy** of  $\pm 2^{\circ}\text{C}$ .
- Each T-JUST is **calibrated separately**.
- Due to design the valve is **not susceptible to blockage**.
- **Product approval**, all valve bodies are available in DZR-brass and T-JUST is approved to meet the requirements in the Danish Building Regulations.
- **Pressure/temperature measurement plugs** available for verifying operating temperature.
- **Double union end connections** for ease of installation and wide selection of end fittings (ABV) or **fixed female threaded ends** (A/AB).

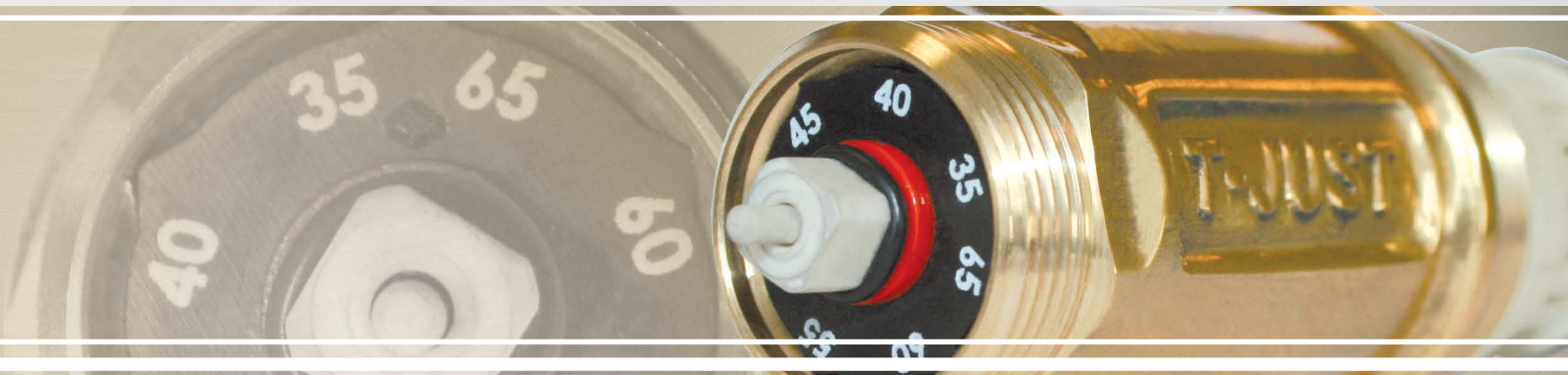

### Applications

The T-JUST insert can be used with the following FlowCon valves:

- FlowCon A (DN15/20/25)
- FlowCon AB (DN15/20/25)
- FlowCon ABV1 (DN15/20/25)
- FlowCon FF-unit (DN20)

The FF-unit is designed to meet market requirements and directly replace other brands of thermostatic valves.

### Principle of Operation

The T-JUST insert controls the temperature of the water which circulates through the system. The valve is in balance, when the water temperature has reached the temperature set on the T-JUST insert. If T-JUST is set to a temperature, of for instance +55°C, and the temperature of the circulating water is above +55°C, the thermostatic element expands and the internal cone moves towards the valve seat and the valve closes. If the temperature is below +55°C, the thermostatic element will contract and the valve will open, allowing more water to flow through.

### Temperature Selection and Setting

To set the temperature simply remove the black cover and set the scale by means of a special FlowCon adjustment key to the desired temperature between +35°C and +65°C. Screw on the top cover tightly to allow the thermostatic control to be working and to avoid unwanted tampering.

Please note that when changing the temperature the according adjustment may take some time to get the system in complete balance again. The T-JUST is factory pre-set to +60°C. Further a minimum  $\Delta T$  of 5°C between the hot-water tank and the temperature set on the T-JUST at the critical tapping point is recommended to allow the expected heat loss in the circulation pipe.

### By-Pass Operation

Manual by-pass operation is carried out simply by removing the black cover and placing the red plastic ring on top of the T-JUST. Placing the black cover above the red by-pass ring and screwing it on tightly will put the thermostatic function out of action and allow maximum water temperature to flow through as long as the top cover is tightened with the red by-pass ring as distance piece.

Alternatively the pasteurization of the water can be carried out automatically by means of a small standard ON/OFF actuator controlled by either the BMS-system or a local timer. Using the BMS-system, duration and maximum temperature of the disinfection process can be programmed to meet customer demands.

The by-pass cannot be regulated since the by-pass function is only necessary during flushing and the thermostatic control during this period of time will be non-existing. Maximum opening means minimum resistance which again means lesser time for flushing.

## Technical Data

For further information and part number selection please see individual FlowCon tech note.

For latest updates please see [www.flowcon.com](http://www.flowcon.com)

		A/AB/ABV DN15/20/25 with T-JUST insert	FF-Unit with T-JUST insert
Static Pressure	(kPa)	1000	1000
	(psi)	145	145
Temperature Rating (media / ambient)	(°C)	0 to +85 / 0 to +60	0 to +85 / 0 to +60
	(°F)	+32 to +185 / +32 to +140	+32 to +185 / +32 to +140
Pressure Drop Data	NOTE: For pump head calculations, add the minimum pressure differential for the index circuit to the other components pressure losses (i.e. valves, coil, etc.)		
Valve with T-JUST	(Kv-value) (m³/hr)	1.1	1.1
	(Cv-value) (GPM)	1.3	1.3

T-JUST Insert		T-JUST
Temperature Range	(°C)	+35 to +65
	(°F)	+95 to +149
Max. Pressure Differential	(kPaD)	100
	(psid)	14.5

## Design Example

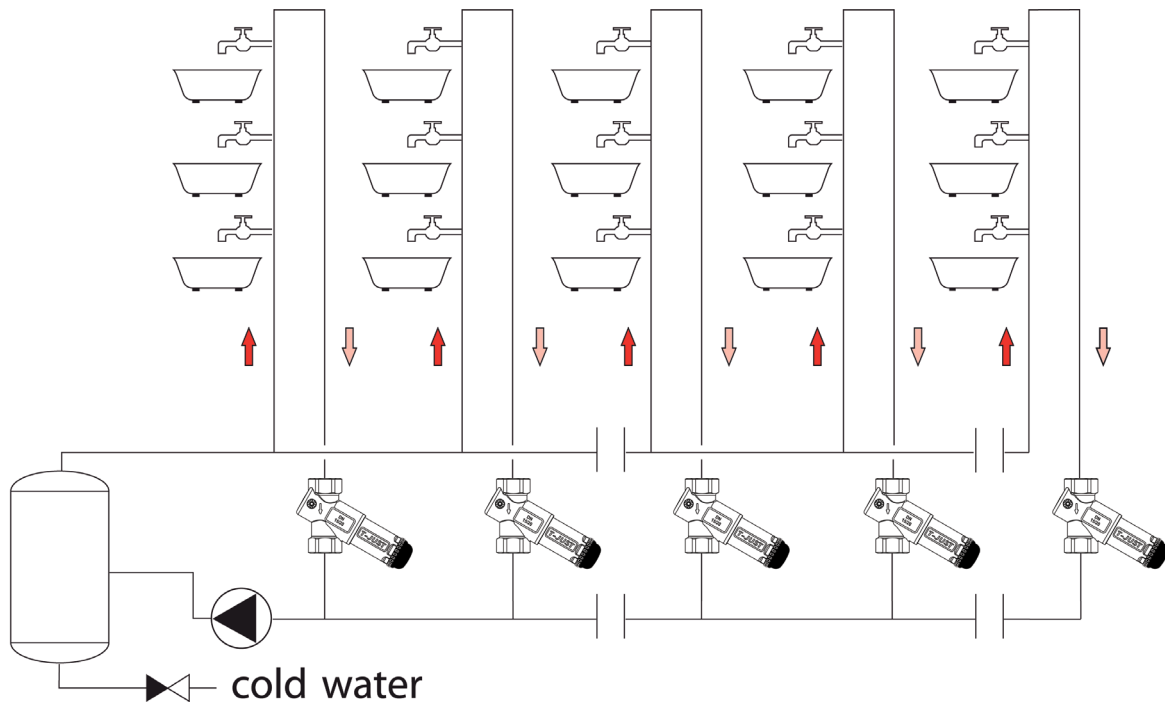

**FlowCon**  
international

A Griswold Controls LLC./FlowCon International Company

[www.flowcon.com](http://www.flowcon.com)

D E N M A R K · D U B A I · U S A · S I N G A P O R E

# FlowCon T-JUST

*Thermostatic Valve for Domestic Water*



## SPECIFICATIONS

### **Insert:**

Pressure rating:	1000 kPa / 145 psi
Temperature rating, media:	0°C to +85°C / +32°F to +185°F
Temperature rating, ambient:	0°C to +60°C / +32°F to +140°F
Material:	
- Insert:	PPS, Polyphenylene sulfide
- Element:	Wax
- Body:	Forged brass ASTM CuZn40Pb2
- Spring:	Stainless steel AISI 302
- Internal components:	PPS, Polyphenylene sulfide
- O-rings:	EPDM
Max. Kv-value:	1.10 m <sup>3</sup> /h
Max. differential pressure:	100 kPaD / 14.5 psid
Temperature range:	+35°C to +65°C / +95°F to +149°F

### **Valve:**

Material:	
- Body:	Forged brass ASTM CuZn40Pb2 or DZR brass CW602N CuZn36Pb2AS
- Ball valve:	ABV: Chemically nickel plated brass ball
End connections:	A: Fixed female ISO AB: Fixed female ISO ABV: Union end conn. in brass alloy ISO FF-unit: Female ISO inlet; male ISO outlet

## SPECIFICATIONS (continued)

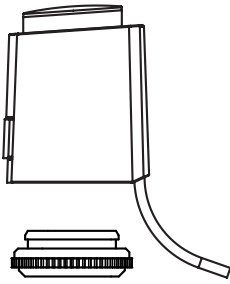

Type EV.0.3.R, EV.0.4.R  
Valve adaptor, red

### Electrical actuator:

#### FlowCon EV.0.3.R<sup>1</sup>, FlowCon EV.0.4.R<sup>1</sup>

Voltage:	EV.0.3.R: 230V AC EV.0.4.R: 24V AC
Control:	ON/OFF, normally closed <sup>2</sup>
Operating power:	1.0 Watt
Closing and opening time:	Approx. 4 min
Ambient temperature:	0°C to +60°C
Protection:	EV.0.3.R: IP54, class II EV.0.4.R: IP54, class III
Cable:	1 meter fixed cable

Note 1: FlowCon warranty is voided using other actuators than supplied or recommended by FlowCon International A/S.  
Note 2: To ensure that the valve is in an open position during commission of the system, the actuator will be delivered in a normal open position and remain in this position until it is electrically operated first time.

## DIMENSIONS AND WEIGHTS (NOMINAL) (measured in mm unless noted)

### FlowCon T-JUST with FlowCon A-body

Valve size	Insert size	L	H1	H2	H3 (with actuator - not shown)	Weight (kgs.)
15	20	80	97	31	130	0.61
20						0.56

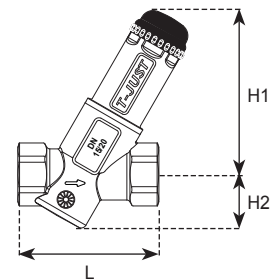

### FlowCon T-JUST with FlowCon AB-body

Valve size	Insert size	L	H1	H2	H3 (with actuator - not shown)	Weight (kgs.)
15	20	82	97	31	130	0.60
20		94				0.64

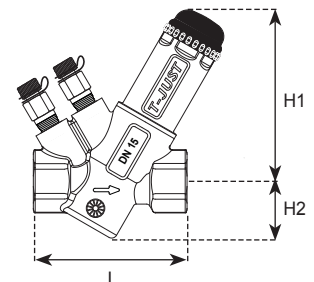

### FlowCon T-JUST with FlowCon ABV1-body

Valve size	Insert size	L	H1	H2	H3 (with actuator - not shown)	End connections C <sup>3</sup>			Weight (kgs.) (w/o end conn.)
						ISO female	ISO male	US Sweat	
15	20	122	97	34	130	22	24	20	1.20
20						22	25	20	
25						-	39	22	

Note 3: Add end connection length to body length.

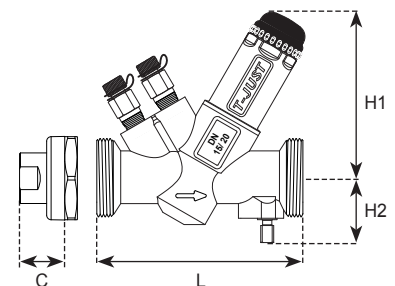

### FlowCon T-JUST with FF-unit<sup>4</sup>

Valve size	Insert size	L	H1	H2	H3 (with actuator - not shown)	Weight (kgs.)
-	20	56	97	32	130	0.59

Note 4: To be fitted as upgrading element.

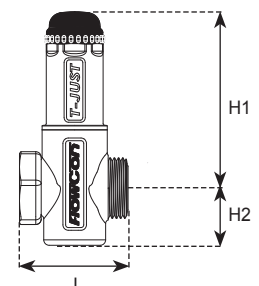

## MODEL NUMBER SELECTION

Insert body size:  
**1**=A-body 15mm  
**2**=A-body 20mm  
**3**=A-body 25mm  
**4**=AB-body 15mm  
**5**=AB-body 20mm  
**6**=AB-body 25mm  
**7**=ABV1-body 15/20/25mm  
**9**=FF-unit 20mm

Insert p/t plug requirements (on AB and ABV-bodies):  
**P**=taps plugged **B**=pressure/temperature plugs **O**=taps open

Insert union end connections (if ABV-body):

Body size	Female threaded	Male treaded	Sweat
Union end 15-25mm with T-JUST insert	<b>E</b> =15mm=1/2" <b>F</b> =20mm=3/4"	<b>H</b> =15mm=1/2" <b>I</b> =20mm=3/4" <b>J</b> =25mm=1"	<b>K</b> =15mm <b>L</b> =18mm <b>M</b> =22mm

Insert connection standard:  
**I**=ISO

Insert valve body material:  
**B**=standard brass **D**=DZR brass **R**=Stainless steel (only A 20mm ISO)

Example: T-JUST4.P.I.B=AB 15mm ISO female threaded standard brass body with plugs and T-JUST insert.

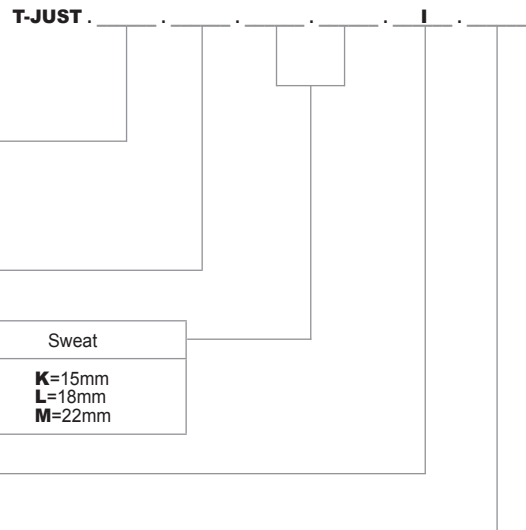

## APPLICATIONS

The FlowCon T-JUST, to be used in either FlowCon A, AB, ABV1 bodies or the FF-unit, is designed for domestic hot water installations with circulation. The FlowCon T-JUST automatically controls the temperature of the water that circulates through the valve and therefore the thermal balance is ensured throughout the domestic hot water system.

The T-JUST will from factory be pre-set to +60°C. Temperature setting is easy – simply remove the black top cover and set the temperature by means of a FlowCon adjustment key. If for instance a water temperature of +55°C is needed, the T-JUST is set to the temperature of +55°C. If the temperature of the circulating water is below +55°C, T-JUST opens and more water will pass through. If the temperature is higher than +55°C, T-JUST closes. The black top cap must be screwed tightly on the T-JUST to activate the thermostatic control (and to avoid tampering).

The by-pass function can be carried out either manually by installing the red by-pass ring (used as indicator) or by means of an on/off actuator. The by-pass will force the T-JUST to fully open and set the temperature control out of action. This function is used to avoid bacterial problems such as Legionella and therefore it is recommended to flush the system regularly, flushing one branch at a time for a recommended period of time. For manual by-pass, adapt the red by-pass ring on the T-JUST and screw the black cap tight for the flushing period. When using automatic by-pass, the actuator can be either timer controlled or controlled by the BMS-system.

For the valve to work efficiently, a certain heat loss must be present, and since the pipes are normally insulated, insulation of the valve is not necessary. Without insulation of the valve, the valve will operate under optimal working conditions and temperature regulation will be more accurate. If insulation is required the valve will still function, but regulation will be less precise.

## ACCESSORIES

- Blind cap: ACC0080 (cap without an insert for flushing out the system)
- Adjustment key: ACC0001
- Manuel by-pass ring: ACC0002 (ring for manual by-pass; 10 pcs. per package)
- Replacement cap, black: ACC0003.

## GENERAL SPECIFICATIONS

### 1. THERMOSTATIC VALVES FOR DOMESTIC WATER - FLOWCON T-JUST

- 1.1. Contractor shall install thermostatic valves where indicated in drawings.
- 1.2. Temperature regulation unit shall be available as a plug-in device for an in-line valve housing and the adjustable element shall be out of contact with the circulating water.

### 2. VALVE ACTUATOR

- 2.1. Actuator shall provide a visual indication of the valve position.
- 2.2. The valve shall be closing when the actuator is not powered.
- 2.3. The valve shall withstand a shut off pressure of at least 400 kPa without allowing internal leakage.
- 2.4. The seat plug shall be manufactured of EPDM rubber.
- 2.5. The packing box for sealing the stem shall be removable with the system in operation, without allowing external leakage.

### 3. VALVE HOUSING

#### 3.a. FlowCon A

- 3.a.1. Valve housing shall consist of forged brass ASTM CuZn40Pb2, rated at no less than 2500 kPa static pressure and +120°C.
- 3.a.2. Valve housing shall be permanently marked to show direction of flow.
- 3.a.3. Housing shall be configured for temperature regulation unit accessibility.

OR....

#### 3.b. FlowCon AB

- 3.b.1. Valve housing shall consist of forged brass ASTM CuZn40Pb2, rated at no less than 2500 kPa static pressure and +120°C.
- 3.b.2. Valve housing shall be permanently marked to show direction of flow.
- 3.b.3. Optional pressure/temperature test plugs for verifying accuracy of flow performance shall be available for all valve sizes.
- 3.b.4. Housing shall be configured for temperature regulation unit accessibility.

OR....

#### 3.c. FlowCon ABV

- 3.c.1. Valve housing shall consist of forged brass ASTM CuZn40Pb2, rated at no less than 2500 kPa static pressure and +120°C.
- 3.c.2. Valve housing shall be permanently marked to show direction of flow.
- 3.c.3. Valve ball shall consist of chemically nickel plated brass (ASTM CuZn40Pb2).
- 3.c.4. Optional pressure/temperature test plugs for verifying accuracy of flow performance shall be available for all valve sizes.
- 3.c.5. Valve housing shall be double union end constructed with a range of pipe connections available for the appropriate pipe size.
- 3.c.6. Housing shall be configured for temperature regulation unit accessibility.

OR...

#### 3.d. FLOWCON FF-UNIT

- 3.d.1. Valve housing shall consist of DZR brass CW602N CuZn36Pb2AS, rated at no less than 2500 kPa static pressure and +120°C.
- 3.d.2. Valve housing shall be permanently marked to show direction of flow.
- 3.d.3. Housing shall be configured for temperature regulation unit accessibility.

### 4. TEMPERATURE REGULATION ASSEMBLY / THERMOSTATIC ELEMENT / T-JUST

- 4.1. Temperature regulation unit shall be manufactured of forged brass ASTM CuZn40Pb2 body, rated at not less than 1000 kPa static pressure and +85°C. Further, the temperature regulation unit shall be manufactured of polyphenylene sulfide insert with stainless steel 18-8 spring and wax element.
- 4.2. Temperature regulation unit shall be readily accessible for change-out or maintenance.
- 4.3. Temperature regulation unit shall be stepless adjustable to a temperature between +35°C and +65°C; and shall be capable of controlling the temperature within  $\pm 2^\circ\text{C}$  of the rated temperature.
- 4.4. Temperature regulation unit shall be ready for either manual by-pass or actuated by-pass without exchanging the unit.

## UPDATES

For latest updates please see [www.flowcon.com](http://www.flowcon.com)

FlowCon International can accept no responsibility for possible errors in any printed material.  
All rights reserved.

# FlowCon Mini By-Pass Unit

## 3 Way Mini By-Pass Unit



### SPECIFICATIONS

Pressure rating:	2500 kPa / 360 psi
Temperature rating, media:	-20°C to +130°C / -4°F to +266°F
Material:	
- Body:	Forged brass CW617N (tonval brass) or DZR brass CW602N CuZn36Pb2AS ("Enkotal®")
- Balls:	Chemically nickel plated brass
- Ball seals:	PTFE (reinforced Teflon)
- O-rings:	EPDM
End connections:	Fixed: 20mm male ISO suitable for DN15 EuroCone according to EN215, Annex A, Series S Multiple union end connections available

## DIMENSIONS AND WEIGHTS (NOMINAL) (measured in mm unless noted)

Model no.	Size D	W	L	A	End connections C <sup>1</sup>					W2 <sup>2</sup>	Weight (kgs.) (w/o end conn.)	
					Size	ISO female	ISO male	Compression	Press			Universal
F3895.X.XX.XX.I.X.X.X	G3/4"	84	62.5	40	15	32.7	29.0	9.4	35.6	4.1	11.3	0.5
					18	n/a	n/a					

Note 1: Add end connection length to body length.  
 Note 2: Add side-option width to body width (per side-option).

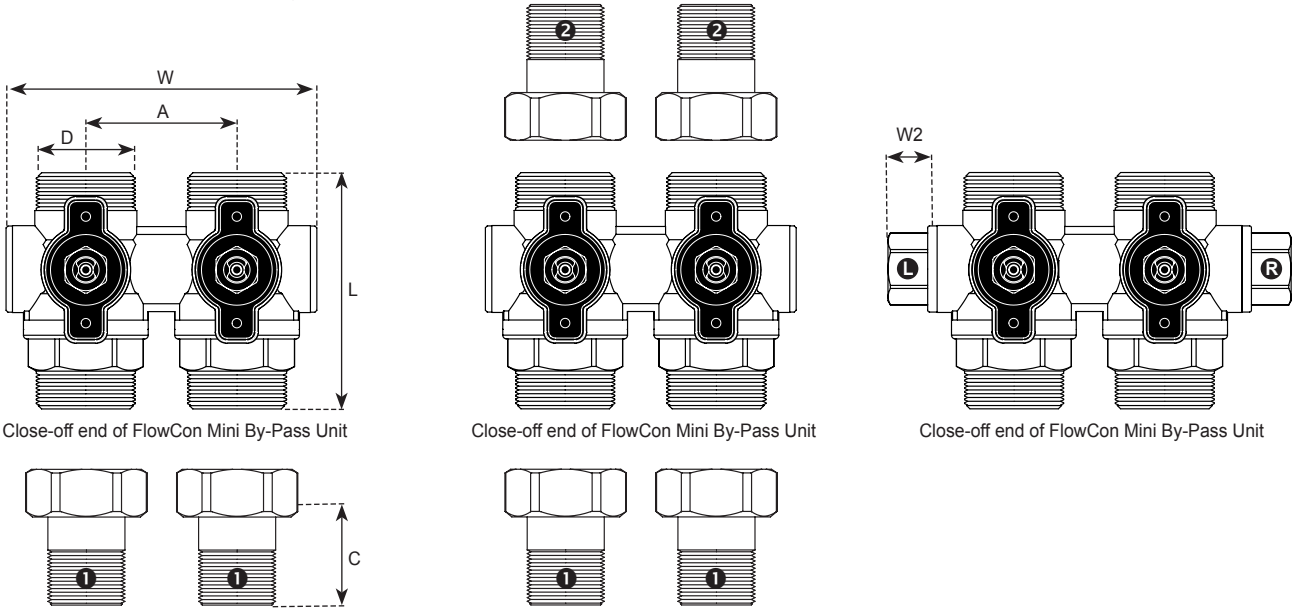

## MODEL NUMBER SELECTION

**F3895 . . . . . I . . . . .**

Insert by-pass size, fixed end:  
**0**=20mm male (ISO) suitable for DN15 EuroCone, no union end connections  
**2**=20mm male (ISO) suitable for DN15 EuroCone, two union end connections  
**4**=four union end connections

Insert connection size and type, union end<sup>3</sup>:  
**00**=no union end connection

Body size	Female threaded - for ISO male threaded pipes	Male threaded - for ISO female threaded pipes	Compression - for copper or soft steel pipes	Press <sup>4</sup> - for (stainless) steel pipes	Universal flat seal - for flat ends with unions
EuroCone end	<b>AG</b> =15mm=1/2"	<b>CG</b> =15mm=1/2" <b>CU</b> =20mm=3/4"	<b>HG</b> =15mm <b>HR</b> =18mm	<b>FG</b> =15mm <b>FR</b> =18mm	<b>EX</b> =one-size

Insert connection standard:  
**I**=ISO (standard)

Insert handle type:  
**0**=normal handles, no extensions (standard)  
**E**=handles with 4" handle extensions<sup>5</sup>

Insert side-option:  
**0**=blind (standard)  
**R**=1/4" ISO female threaded in right-hand side  
**L**=1/4" ISO female threaded in left-hand side  
**B**=1/4" ISO female threaded in both sides

Insert requirement to unit:  
**0**=not assembled  
**1**=assembled  
**2**=assembled and pressure tested

Insert valve body material:  
 Leave it **blank** for standard body material  
**D**=DZR brass

Example: F3895.2.CG.00.I.0.0.1 = FlowCon Mini By-Pass unit, two 20mm ISO male fixed ends suitable for DN15 EuroCone and two 15mm ISO male union ends, no handle extensions, no side-option, assembled.

Note 3: Other end connections and sizes available upon request.  
 Note 4: Extra width compared to standard option.  
 Note 5: When handle extensions are used, valves with actuators cannot be fitted in-line with handles, but must be tilted.

## APPLICATION EXAMPLE

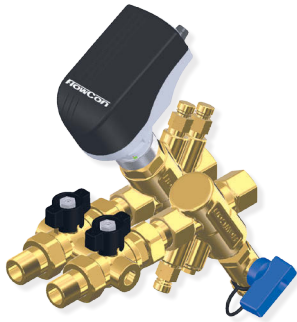

FlowCon Mini By-Pass unit with FlowCon Green

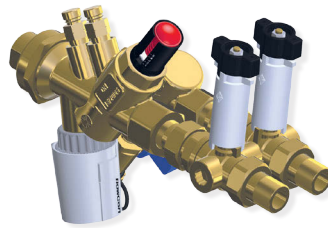

FlowCon Mini By-Pass unit with FlowCon EVC

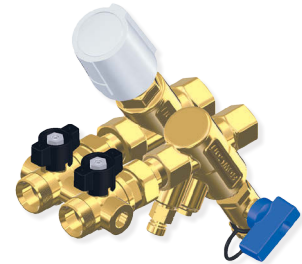

FlowCon Mini By-Pass unit with FlowCon EVS

### FlowCon Mini By-Pass unit with FlowCon Green

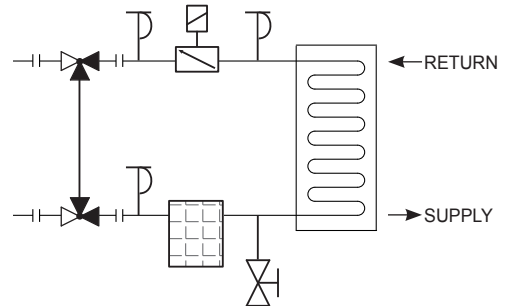
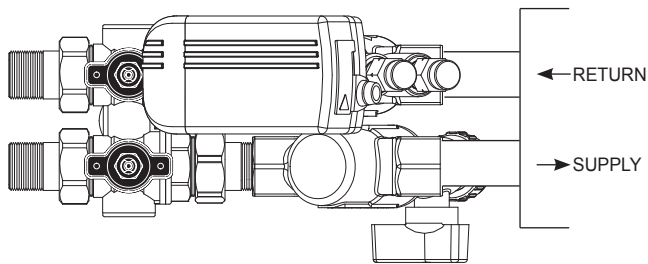

### FlowCon Mini By-Pass unit with FlowCon EVC

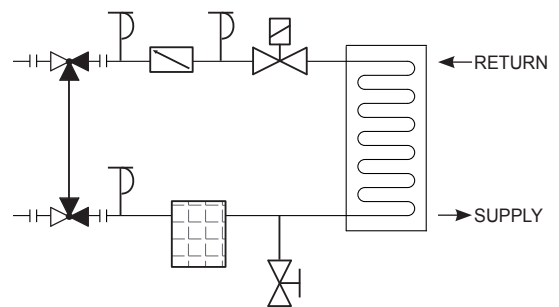
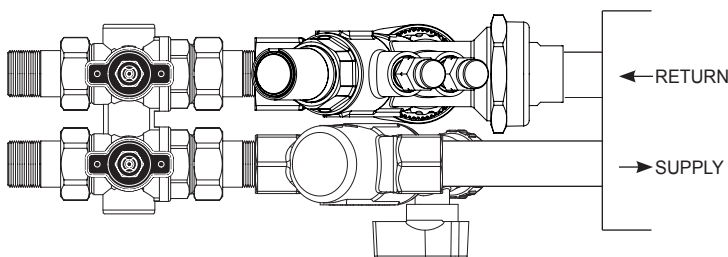

### FlowCon Mini By-Pass unit with FlowCon EVS

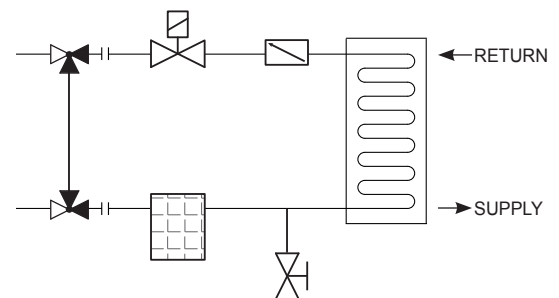
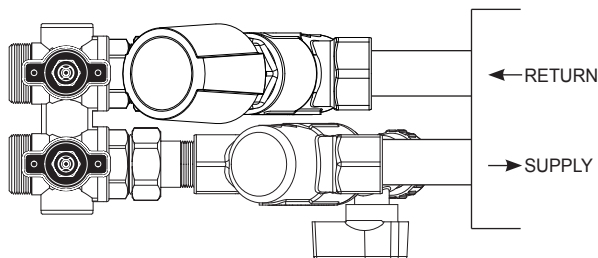

## UPDATES

For latest updates please contact FlowCon International or go to [www.flowcon.com](http://www.flowcon.com)

FlowCon International can accept no responsibility for possible errors in any printed material. All rights reserved.

# FlowCon By-Pass Unit

## 3 Way By-Pass Unit



### SPECIFICATIONS

Pressure rating:	2500 kPa / 360 psi
Temperature rating, media:	-20°C to +120°C / -4°F to +248°F
Material:	
- Body:	Forged brass ASTM CuZn40Pb2
- Ball valves:	Chemically nickel plated brass balls
- Union end connections:	Brass alloy ISO
- O-rings:	EPDM (70 shore)
End connections:	Fixed end (ISO): 2 x 1/2" or 2 x 3/4" Union end (ISO/NPT): 2 x (to match above) or 4 x FlowCon standard: 1/2" / 3/4" / 1" male or 1/2" or 3/4" female

## DIMENSIONS AND WEIGHTS (NOMINAL) (measured in mm unless noted)

Model no.	Size D	L	H	A	End connections C <sup>1</sup>				Weight (kgs.) (w/o end conn.)
					Size	ISO female	ISO male	Sweat	
F3890.1.M.X.H.H.X.X	15	122	106,8	80,2	15	22	25	20	1.1
F3890.2.M.X.I.I.X.X	20	122	104,8	80,2	20	22	25	20	1.1
					25	N/A	39	22	1.1
F3890.4.M.X.X.X.X.X	-	122	114,8	80,2	15	22	25	20	1.2
					20	22	25	20	1.2
					25	N/A	39	22	1.2

Note 1: Add end connection length to body length.

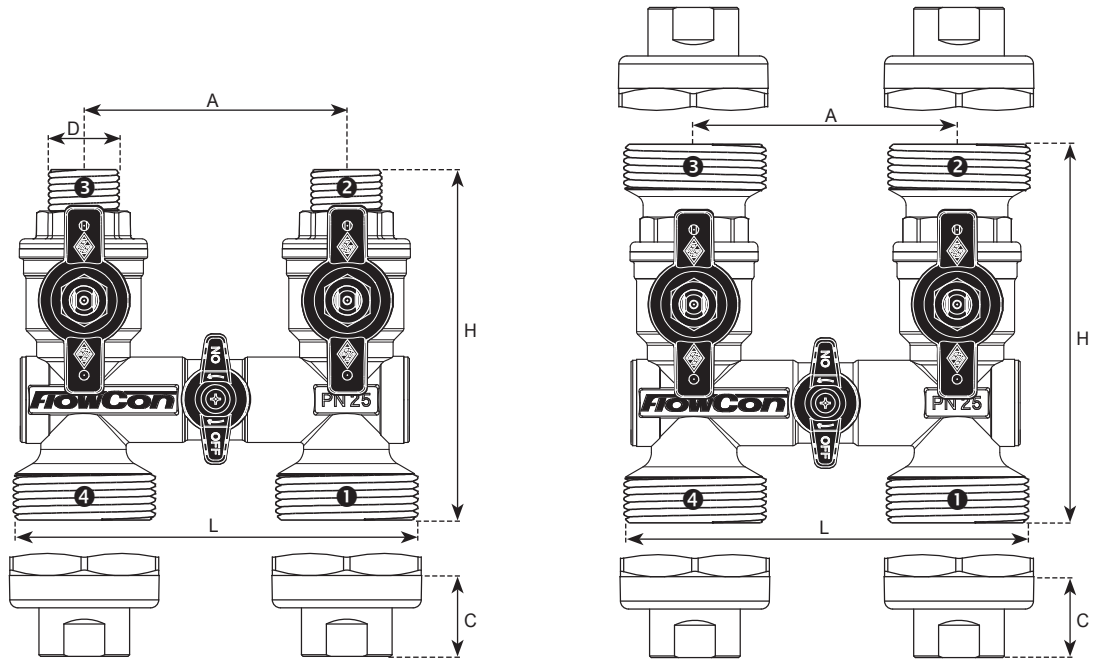

## MODEL NUMBER SELECTION

**F3890** . . . . . **M** . . . . .

Insert by-pass size, fixed end:  
**1**=15mm (ISO)   **2**=20mm (ISO)   **4**=four union ends connection

Insert connection type, fixed end:  
**M**=male

Insert connection size and type, union end:

Body size	Female threaded	Male treaded	Sweat
Union end 15-25mm, 1/2"-1"	<b>E</b> =15mm=1/2" <b>F</b> =20mm=3/4"	<b>H</b> =15mm=1/2" <b>I</b> =20mm=3/4" <b>J</b> =25mm=1"	<b>K</b> =15mm <b>L</b> =18mm <b>M</b> =22mm

Insert connection standard:  
**I**=ISO (standard)   **N**=NPT (not available for fixed ends)

**0**=not assembled  
**1**=assembled  
**2**=assembled and pressure tested

Example: F3890.1.M.H.H.H.H.I.0=By-pass unit, fixed end 15mm ISO male and union end 15mm ISO male, not assembled.

# APPLICATION EXAMPLE

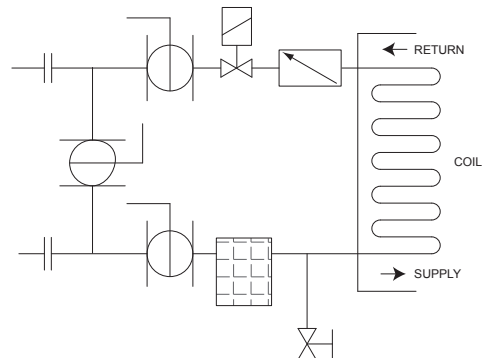
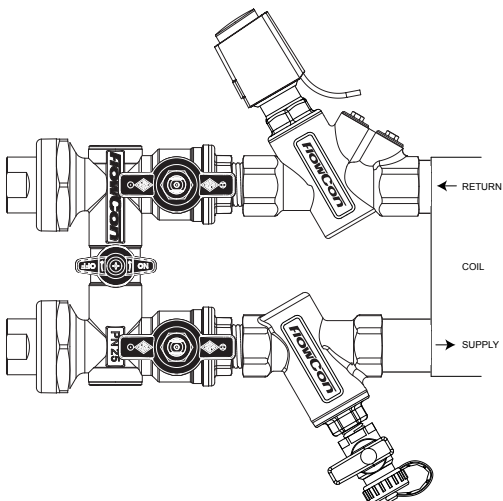
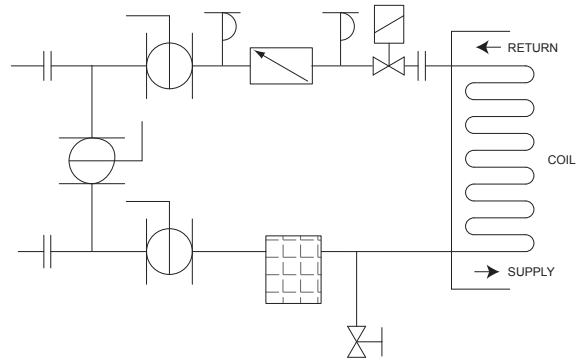
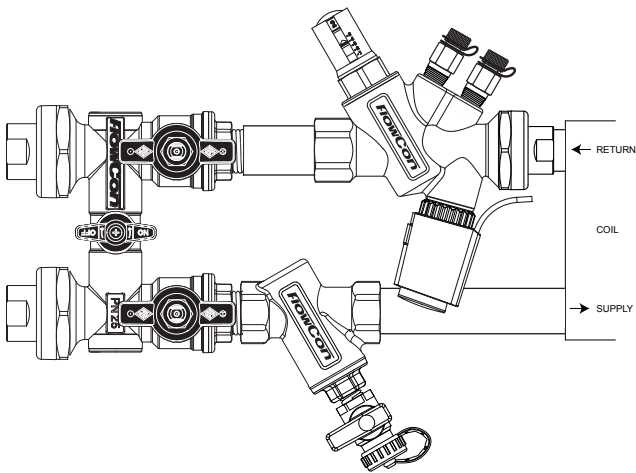
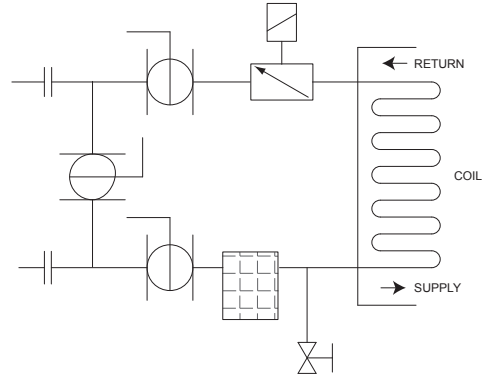
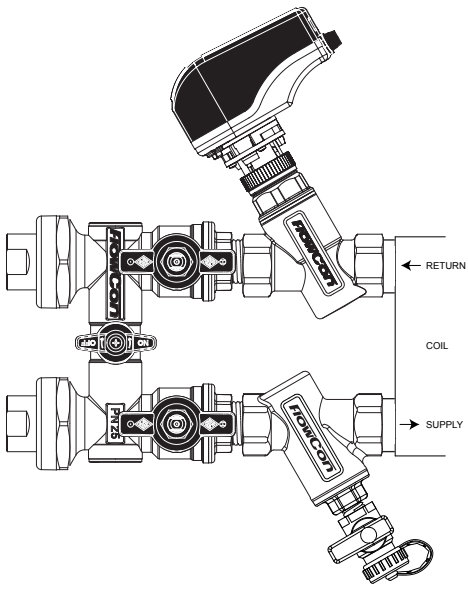

## UPDATES

**For latest updates please see [www.flowcon.com](http://www.flowcon.com)**

FlowCon International can accept no responsibility for possible errors in any printed material.  
All rights reserved.

# FlowCon Strainer 15-40mm

## Strainer Valve



### SPECIFICATIONS

Pressure rating: 2500 kPa / 360 psi  
Temperature rating, media: -20°C to +120°C / -4°F to +248°F  
Material:  
- Strainer: 250 $\mu$  (=60 mesh) stainless steel

#### **Valve:**

Material:  
- Body: Forged brass ASTM CuZn40Pb2  
- Ball valve: ABS: Chemically nickel plated brass ball  
End Connections: A: Female ISO or NPT  
AB: Female ISO or NPT  
ABS: Union end connections in brass alloy ISO or NPT

## DIMENSIONS AND WEIGHTS (NOMINAL) (measured in mm unless noted)

Valve model	Valve size	Strainer size	L	H1	H2	End connections C <sup>1</sup>			Weight <sup>2</sup> (kgs.) w/o end conn.
						ISO female	ISO male	Sweat	
A	15	20	80	31	79	-	-	-	0.48
	20								0.45
	25								0.49
AB	15	20	82	31	79	-	-	-	0.47
	20		94						0.53
	25		102						0.59
	25	40	82	47	104	-	-	-	1.90
	32		94						1.70
ABS1	15	20	122	33	79	22	24	20	0.75
	20					22	25	20	
	25					-	39	22	
ABS2	25	40	122	42	104	35	40	34	2.10
	32					33	40	34	
	40					33	42	-	

Note 1: Add end connection length to body length.

Note 2: Weight of valvebody with blind cap and blind plugs (without union end connections).

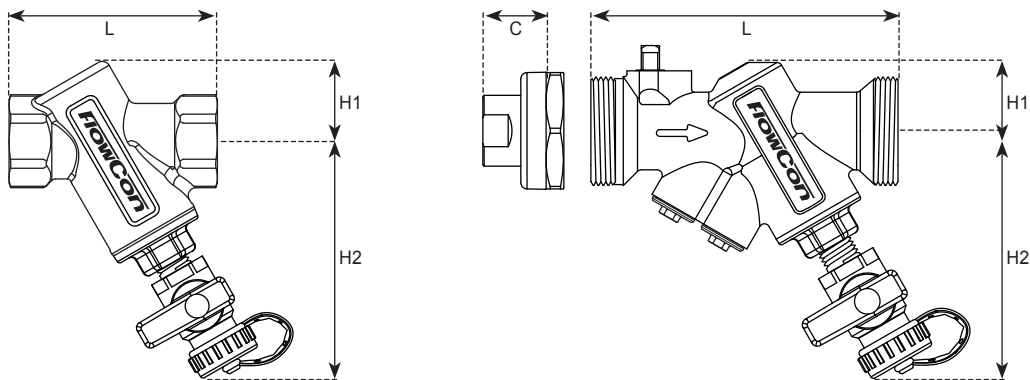

## MODEL NUMBER SELECTION

Insert type of cap:

**0**=No cap **1**=Cap **2**=Cap and Blowdown

Insert type of body:

20mm Strainer: **01**=AB15 **02**=AB20 **03**=ABS1 **04**=A15 **05**=A20 **06**=A25 **07**=AB25  
40mm Strainer: **15**=ABS2 **21**=AB25 **22**=AB32

Insert p/t plug requirements:

Leave it **blank** if no p/t plugs are required **B**=pressure/temperature plugs **P**=taps plugged

Insert inlet x outlet union end connections - leave it **blank** if A- or AB-body or no end connections required:

Body size	Female threaded	Male threaded	Sweat
Union end 15-25mm, 1/2"-1"	<b>E</b> = 15mm=1/2" <b>F</b> = 20mm=3/4"	<b>H</b> = 15mm=1/2" <b>I</b> = 20mm=3/4" <b>J</b> = 25mm=1"	<b>K</b> = 15mm <b>L</b> = 18mm <b>M</b> = 22mm
Union end 25-40mm, 1"-1 1/2"	<b>G</b> = 25mm=1" <b>P</b> = 32mm=1 1/4" <b>Q</b> = 40mm=1 1/2"	<b>J</b> = 25mm=1" <b>S</b> = 32mm=1 1/4" <b>T</b> = 40mm=1 1/2"	<b>N</b> = 28mm <b>W</b> = 35mm

Insert connection standard:

**I**=ISO **N**=NPT

Example: S.1.01.P.I=Strainer in AB 15mm ISO female threaded body with plugs.

## ACCESSORIES

- Strainer, mesh 60: ACC609002 (DN15/20/25), ACC609003 (DN25/32/40)
- Blind cap: ACC0080 (DN15/20/25), ACC0081 (DN25/32/40) (cap for flushing out the system)
- Blow-down cap: ACC0082 (DN15/20/25), ACC0083 (DN25/32/40) (cap for applying drain valve)
- Drain valve: ACC913302 (1/4").

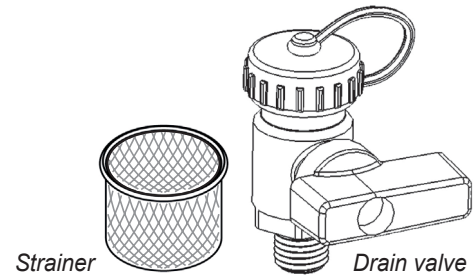

## GENERAL SPECIFICATIONS

### 1. STRAINER - FLOWCON A

- 1.1. Contractor shall install strainers where indicated in drawings.
- 1.2. Valve shall consist of strainer, mesh 60.

### 2. VALVE HOUSING

#### 2.a. **FlowCon A**

- 2.a.1. Valve housing shall consist of forged brass ASTM CuZn40Pb2, rated at no less than 2500 kPa static pressure and +120°C.
- 2.a.2. Valve housing shall be permanently marked to show direction of flow.
- 2.a.3. Housing shall be configured for strainer unit accessibility.
- 2.a.4. Drain valve shall be available for all valve sizes.

OR....

#### 2.b. **FlowCon AB**

- 2.b.1. Valve housing shall consist of forged brass ASTM CuZn40Pb2, rated at no less than 2500 kPa static pressure and +120°C.
- 2.b.2. Valve housing shall be permanently marked to show direction of flow.
- 2.b.3. Optional pressure/temperature test plugs for verifying performance shall be available for all valve sizes.
- 2.b.4. Housing shall be configured for strainer unit accessibility.
- 2.b.5. Drain valve shall be available for all valve sizes.

OR....

#### 2.c. **FlowCon ABS**

- 2.c.1. Valve housing shall consist of forged brass ASTM CuZn40Pb2, rated at no less than 2500 kPa static pressure and +120°C.
- 2.c.2. Valve housing shall be permanently marked to show direction of flow.
- 2.c.3. Valve housing shall be double union end constructed with a range of pipe connections available for the appropriate pipe size.
- 2.c.4. Valve ball shall consist of chemically nickel plated brass (ASTM CuZn40Pb2).
- 2.c.5. Optional pressure/temperature test plugs for verifying performance shall be available for all valve sizes.
- 2.c.6. Housing shall be configured for strainer unit accessibility.
- 2.c.7. Drain valve shall be available for all valve sizes.

## UPDATES

**For latest updates please see [www.flowcon.com](http://www.flowcon.com)**

FlowCon International can accept no responsibility for possible errors in any printed material.  
All rights reserved.

## FlowCon FAC6HP

FlowCon Commissioning Meter



### SPECIFICATIONS

Pressure rating:	2000 kPa / 209 psi
Temperature rating, media:	1°C to +95°C / 33.8°F to +203°F
Temperature rating, ambient when in operation:	1°C to +44°C / 33.8°F to +111°F
IP rating:	IP54
Maximum operational $\Delta P$ :	1000 kPaD / 145 psid
Measurement range:	0.5-600 kPaD / 0.07-87 psid.

## DIMENSIONS AND WEIGHTS (NOMINAL) (measured in mm unless noted)

Model no.	Description	L1	L2	H1	H2	B (depth)	Weight (kgs.) with and without tubes and needles
FAC6HP	without rubber protection boot	85	117	159	189	31	1.25 / 0.46
	with rubber protection boot	98	123	173	203	42	1.41 / 0.62

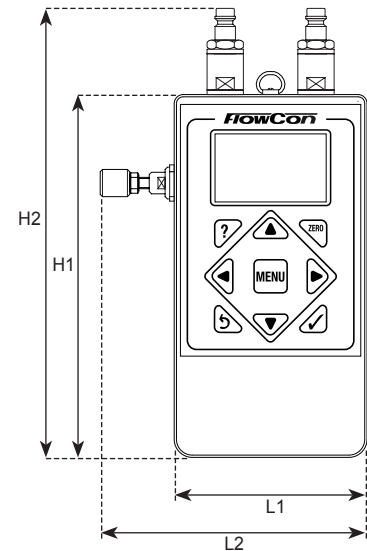

## MODEL NUMBER SELECTION

FlowCon Commissioning Meter \_\_\_\_\_

**FAC6HP**

## FUNCTIONS

Battery:	9V 6LR61
Connection to PC requires optional software (see the accessories):	USB Mini
Flow characteristics for:	
FlowCon Composite Insert series (20-40mm)	
FlowCon E-JUST Insert series (20-50mm)	
FlowCon Stainless Steel Insert series (20-80mm)	
FlowCon SH series (15-150mm)	
FlowCon Green Insert series (20-40mm)	<b>Note:</b> Measurement only to be done either without actuator or with actuator fully open
FlowCon SME Insert series (20-40mm)	
FlowCon SM series (15-150mm)	<b>Note:</b> Measurement only to be done either without actuator or with actuator fully open
Measurement range:	0.5-600 kPaD
Measurement accuracy:	± 0.2 kPaD within 0.5-20 kPaD range ± 1.0% of reading within 20-600 kPaD range
Hysteresis:	± 1.0% of reading within 20-600 kPaD range
Storage:	Default 100 locations. Up to 2000 locations with optional software (see the accessories options)
DP units:	Pa, kPa, bar, m H <sub>2</sub> O, mm H <sub>2</sub> O, cm H <sub>2</sub> O, psi, feet H <sub>2</sub> O, inches H <sub>2</sub> O
Flow units:	l/s, l/min, l/h, (imperial) gpm, (US) gpm.

## ACCESSORIES

- Set of 1m tubes with snap connectors: ACC6000
- Set of 3.3mm p/t needle for snap connectors, straight, incl. protection pipe (to be removed before use): ACC6001
- Set of 3.3mm p/t needle for snap connectors, angle, incl. protection pipe (to be removed before use): ACC6002
- Set of 3.3mm p/t needle for snap connectors, extra long and straight, incl. protection pipe (to be removed before use): ACC6003
- Set of 3.3mm p/t needle for snap connectors, extra long and angle, incl. protection pipe (to be removed before use): ACC6004
- Software for calculations of flow in wafers and/or administration of larger projects: ACC6010.

## GENERAL DESCRIPTION

The FlowCon FAC6HP is an electronic manometer programmed to carry out differential pressure measurements on FlowCon's dynamic balancing valves and other balancing valves. The state-of-the-art software and complete database of FlowCon's dynamic balancing valves allows direct reading of differential pressure and flow. The nine button design allows simple navigation of the menu system with all parameters visible on screen.

## CARRY CASE

The commissioning meter is supplied in a carry case with foam inlay for protection of the items inside. The carry case contains:

- FAC6HP commissioning meter including fittings for snap connectors and protection caps for fittings
- Set of 1m tubes with snap connectors (ACC6000)
- Set of 3.3mm p/t needles for snap connectors, angle, incl. protection pipe (to be removed before use) (ACC6002)
- Set of 3.3mm p/t needles for snap connectors, straight, incl. protection pipe (to be removed before use) (ACC6001)
- Extra 9V 6LR61 battery
- FlowCon adjustment key
- 6-in-1 screw driver (for PH 1-2-3 and PZ 1-2-3)
- Hexagon (allen) keys (sizes 3.0, 4.0, 5.0, 6.0 and 8.0mm)
- Mechseal key
- Extra protection caps for commissioning meter fittings
- Key hanger for hanging commissioning meter from pipes etc.

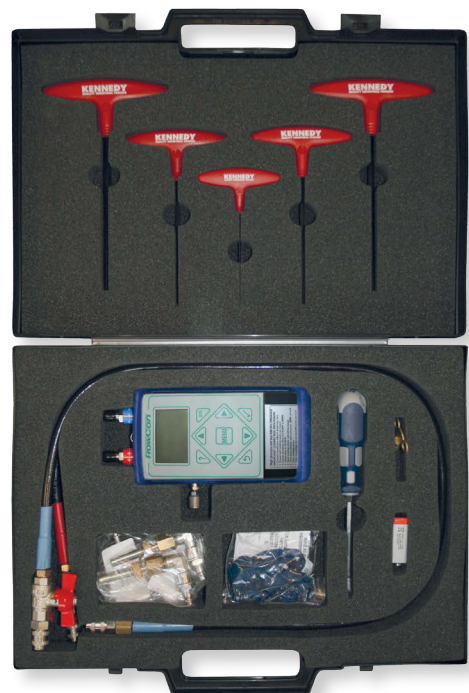

## APPLICATION EXAMPLE

FlowCon commissioning meter connected to a FlowCon AB-valve with pressure/temperature plugs and FlowCon Green insert, without actuator.

**Note: Measurement only to be done either without actuator or with actuator fully open.**

FlowCon commissioning meter display:

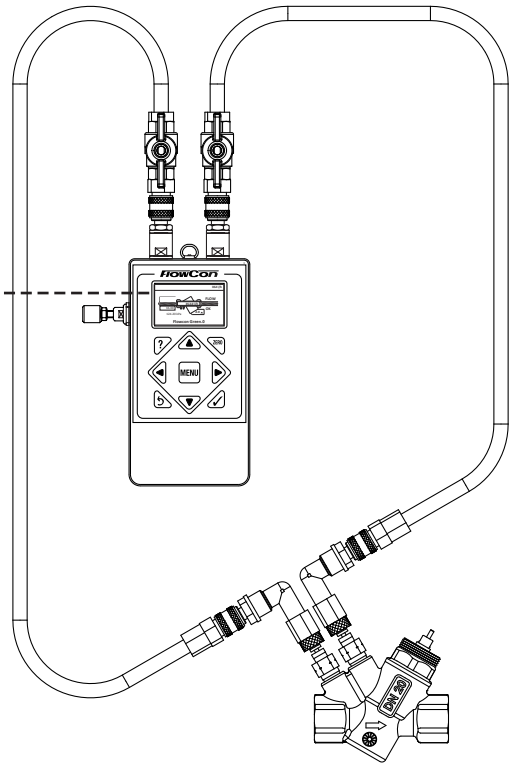
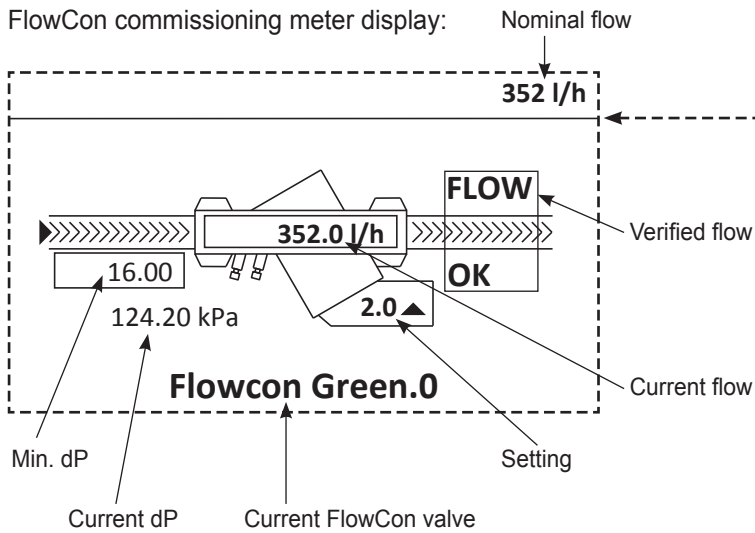

## UPDATES

For latest updates please see [www.flowcon.com](http://www.flowcon.com)

FlowCon International can accept no responsibility for possible errors in any printed material. All rights reserved.

# FlowCon Insulation Shells

*Insulation shells for FlowCon valves*



## SPECIFICATIONS

Temperature rating:	-55°C to +105°C / -67°F to +221°F
Material:	EPP (polypropylene foam)
Resistant to:	Water, sea water, glycol, silicone grease, alcohol (ethanol), soaps, deterative solutions (10% Extran MA01), mild acids (10% Nitric acid, 10% Sulfuric acid, 10% Hydrochloric acid).

## DIMENSIONS AND WEIGHTS (NOMINAL) (measured in mm unless noted)

Model no.	Fits	L1	L2	W	H1	H2	Weight (kgs.)
IF3890	F3890.4	120	-	170	63	45	0.06
IA	A 15-25 with: - E-JUST <sup>1</sup> - Composite <sup>1</sup> - Stainless steel insert in adaptor <sup>1</sup> - Strainer - Strainer w. drain valve	177	165	79	115	45	0.04
IAB	AB 15-25 small with: - E-JUST <sup>1</sup> - Composite <sup>1</sup> - Stainless steel insert in adaptor <sup>1</sup> - Strainer - Strainer w. drain valve	177	165	79	115	45	0.04
IEVC	EVC 15-20 with: - E-JUST - Composite	168	155	79	85	45	0.04
IEVS	A 15-25 with EVS AB 15-25 small with EVS	177	165	79	85	45	0.03
IGreen	A 15-25 with Green.0/1 AB 15-25 small with Green.0/1 ABV 15-25 small with Green.0/1 <sup>1</sup>	177	165	79	85	50	0.03
ITJUST	A 15-25 with T-JUST AB 15-25 small with T-JUST ABV 15-25 small with T-JUST	177	165	79	85	50	0.03

Note 1: Not applicable if the insulation shell is combined with IF3890.

**Insulation Shell - FlowCon IA / IAB**

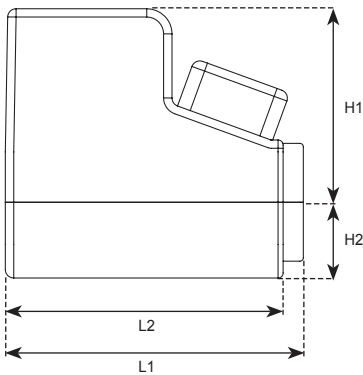

**Insulation Shell - FlowCon IEVC**

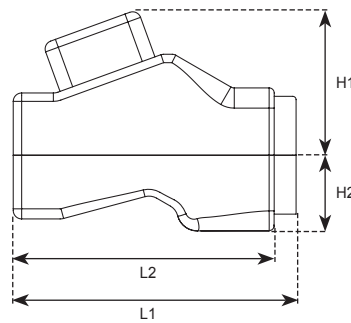

**Insulation Shell - FlowCon IEVS**

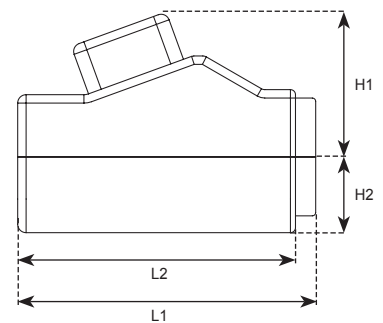

**Ins. Shell - FlowCon IGreen / ITJUST**

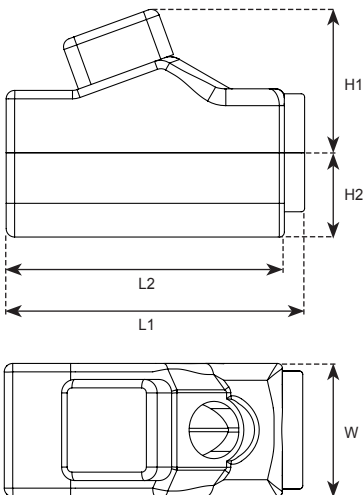

**Insulation Shell - FlowCon IF3890**

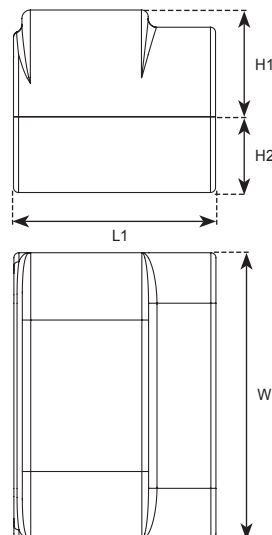

## MODEL NUMBER SELECTION

Insert type of valve/valve body:

**F3890**= for By-Pass unit with 4 unions

**A**= for A housings with E-JUST<sup>2</sup> / Composite<sup>2</sup> / Stainless steel insert in adaptor<sup>2</sup> / Strainer<sup>2</sup> / Strainer w. drain valve

**AB**= for AB housings DN15-25 small with E-JUST<sup>2</sup> / Composite<sup>2</sup> / Stainless steel insert in adaptor<sup>2</sup> / Strainer / Strainer w. drain valve

**EVC**= for EVC housings with E-JUST (alternatively Composite / Stainless steel insert in adaptor, but cap not covered)<sup>3</sup>

**EVS**= for A / AB housings DN15-25 small with EVS and Stainless steel insert<sup>3</sup>

**Green**= for A / AB / ABV<sup>2</sup> housings DN15-25 small with Green.0/.1<sup>3</sup>

**TJUST**= for A / AB / ABV housings DN15-25 small with T-JUST<sup>3</sup>

Note 2: Not to be combined with IF3890.

Note 3: Actuator will be outside the shell.

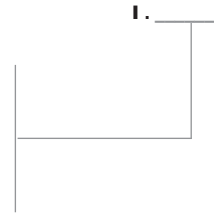

## ACCESSORIES

Spare part p/t plug cap: ACCIPT.

## GENERAL DESCRIPTION

The insulation shells are temperature insulation for FlowCon valves in environments with temperatures very different from the media temperatures in the valves. The insulation shells are easily fitted and removed (if necessary) due to the soft snap function of the foam. All insulation shells for valve housings are also included with the accessory part ACCIPT (for easy access to the optional p/t plugs).

The insulation shells IA (for A-body with strainer / strainer with drain valve), IAB (for AB-body with strainer / strainer with drain valve), IEVC (for EVC-body), IEVS (for EVS-insert w. either A or AB-body) and IGreen (for Green inserts w. either A or AB-body) can be combined with IF3890 (for By-Pass unit) so that there is an overlap between the two parts which will affect the total length.

## APPLICATION EXAMPLE

③ IF3890 on By-Pass valve with 4 unions.

- ① IA on A 20mm housing with strainer and drain valve.  
Note: IA/IAB can only be fitted on supply side when used together with IF3890.

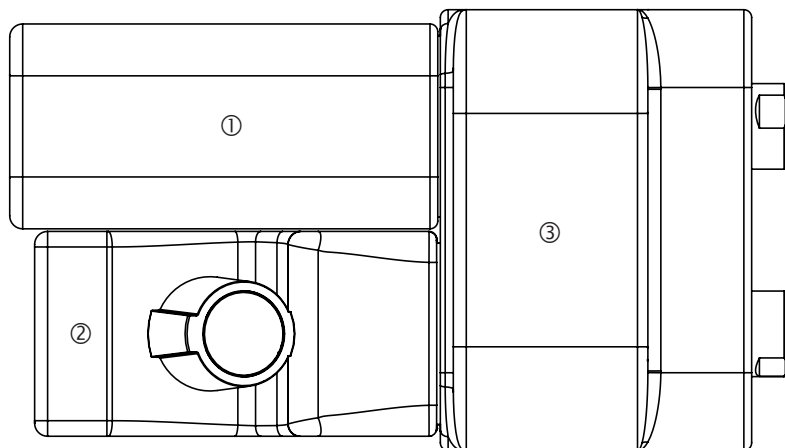

② IEVC on EVC 20mm housing with E-JUST and EV actuator.

## UPDATES

For latest updates please see [www.flowcon.com](http://www.flowcon.com)

FlowCon International can accept no responsibility for possible errors in any printed material.  
All rights reserved.